

SBC84600

3.5" HDD Form Factor

**All-in-One
CPU Board**

User's Manual

Disclaimers

The information in this manual has been carefully checked and is believed to be accurate. AXIOMTEK Co., Ltd. assumes no responsibility for any infringements of patents or other rights of third parties which may result from its use.

AXIOMTEK assumes no responsibility for any inaccuracies that may be contained in this document. AXIOMTEK makes no commitment to update or to keep current the information contained in this manual.

AXIOMTEK reserves the right to make improvements to this document and/or product at any time and without notice.

No part of this document may be reproduced, stored in a retrieval system, or transmitted, in any form or by any means, electronic, mechanical, photocopying, recording, or otherwise, without the prior written permission of AXIOMTEK Co., Ltd.

©Copyright 2005 by AXIOMTEK Co., Ltd.

All rights reserved.

January 2005, Version A6

Printed in Taaiwn

ESD Precautions

Integrated circuits on computer boards are sensitive to static electricity. To avoid damaging chips from electrostatic discharge, observe the following precautions:

- Do not remove boards or integrated circuits from their anti-static packaging until you are ready to install them.
- Before handling a board or integrated circuit, touch an unpainted portion of the system unit chassis for a few seconds. This helps to discharge any static electricity on your body.
- Wear a wrist-grounding strap, available from most electronic component stores, when handling boards and components.

Trademarks Acknowledgments

AXIOMTEK is a trademark of AXIOMTEK Co., Ltd.

IBM is a registered trademark of International Business Machines Corporation.

MS-DOS, and Windows 98/NT/2000/XP are trademarks of Microsoft Corporation.

Award is a trademark of Award Software, Inc.

IBM, PC/AT, PS/2, VGA are trademarks of International Business Machines Corporation.

VIA C3 and other trademarks of VIA Technology.

Realtek RTL-8139C are registered trademark of Realtek Semiconductor Corporation.

Other brand names and trademarks are the properties and registered brands of their respective owners.

-This page does not contain any information.

Table of Contents

Chapter 1 Introduction.....	1
1.1 General Description.....	1
1.2 Specifications.....	2
1.3 Models.....	3
Chapter 2 Installation.....	5
2.1 Installation Steps.....	5
2.2 Peripherals for a Minimum System.....	5
2.3 Installation of SBC84600 into a Chassis.....	6
Chapter 3 Jumpers and Connectors.....	9
3.1 Jumpers and Connectors Layout.....	9
3.2 Jumpers and Connectors Dimensions.....	10
3.3 Jumper Settings.....	11
3.3.1 Watchdog Timer Trigger Mode Setting: JP1.....	12
3.3.2 Power Selection of Flat Panel Connector (VDDM of LCD1 and LCD2): JP2.....	12
3.3.3 CMOS Clear Jumper: JP3.....	12
3.3.4 COM2 RS232/422/485 Settings: JP4, JP5, JP6.....	13
3.3.5 Power Supply Type Selection: JP7.....	13
3.3.6 COM2 Signal/+5V Selection: JP8.....	13
3.3.7 COM1 Signal/+5V Selection: JP9.....	14
3.3.8 COM4 Signal/+5V Selection: JP10.....	14
3.3.9 COM3 Signal/+5V Selection: JP11.....	14
3.3.10 Compact Flash Voltage Selection: JP12.....	14
3.4 Connectors.....	15
3.4.1 Enhanced IDE Interface Connector: CN1.....	16
3.4.2 Flat Panel Bezel Connector: CN3.....	17
3.4.3 VGA/Flat Panel Connector: VGA1, CN2, CN4.....	18
3.4.4 CPU Fan Connector: CN5.....	24
3.4.5 Parallel Port: CN7.....	25
3.4.6 Digital I/O Port (DIO1): CN8.....	26
3.4.7 ATX Power On /Off Button: CN9.....	27
3.4.8 Power Input Connector: CN10.....	28
3.4.9 IrDA Connector: CN11.....	28
3.4.10 AC97 Interface Link Connector: CN12.....	29
3.4.11 Keyboard and PS/2 Mouse Connectors: CN13.....	29

3.4.12 Composite Video Output: CN14, VIDEO1 (Optional Feature)	30
3.4.13 FDD Connector: CN15.....	30
3.4.14 USB Connectors: USB1 and USB2.....	31
3.4.15 Ethernet PJ-45 Connector: LAN1	31
3.4.16 PC/104 Connectors: J1 and J2.....	33
3.4.17 Serial Port Interface.....	34
3.4.18 Compact Flash Connector: CF1.....	35
Chapter 4 Hardware Description	39
4.1 Microprocessors	39
4.2 BIOS	39
4.3 Real Time Clock and CMOS RAM	39
4.4 System Memory	39
4.5 VGA Interface	40
4.6 Audio	40
4.6.1 Board Layout.....	41
4.7 I/O Port Address Map.....	43
4.8 Interrupt Controller	44
Chapter 5 Award BIOS Utility.....	45
5.1 BIOS Introduction	45
5.2 BIOS Setup	45
5.2.1 Standard CMOS Setup	47
5.2.2 Advanced BIOS Features	51
5.2.3 Advanced Chipset Features	56
5.2.4 Integrated Peripherals	59
5.2.5 Power Management Setup.....	62
5.2.6 PNP/PCI Configuration	64
5.2.7 PC Health Status	66
5.2.8 Frequency/Voltage Control	67
5.2.9 Load Fail-Safe Defaults	68
5.2.10 Load Optimized Defaults	69
5.2.11 Set Supervisor/User Password.....	70
5.2.12 Save & Exit Setup.....	71
5.2.13 Exit Without Saving	72
Appendix A Watchdog Timer.....	73

Chapter 1

Introduction

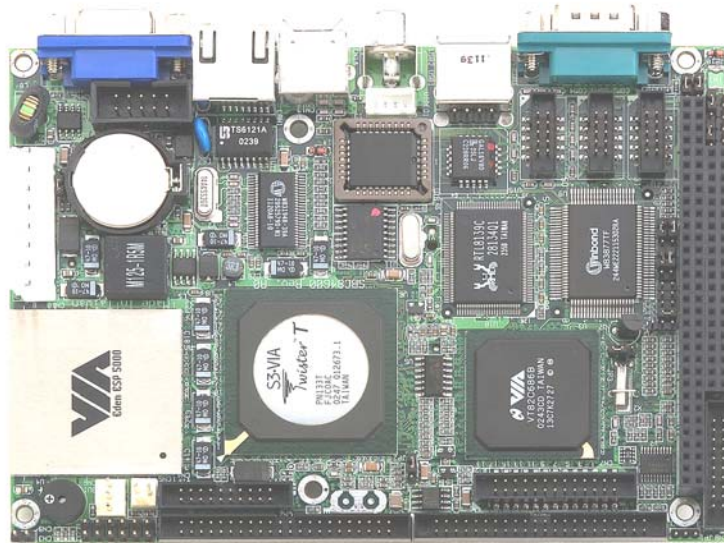

1.1 General Description

The **SBC84600** is a featured-pack CPU Board designed for industrial purpose. It provides reliable high performance and function-rich capability.

The onboard CPU incorporates the VIA VT8606 chipset and the VT82C686B with built-in AGP-4x VGA controller; the PC/104 bus is available for further expansions. Its 8-layer structure reduces signal noise and meets ACPI function with its built-in power management feature.

Designed for the professional embedded developers, this **SBC84600** is virtually an ultimate one-step solution to various applications. It provides fanless possibility for critical application environments with low power consumption design to improve system MTBF.

1.2 Specifications

- **Processor:**
 - VIA EDEN 400MHz, 667MHz, or C3 800MHz (C3 1GHz CPU or other frequency processors are manufacturer optional)
- **L2 Cache:**
 - Integrated in CPU
- **Chipset:**
 - VT8606 (Twister-T) + VT82C686B
- **System Memory:**
 - One 144-pin DIMM socket
 - Maximum up to 512MB SDRAM
- **BIOS:**
 - AWARD BIOS, Plug-and-Play 4Mbit Flash ROM with SmartView VGA BIOS Function and integrated Ethernet Novell RPL and Windows PXE Boot ROM functions
- **Watchdog Timer:**
 - Generates a system reset or NMI by jumper selectable
 - Software programmable time interval
 - 64 levels, 0.5~8/5~80/50~800/100~1600 seconds
- **Standard I/O:**
 - Four serial ports, including three RS-232 and one RS-232/422/485
 - One parallel port, SPP/EPP/ECP
 - One HDD Interface
 - One FDD Interface
 - One PS/2 Keyboard & Mouse Interface
 - One IrDA interface for wireless communication
- **USB Interface:** 2 USB ports with USB Spec. Rev. 1.1a compliant
- **Ethernet:**
 - Realtek 8139C PCI Bus 10/100M Base-T
 - Wake On LAN (via ATX power supply)
 - Onboard RJ-45 connector

- **Digital I/O:** 8-channel TTL/DTL compatible input and output
- **Board ID:** Dallas DS2401 Board unique ID support
- **Solid State Disk Interface:**
 - One CompactFlash Type II Socket
- **Expansion Slot:** one 16-bit pc/104 connector
- **AC97 Link:** AC97 Link interface for external audio Codec Kit (AX93102)
- **Drivers:**
 - VIA Chipset Driver
 - Ethernet Utility and Drivers
 - VGA Drivers

1.3 Models

- **SBC84600VE-400:** SBC84600 with Eden 400MHz CPU, CRT/LCD, Ethernet
- **SBC84600VE-667:** SBC84600 with Eden 667MHz CPU, CRT/LCD, Ethernet
- **SBC84600VE-800:** SBC84600 with C3 800MHz CPU, CRT/LCD, Ethernet
- **SBC84600VEA-400:** SBC84600 with Eden 400MHz CPU, CRT/LCD, Ethernet and Audio (with AX93102)
- **SBC84600VEA-667:** SBC84600 with Eden 667MHz CPU, CRT/LCD, Ethernet and Audio (with AX93102)
- **SBC84600VEA-800:** SBC84600 with C3 800MHz CPU, CRT/LCD, Ethernet and Audio (with AX93102)

This page does not contain any information.

Chapter 2

Installation

2.1 Installation Steps

Follow the steps listed below to install the **SBC84600** in the system.

1. Make sure the power is *OFF*.
2. Set the configuration jumpers according to the jumper settings in Chapter 3.
3. Connect the I/O cables and peripherals, i.e. floppy disk, hard disk, monitor, keyboard, power supply and etc. to the CPU board.

NOTE: *The color of pin one is usually red or blue, while others are gray.*

2.2 Peripherals for a Minimum System

The following is a list of typical peripherals required to build a minimum system:

- **AT or ATX Power supply**
- **IBM™ PS/2 keyboard And Mouse**
- **Display monitor**
- **Floppy or hard disk with MS-DOS or Flash Disk emulator**

2.3 Installation of SBC84600 into a Chassis

Please follow the steps below to install the SBC84600 onto a chassis:

1. Remove the pillar (a) from the SBC84600 as shown in Figure 1.

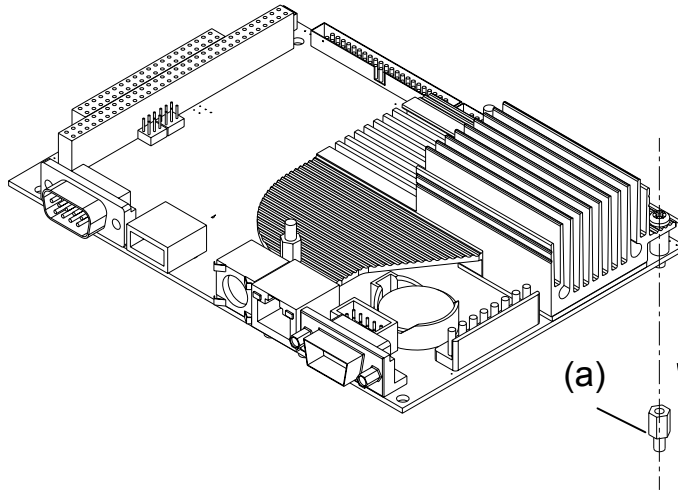

Figure 1.

2. Screw the pillar (a) removed from the SBC84600 and another three pillars (c), which have same height with the pillar (a), to the chassis as shown in the Figure 2.
3. Use the bolt (b) on the SBC84600 module to screw the module with the pillar (a) on the chassis.
4. Screw three proper bolts (d) to the other three pillars (c) to secure the board with the chassis.

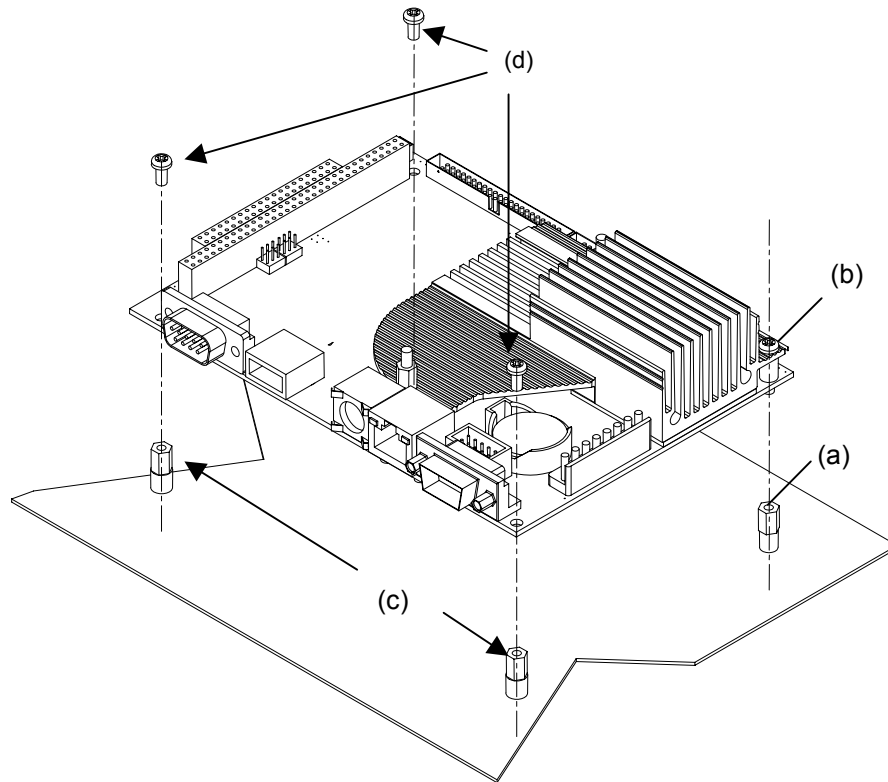

Figure 2.

5. If the Audio kit, AX93102, is used, plug the 10-pin female box-header of the AX93102 onto the 10-pin male box-header of the SBC84600 as shown on Figure 3.
6. Make sure the spacer support (e) fit into the hole (f) on the SBC84600.

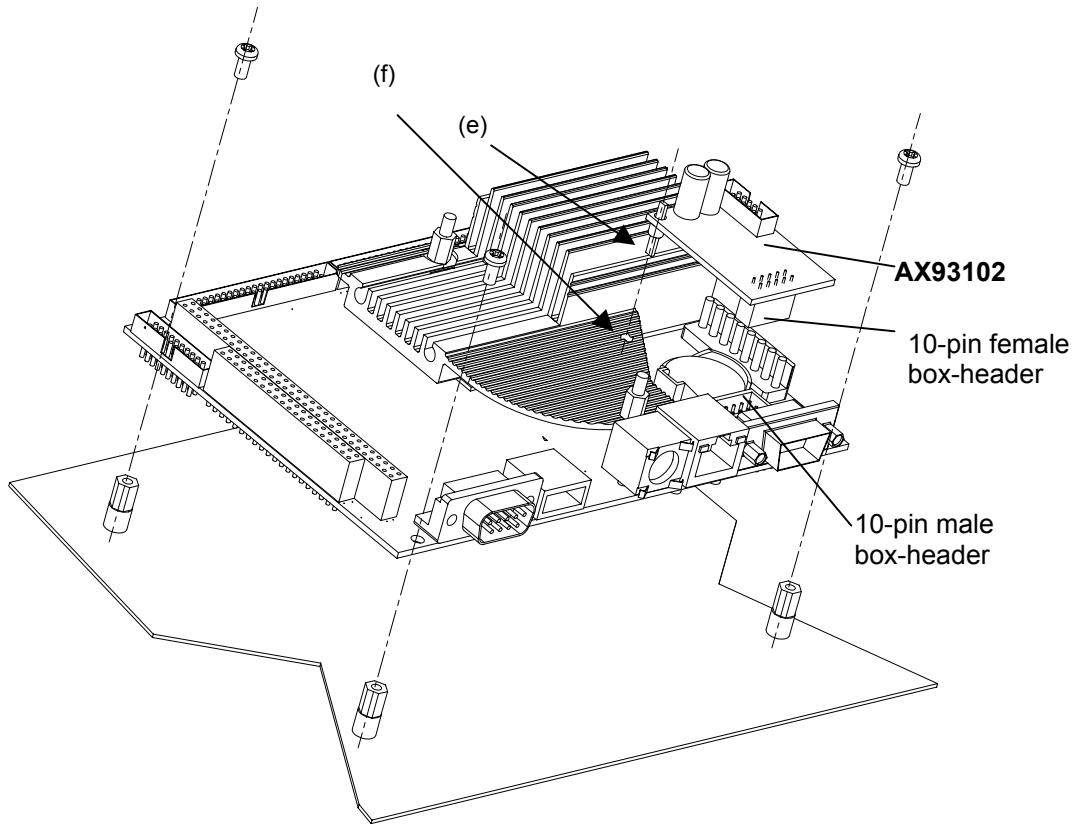
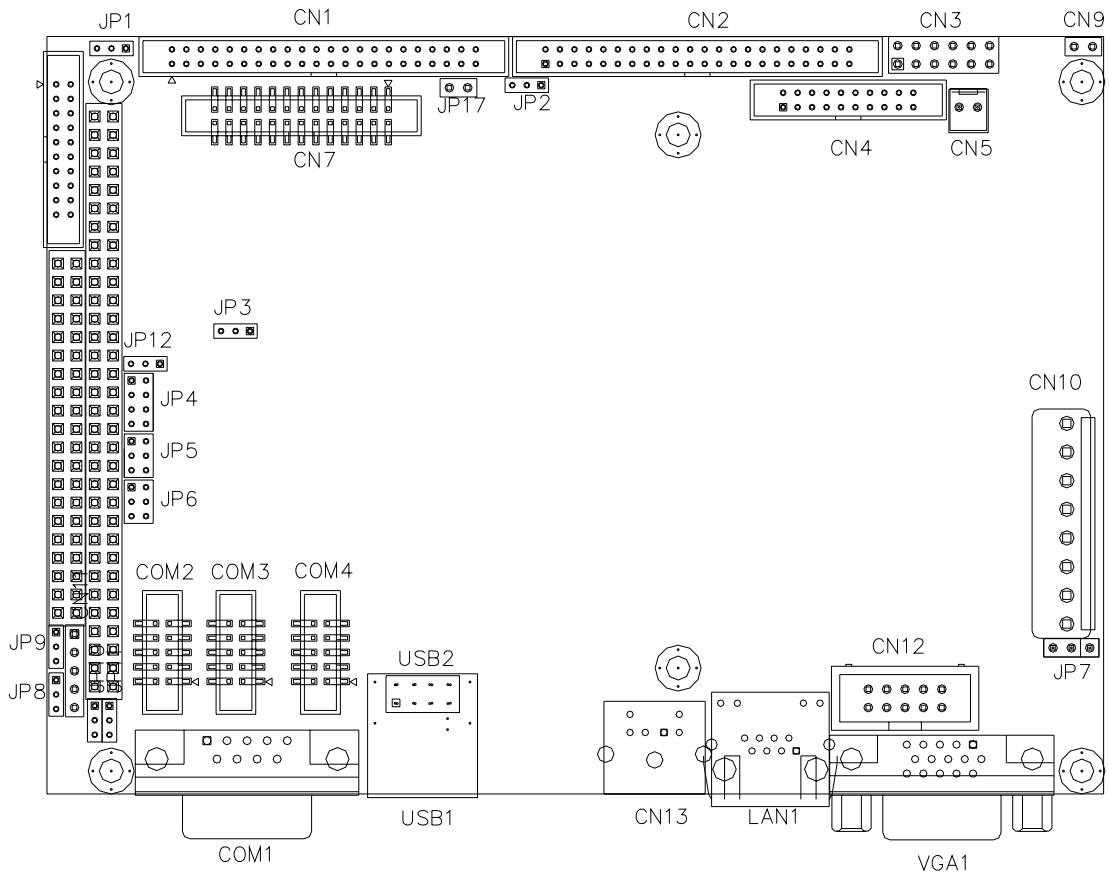

Figure 3

Chapter 3 Jumpers and Connectors

3.1 Jumpers and Connectors Layout



3.2 Jumpers and Connectors Dimensions

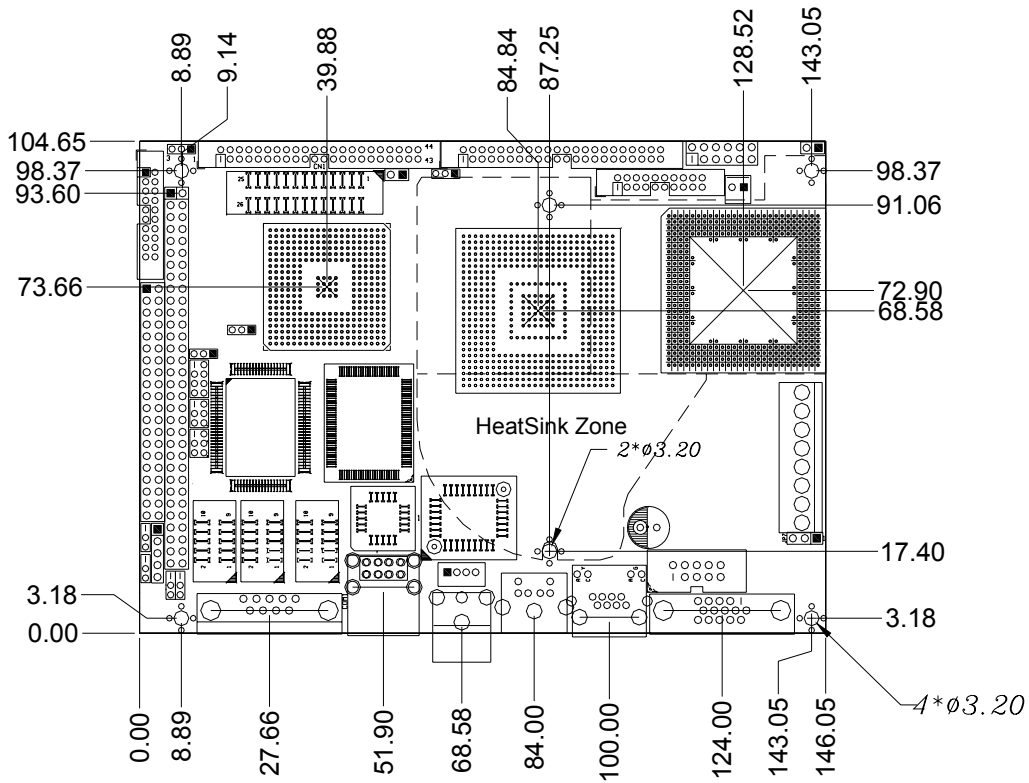

3.3 Jumper Settings

Making the proper jumper settings configure the **SBC84600** to match the needs of your application.

The following table shows the default jumper settings for the onboard devices.

Jumper	Default Setting	Jumper Setting
JP1	Watchdog Trigger Mode: Disabled	Open
JP2	Flat Panel Power Selection: VDDM at 5V	Short 1-2
JP3	Clear CMOS Setting: Normal	Short 1-2
JP4	COM2 Port Setting: RS-232	Short 1-2
JP5	COM2 Port Setting: RS-232	Short 3-5, 4-6
JP6	COM2 Port Setting: RS-232	Short 3-5, 4-6
JP7	Power Supply Selection: AT power supply	Short 1-2
JP8	COM1: Pin 1=Signal/+5V Selection Default: COM Signal	Short 2-3
JP9	COM2: Pin1=Signal/+5V Selection Default: COM Signal	Short 2-3
JP10	COM4: Pin 1=Signal/+5V Selection Default: COM Signal	Short 2-3
JP11	COM3: Pin 1=Signal/+5V Selection Default: COM Signal	Short 2-3
JP12	Compact Flash Voltage Selection Default: 3.3V	Short 1-2

3.3.1 Watchdog Timer Trigger Mode Setting: JP1

The watchdog timer is an indispensable feature of the **SBC84600**. It has a sensitive error detection function and a report function. When the CPU processing comes to a halt, the watchdog either generates a NMI or resets the CPU.

Options	Setting
NMI	Short 1-2
RESET	Short 2-3
Disabled (default)	Open

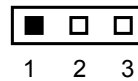

3.3.2 Power Selection of Flat Panel Connector (VDDM of LCD1 and LCD2): JP2

SBC84600 supports +5V flat panel displays. Configure the jumper **JP2** to the appropriate voltage of the flat panel

VDDM	Settings
5V	Short 1-2

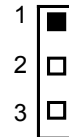

3.3.3 CMOS Clear Jumper: JP3

Options	Settings
Clear CMOS	Short 2-3
Normal (default)	Short 1-2

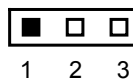

3.3.4 COM2 RS232/422/485 Settings: JP4, JP5, JP6

COM2	JP4	JP5	JP6
RS-232 (default)	Short 1-2	Short 3-5, 4-6	Short 3-5, 4-6
RS-422	Short 3-4	Short 1-3, 2-4	Short 1-3, 2-4
RS-485	Short 5-6, 7-8	Short 1-3, 2-4	Short 1-3, 2-4

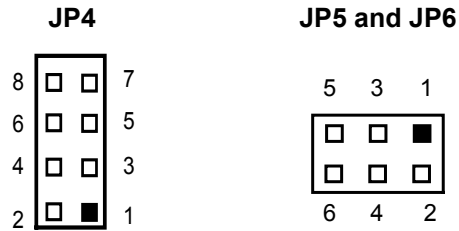

3.3.5 Power Supply Type Selection: JP7

Options	Settings
AT P/S	Short 1-2(default)
ATX P/S	Short 2-3

JP7

3	<input type="checkbox"/>
2	<input type="checkbox"/>
1	<input checked="" type="checkbox"/>

3.3.6 COM2 Signal/+5V Selection: JP8

Options	Setting
Pin 1=+5V	Short 1-2
Pin 1=DCD	Short 2-3 (default)

JP8

3	<input type="checkbox"/>
2	<input type="checkbox"/>
1	<input checked="" type="checkbox"/>

3.3.7 COM1 Signal/+5V Selection: JP9

Options	Setting
Pin 1=+5V	Short 1-2
Pin 1=DCD	Short 2-3(default)

JP9

3

2

1

3.3.8 COM4 Signal/+5V Selection: JP10

Options	Setting
Pin 1=+5V	Short 1-2
Pin 1=DCD	Short 2-3 (default)

JP10

3

2

1

3.3.9 COM3 Signal/+5V Selection: JP11

Options	Setting
Pin 1=+5V	Short 1-2
Pin 1=DCD	Short 2-3 (default)

JP11

3

2

1

3.3.10 Compact Flash Voltage Selection: JP12

Options	Setting
5V	Short 2-3
3.3V	Short 1-2(default)

JP12

3

2

1

3.4 Connectors

The connectors allow the CPU Board to connect with other parts of the system. Ensure that all connectors are in place and firmly attached. The following table lists the function of each connector on the **SBC84600**.

Connectors	Label
44 Pin IDE Connector	CN1
44-pin LCD Connector	CN2
Flat Panel Bezel Connector	CN3
20-pin LCD Connector	CN4
CPU FAN +5V Connector	CN5
Printer Port Connector	CN7
Digital I/O Port Connector	CN8
ATX Power On/Off Button	CN9
Power Input Connectors	CN10
IrDA Connector	CN11
AC97 Link Interface	CN12
Keyboard and Mouse Connector	CN13
TV Connector	CN14
FDD Connector	CN15
USB connector	USB1, USB2
VGA CRT Connector	VGA1
Ethernet Connector	LAN1
PC/104 Connector	J1, J2
COM Connector	COM1
COM Connector	COM2
COM Connector	COM3
COM Connector	COM4
Compact Flash Connector	CF1
VIDEO Connector	VIDEO1
Temperature sensor	JP17

3.4.1 Enhanced IDE Interface Connector: CN1

The **SBC84600** includes a PCI bus enhanced IDE controller that can support master/slave mode and post write transaction mechanisms with 64-byte buffer and master data transaction.

44-pin IDE Interface Connector:

Pin	Description	Pin	Description	Pin	Description
1	Reset #	2	GND	3	Data 7
4	Data 8	5	Data 6	6	Data 9
7	Data 5	8	Data 10	9	Data 4
10	Data 11	11	Data 3	12	Data 12
13	Data 2	14	Data 13	15	Data 1
16	Data 14	17	Data 0	18	Data 15
19	GND	20	No connector	21	No connector
22	GND	23	IOW #	24	GND
25	IOR #	26	GND	27	IOCHRDY
28	No connector	29	No connector	30	GND-Default
31	Interrupt	32	No connector	33	SA1
34	No connector	35	SA0	36	SA2
37	HDC CS0 #	38	HDC CSI #	39	HDD Active #
40	GND	41	VCC	42	VCC
43	GND	44	N.C		

3.4.2 Flat Panel Bezel Connector: CN3

CN3

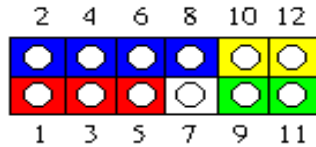

Power LED

This 2-pin connector, designated at **Pins 1** and **3,5**, connects the system power LED indicator to its respective switch on the case. **Pin 1** is +, and **pin 3,5** is assigned as -. The Power LED lights up when the system is powered ON.

External Speaker and Internal Buzzer Connector

Pins 2, 4, 6, and **8 of CN3** connect to the case-mounted speaker unit or internal buzzer. **Short pins 4-6** when connecting the CPU card to an internal buzzer. When connecting an external speaker, set these jumpers to **Open** and install the speaker cable on **pin 8 (+)** and **pin 2 (-)**.

System Reset Switch

Pins 9 & 11 of CN3 connect to the case-mounted reset switch and allow rebooting of your computer instead of turning OFF the power switch. This is a preferred method of rebooting in order to prolong the life of the system's power supply.

HDD Activity LED

This connector extends to the hard drive activity LED on the control panel. This LED will flash when the HDD is being accessed. **Pins 10 & 12 of CN3** connect the hard disk drive and the front panel HDD LED. **Pins 10** is -, and **pin 12** is assigned as +.

3.4.3 VGA/Flat Panel Connector: VGA1, CN2, CN4

The **SBC84600** has three connectors that support CRT VGA and flat panel displays, individually or simultaneously. **VGA1** is a standard 15-pin pin header connector commonly used for the CRT VGA display, and **CN2** (44-pin) **CN4** (20-pin) are dual-in-line headers for the flat panel connection. Configuration of the VGA interface is done via the software utility and no jumper setting is required. The following two tables are the pin assignments for the CRT/VGA connector and the flat panel connector.

VGA1: CRT/VGA Connector Pin Assignment

Pin	Description	Pin	Description	Pin	Description
1	Red	2	Green	3	Blue
4	N/A	5	GND	6	AGND
7	AGND	8	AGND	9	N/A
10	GND	11	N/A	12	DDC DAT
13	Horizontal Sync	14	Vertical Sync	15	DDC CLK

CN2: Flat Panel Connector Pin Assignment

Pin	Description	Pin	Description	Pin	Description
1	-12V	2	+12VM	3	GND
4	GND	5	VDDM	6	VDDM
7	ENAVEE	8	GND	9	P0
10	P1	11	P2	12	P3
13	P4	14	P5	15	P6
16	P7	17	P8	18	P9
19	P10	20	P11	21	P12
22	P13	23	P14	24	P15
25	P16	26	P17	27	P18
28	P19	29	P20	30	P21
31	P22	32	P23	33	GND
34	GND	35	SHFCLK	36	FLM
37	M	38	LP	39	GND
40	ENABKL	41	GND	42	-SHFCLK
43	VDDM	44	VDDM		

CN4: Flat Panel Connector for XVGA

Pin	Description	Pin	Description	Pin	Description
1	GND	2	GND	3	P24
4	P25	5	P26	6	P27
7	P28	8	P29	9	GND
10	GND	11	P30	12	P31
13	P32	14	P33	15	P34
16	P35	17	VDDM	18	VDDM
19	+12VM	20	+12VM		

3.4.3.1 Flat Panel Connector Pin Description

Name	Description
P0~P35	Flat panel data output
ENABKL	Activity Indicator and Enable Backlight outputs
SHFCLK	Shift clock. Pixel clock for flat panel data
M	M signal for panel AC drive control
LP	Latch pulse. Flat panel equivalent of HSYNC
FLM	First line marker. Flat panel equivalent of VSYNC
+12VM	+12V power controlled by chipset
ENAVEE / ENAVDD	Power sequencing controls for panel LCD bias volt
VDDM	5V power controlled by chipset and selected by JP2

3.4.3.2 Flat Panel Interface Pins for Color DSTN and Color TFT LCD (Twister-T VT8606)

Pin	STN			DSTN
	8-bit	16-bit	24-bit	8-bit
LP	LP	LP	HSYNC	HSYNC
FLM	FP	FP	VSYNC	VSYNC
SHFCLK	XCK	XCK	CK	CK
M	DE	DE	DE	DE
ENAVDD	ENAVDD	ENAVDD	ENAVDD	ENAVDD
ENABLK	ENABLK	ENABLK	ENABLK	ENABLK
P0	R0	R0	R0	LR0
P1	G0	G0	G0	
P2	B0	B0	B0	LG0
P3	R1	R1	R1	
P4	G1	G1	G1	LB0
P5	B1	B1	B1	
P6	R2	R2	R2	LR1
P7	G2	G2	G2	
P8		B2	B2	
P9		R3	R3	
P10		G3	G3	
P11		B3	B3	
P12		R4	R4	
P13		G4	G4	
P14		B4	B4	
P15		R5	R5	
P16			G5	
P17			B5	
P18			R6	UR0
P19			G6	
P20			B6	UG0
P21			R7	
P22			G7	UB0
P23			B7	
P24				UR1

Pin	DSTN		TFT	
	16-bit	24-bit	9-bit	2K9-bit
LP	LP	LP	HSYNC	HSYNC
FLM	FP	FP	VSYNC	VSYNC
SHFCLK	XCK	XCK	CK	CK
M	DE	DE	DE	DE
ENAVDD	ENAVDD	ENAVDD	ENAVDD	ENAVDD
ENABLK	ENABLK	ENABLK	ENABLK	ENABLK
P0		LB3		
P1		LB2		
P2	LB1	LB1		
P3	LB0	LB0		
P4		UB3		
P5		UB2		
P6	UB1	UB1	R0	R00
P7	UB0	UB0		R10
P8		LG3	R1	R01
P9		LG2		R11
P10	LG1	LG1	R2	R02
P11	LG0	LG0		R12
P12		UG3		
P13		UG2		
P14	UG1	UG1		
P15	UG0	UG0		
P16		LR3		
P17		LR2		
P18	LR1	LR1	G0	G00
P19	LR0	LR0		G10
P20		UR3	G1	G01
P21		UR2		G11
P22	UR1	UR1	G2	G02
P23	UR0	UR0		G12
P30			B0	B00
P31				B10
P32			B1	B01
P33				B11
P34			B2	B02
P35				B12

Pin	TFT		TFT	
	12-bit	2X12-bit	15-bit	2X15-bit
LP	LP	LP	HSYNC	HSYNC
FLM	FP	FP	VSYNC	VSYNC
SHFCLK	XCK	XCK	CK	CK
M	DE	DE	DE	DE
ENAVDD	ENAVDD	ENAVDD	ENAVDD	ENAVDD
ENABLK	ENABLK	ENABLK	ENABLK	ENABLK
P0				
P1				
P2			R0	R00
P3				R10
P4	R0	R00	R1	R01
P5		R10		R11
P6	R1	R01	R2	R02
P7		R11		R12
P8	R2	R02	R3	R03
P9		R12		R13
P10	R3	R03	R4	R04
P11		R13		R14
P12				
P13				
P14			G0	G00
P15				G10
P16	G0	G00	G1	G01
P17		G10		G11
P18	G1	G01	G2	G02
P19		G11		G12
P20	G2	G02	G3	G03
P21		G12		G13
P22	G3	G03	G4	G04
P23		G13		G14
P24				
P25				
P26			B0	B00
P27				B10

Pin	TFT		TFT	
	12-bit	2X12-bit	15-bit	2X15-bit
P28	B0	B00	B1	B01
P29		B10		B11
P30	B1	B01	B2	B02
P31		B11		B12
P32	B2	B02	B3	B03
P33		B12		B13
P34	B3	B03	B4	B04
P35		B13		B14

Pin	TFT		TFT	
	18-bit	24-bit	2X18-bit	
LP	LP	LP	HSYNC	
FLM	FP	FP	VSYNC	
SHFCLK	XCK	XCK	CK	
M	DE	DE	DE	
ENAVDD	ENAVDD	ENAVDD	ENAVDD	
ENABLK	ENABLK	ENABLK	ENABLK	
P0		B0	R00	
P1		B1	R10	
P2	B0	B2	R01	
P3	B1	B3	R11	
P4	B2	B4	R02	
P5	B3	B5	R12	
P6	B4	B6	R03	
P7	B5	B7	R13	
P8		G0	R04	
P9		G1	R14	
P10	G0	G2	R05	
P11	G1	G3	R15	
P12	G2	G4	G00	
P13	G3	G5	G10	
P14	G4	G6	G01	
P15	G5	G7	G11	
P16		R0	G02	
P17		R1	G12	
P18	R0	R2	G03	
P19	R1	R3	G13	

Pin	TFT		TFT	
	18-bit	24-bit	2X18-bit	
P20	R2	R4	G04	
P21	R3	R5	G14	
P22	R4	R6	G05	
P23	R5	R7	G15	
P24			B00	
P25			B10	
P26			B01	
P27			B11	
P28			B02	
P29			B12	
P30			B03	
P31			B13	
P32			B04	
P33			B14	
P34			B05	
P35			B15	

3.4.4 CPU Fan Connector: CN5

Pin	Description
1	GND
2	+5V



3.4.5 Parallel Port: CN7

The **SBC84600** has a multi-mode parallel port, **CN7**, to support:

- **Standard mode:**
IBM PC/XT, PC/AT and PS/2™ compatible with bi-directional parallel port
- **Enhanced mode:**
Enhance parallel port (EPP) compatible with EPP 1.7 and EPP 1.9 (IEEE 1284 compliant)
- **High speed mode:**
Microsoft and Hewlett Packard extended capabilities port (ECP) IEEE 1284 compliant

The address select of the onboard parallel port in LPT1 (3BCH) or disabled is done by BIOS CMOS setup.

Pin	Description	Pin	Description
1	Strobe#	2	Auto Form Feed#
3	Data 0	4	Error#
5	Data 1	6	Initialize#
7	Data 2	8	Printer Select In#
9	Data 3	10	GND
11	Data 4	12	GND
13	Data 5	14	GND
15	Data 6	16	GND
17	Data 7	18	GND
19	Acknowledge#	20	GND
21	Busy	22	GND
23	Paper Empty#	24	GND
25	Printer Select	26	NC

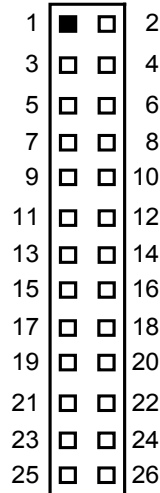

3.4.6 Digital I/O Port (DIO1): CN8

The board is equipped with an 8-channel digital I/O connector **CN8** that meets a system customary automation control needs. The digital I/O can be configured to control the cash drawer, or to sense the warning signal of an Uninterrupted Power System (UPS), or to perform the store security control. The digital I/O is controlled via software programming.

Digital I/O Connector: CN8

Pin	Signal	Pin	Signal
1	DIO Out 0	2	DIO In 0
3	DIO Out 1	4	DIO In 1
5	DIO Out 2	6	DIO In 2
7	DIO Out 3	8	DIO In 3
9	DIO Out 4	10	DIO In 4
11	DIO Out 5	12	DIO In 5
13	DIO Out 6	14	DIO In 6
15	DIO Out 7	16	DIO In 7
17	GND	18	GND
19	NC	20	NC

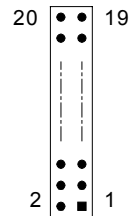

3.4.6.1 Digital I/O Software Programming

The Digital I/O on the board is not an isolated type.

Output	Address	Bit	Output	Address	Bit
Out-0	123h	0	In-0	123h	0
Out-1	123h	1	In-1	123h	1
Out-2	123h	2	In-2	123h	2
Out-3	123h	3	In-3	123h	3
Out-4	123h	4	In-4	123h	4
Out-5	123h	5	In-5	123h	5
Out-6	123h	6	In-6	123h	6
Out-7	123h	7	In-7	123h	7

Example program;

Out 123h, 03h	Out-0, Out-1	Turn On
	Out-2, Out-3	Turn Off
Out 123h, 0Ah	Out-0, Out-2	Turn Off
	Out-1, Out-3	Turn On

Example program;

If INPUT 123 is

(1011), then INPUT-2 is "0"

If INPUT 123 is (1100), then INPUT-0 & 1 are "0"

** The INPUT signal has to be TTL signal

3.4.7 ATX Power On /Off Button: CN9

This 2-pin connector, **CN9**, connects the ATX power button of the front panel to the Board allowing user to control the power on/off state of the ATX power supply. This jumper is only useful when installing an ATX power supply.

Pin	Signal Name
1	GND
2	PW_BN+



3.4.8 Power Input Connector: CN10

The following table is the pin assignment for the standard power supply with both 5V and 12V inputs. However, with 5V only input power, this card still runs in full functions, except the 12V LCD interface, Audio, or +12V PC104 interface is required.

Pin	Description
1	+5V
2	GND
3	+12V
4	SB5V
5	PS_ON
6	-12V
7	GND
8	+5V



3.4.9 IrDA Connector: CN11

CN11 is a 5-pin IrDA connector for wireless communication.

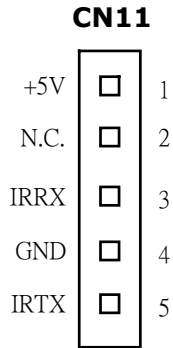

3.4.10 AC97 Interface Link Connector: CN12

CN12 is an AC97 Interface Link Connector for Audio Kit, AX93102.

Please see Section 4.6 for further description.

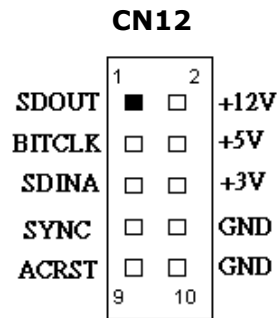

3.4.11 Keyboard and PS/2 Mouse Connectors: CN13

The **SBC84600** provides a keyboard and Mouse interface. **CN13** is a DIN connector for PS/2 keyboard Connection VIA "Y" Cable

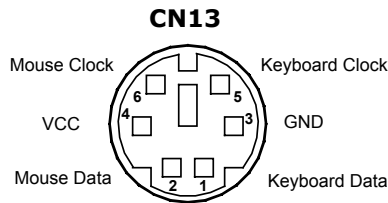

3.4.12 Composite Video Output: CN14, VIDEO1 (Optional Feature)

The **SBC84600** provides a PC99 compliant solution for TV output.

Composite Video Output: CN14

Pin	Signal
1.	COMP/Y/G
2	GND

S-Video Output: VIDEO1

Pin	Signal
1	GND
2	CSYNC
3	CHROMA/V/R
4	LUMA/U/B

The S-Video Output is use a 4 pin Wafer with box 2.0mm

3.4.13 FDD Connector: CN15

The **SBC84600** provides a 26-pin FCC Z.I.F. type connector, and the general output supports a single floppy drives. The floppy drive could be any one of the following types: 3.5" 720KB or 1.44MB/2.88MB.

CN15: FDD Connector Pin Assignment

Pin	Description	Pin	Description
1	+5V	14	STEP
2	INDEX	15	GND
3	+5V	16	WDATA
4	DRIVE0	17	GND
5	+5V	18	WGATE
6	DSKCHG	19	GND
7	No connector	20	TRK0
8	No connector	21	GND
9	No connector	22	WPT
10	MOTOR ON	23	GND
11	No connector	24	RDATA
12	DIR	25	GND
13	No connector	26	HDSEL

3.4.14 USB Connectors: USB1 and USB2

There are two USB connectors allow installation of USB devices. USB1 is 4-pin header connector, and USB2 is a single standard USB connector. The following table shows the pin outs of the USB connectors.

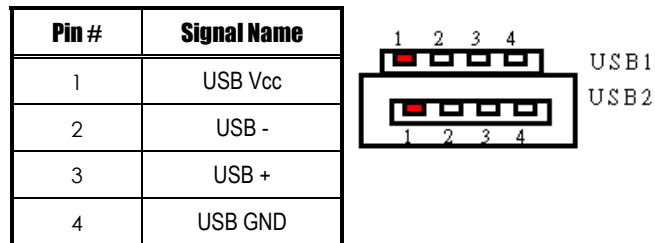

3.4.15 Ethernet PJ-45 Connector: LAN1

The **SBC84600** is equipped with a high performance Plug and Play Ethernet interface which is fully compliant with the IEEE 802.3 standard, and consisting of a RJ-45 connector LAN

3.4.15.1 Pin Assignment

LAN1: RJ-45 Connector Pin Assignment

Pin	Signal
1	Tx+ (Data transmission positive)
2	Tx- (Data transmission negative)
3	Rx+(Data reception positive)
4	RJ45 termination
5	RJ45 termination
6	Rx- (Data reception negative)
7	RJ45 termination
8	RJ45 termination

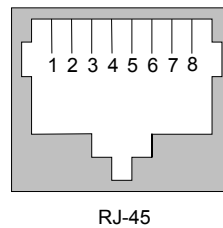

3.4.15.2 Feature

- **10Mb/s and 100Mb/s operations**
- **Supports 10Mb/s and 100Mb/s N-Way auto negotiation**
- **Full duplex capability**
- **Full compliance with PCI Revision 2.1**
- **PCI Bus Master data transfers**

3.4.15.3 Drivers Supported

Bundled with popular software drivers, the **SBC84600** Ethernet interface allows great flexibility to work with all major networking operating systems including Novell NetWare v2.x, v3.x, v4.x, Microsoft LAN Manager, Win3.1, Win NT, Win95, IBM LAN Server, SCO UNIX or other ODI, NDIS and Packet drive compliant operating systems.

3.4.16 PC/104 Connectors: J1 and J2

The PC/104 is an industrial standard. It is a compact form factor with dimensions of 3.6" x 3.8" and is fully compatible with the ISA Bus. The PC/104 interface is able to adapt the off-the-shelf PC/104 modules, such as sound module, fax modem module, multi-I/O module, and etc.

J1: PC/104 Bus Pin Assignment

Pin#	Pin Name	Pin#	Pin Name	Pin#	Pin Name	Pin#	Pin Name
1	IOCHCHK	2	GND	3	SD7	4	RESETDRV
5	SD6	6	+5V	7	SD5	8	IRQ9
9	SD4	10	-5V	11	SD3	12	DRQ2
13	SD2	14	-12V	15	SD1	16	ENDXFR
17	SD0	18	+12V	19	IOCHRDY	20	GND
21	AEN	22	SMEMW	23	SA19	24	SMEMR
25	SA18	26	IOW	27	SA17	28	IOR
29	SA16	30	DACK3	31	SA15	32	DRQ3
33	SA14	34	DACK1	35	SA13	36	DRQ1
37	SA12	38	REFRESH	39	SA11	40	SYSCCLK
41	SA10	42	IRQ7	43	SA9	44	IRQ6
45	SA8	46	IRQ5	47	SA7	48	IRQ4
49	SA6	50	IRQ3	51	SA5	52	DACK2
53	SA4	54	TC	55	SA3	56	SALE
57	SA2	58	+5V	59	SA1	60	OSC
61	SA0	62	GND	63	GND	64	GND

J2: PC/104 Bus Pin Assignments

Pin#	Pin Name	Pin#	Pin Name	Pin#	Pin Name	Pin#	Pin Name
1	GND	2	GND	3	MEMCS16	4	SBHE
5	IOCS16	6	LA23	7	IRQ10	8	LA22
9	IRQ11	10	LA21	11	IRQ12	12	LA20
13	IRQ15	14	LA19	15	IRQ14	16	LA18
17	DACK0	18	LA17	19	DRQ0	20	MEMR
21	DACK5	22	MEMW	23	DRQ5	24	SD8
25	DACK6	26	SD9	27	DRQ6	28	SD10
29	DACK7	30	SD11	31	DRQ7	32	SD12
33	+5V	34	SD13	35	MASTER	36	SD14
37	GND	38	SD15	39	GND	40	(KEY)

3.4.17 Serial Port Interface

3.4.17.1 COM Port Connector: COM1

The connector, COM 1, is a DB-9 connector, and the following table shows the pin assignments of this connector.

Pin	Signal Name
1	DCD, Data carrier detect
2	RXD, Receive data
3	TXD, Transmit data
4	DTR, Data terminal ready
5	GND, ground
6	DSR, Data set ready
7	RTS, Request to send
8	CTS, Clear to send
9	RI, Ring indicator

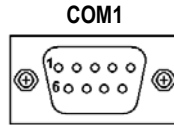

3.4.17.2 COM Port Connectors: COM2, COM3, COM4

The RS-232 pin assignments are listed on the following table.

Pin	Description	Pin	Description
1	Data Carrier Detect (DCD)	2	Data Set Ready (DSR)
3	Receive Data (RXD)	4	Request to Send (RTS)
5	Transmit Data (TXD)	6	Clear to Send (CTS)
7	Data Terminal Ready (DTR)	8	Ring Indicator (RI)
9	Ground (GND)	10	NC

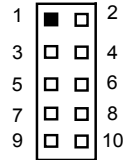

The RS-422/485 pin assignments for COM2 are listed below.

Pin #	Signal Name	
	R2-422	RS-485
1	TX-	DATA-
2	No connector	No connector
3	TX+	DATA+
4	No connector	No connector
5	RX+	No connector
6	No connector	No connector
7	RX-	No connector
8	No connector	No connector
9	GND	GND
10	No connector	No connector

3.4.18 Compact Flash Connector: CF1

The SBC84600VE Series is equipped with a CompactFlash disk socket on the solder side and it supports the IDE2 interface CompactFlash disk card. The socket itself is specially designed to prevent any incorrect installation of the CompactFlash disk card. When installing or removing the CompactFlash disk card, make sure the system power is off. The CompactFlash disk card is defaulted as the E: or F: disk drive in the PC system.

3.4.19 Temperature Sensor

RT1: CPU Temperature Sensor Connector Pin Assignment

Pin	Description
1	Temperature sensor
2	GND

RT2: System Temperature Sensor Connector Pin Assignment

Pin	Description
-----	-------------

1	Temperature sensor
2	GND

This page does not contain any information.

Chapter 4

Hardware Description

This chapter gives a detailed explanation of the hardware features of the **SBC84600** CPU Board.

4.1 Microprocessors

The **SBC84600** supports VIA EDEN 400MHz, 667MHz, or C3 800MHz, C3 1G CPU (other frequency processors are manufacturer optional). Systems based on these CPUs can be operated under Windows XP/NT/2000/98/Me and MS-DOS environments. The system performance depends on the installed CPU on the board.

4.2 BIOS

The system BIOS used in **SBC84600** is Award Plug and Play BIOS. The **SBC84600** contains a single 4M-bit Flash EPROM.

4.3 Real Time Clock and CMOS RAM

The **SBC84600** contains VT82C686B Integrated Real Time Clock (RTC) and 128 bytes of CMOS RAM. The CMOS RAM stores the system configuration information entered via the SETUP program. A battery, with power lasting 10 years, keeps the stored information on the RTC and CMOS RAM active when system power is turned off.

4.4 System Memory

SBC84600 has one onboard 144-pin SODIMM socket that supports 16MB, 32MB, 64MB, 128MB, 256MB, and up to 512MB SODIMM modules.

4.5 VGA Interface

The Twister-T integrates S3 Graphics '128-bit ProSavage4 graphics accelerator into a single chip. TwisterT brings mainstream graphics performance to the Value PC with leading-edge 2D, 3D and DVD video acceleration into a cost effective package. Based on its capabilities, Twister-T is an ideal solution for the consumer, corporation users and entry-level professionals. The industry 's first integrated AGP 4X solution, TwisterT combines AGP 4X performance with Microsoft Direct-X texture compression and passive 2Kx2K textures to deliver unprecedented 3D.

- **High-Performance 3D Accelerator**
- **128-bit 2D Graphics Engine**
- **DVD Playback and Video interfacing**
- **LCD and Flat Panel Monitor Support**
- **High Screen Resolution CRT Support**

4.6 Audio

The AX93102 is an AC'97 external interface board which uses VIA VT1612A and LM4880M ◦

VT1612A is 18-bits audio CODEC conforms to the AC'97 version 2.2 and the S/PDIF specification. Plug and Play device that supports MIC input, Line-In input and CD-In input.

LM4880M is dual audio power amplifier capable of delivering typically 0.25 Watts per channel of continuous average power to an 8 OHM load with 0.1% THD+N using a 5 Voltage power. The Plug and Play device supports 0.5 Watts of Speaker-Out ◦

4.6.1 Board Layout

The board size is 27mm X 40 mm

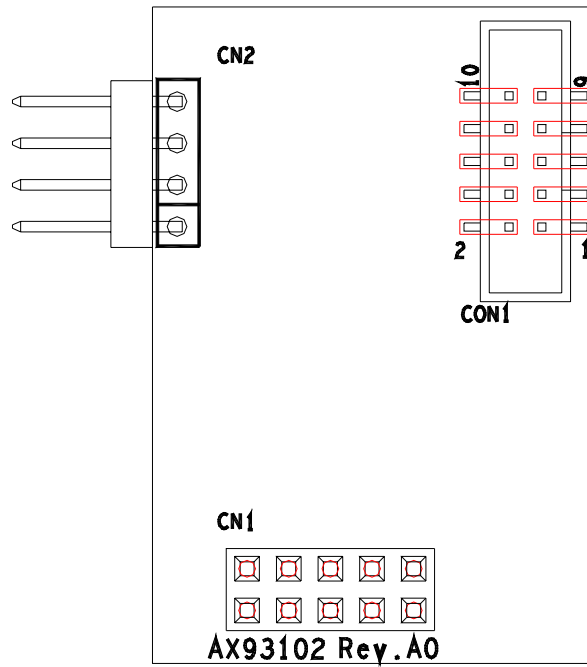

● **Pin-Assignment**

CN1:AC'97 Interface

2	4	6	8	10
1	3	5	7	9

1:AC-OUT 2:+12V
 3:AC-BIT 4:VCC5
 5:AC-IN 6:VCC3
 7:AC-SYNC 8:GND
 9:AC-RST 10:GND

CN2:CD-IN

4	1:CD-LIFT
3	2:CD-GND
2	3:CD-GND
1	4:CD-RIGHT

CON1:PHONE JACK

10	9	1:MIC	2:GND
8	7	3:LINE-IN-L	4:GND
6	5	5:LINE-IN-R	6:GND
4	3	7:LINE-OUT-L	8:GND
2	1	9:LINE-OUT-R	10:GND

4.7 I/O Port Address Map

The CPU card communicates via I/O ports. It has a total of 1KB port addresses that can be assigned to other devices via I/O expansion cards.

Address	Devices
000-01FH	DMA controller #1
020-03FH	Interrupt controller #1
040-05FH	Timer
060-06FH	Keyboard controller
070-07FH	Real time clock, NMI
080-09FH	DMA page register
0A0-0BFH	Interrupt controller #2
0F0H	Clear math coprocessor busy signal
0C0-0DFH	DMA controller #2
0F1H	Reset math coprocessor
0F8-0FFH	Math processor
120H	Disable watchdog timer operation (read)
121H	Enable watchdog timer operation (read)
122H	Watchdog
123H	Digital I/O
1F0-1F8H	Fixed disk controller
200-207H	Game port
300-31FH	Prototype card
360-36FH	Reserved
378-37FH	Parallel port #1
3B0-3BFH	MDA video card (including LPT1)
3C0-3CFH	EGA card
3D0-3DFH	CGA card
3F0-3F7H	Floppy disk controller

Address	Devices
3F8-3FFH	Serial port #1 (COM1)
2F8-2FFH	Serial port #2 (COM2)
3E8-3EFH	Serial port #3 (COM3)
2E8-2EFH	Serial port #4 (COM4)

4.8 Interrupt Controller

The **SBC84600** is a fully PC compatible control board. It consists of 16 ISA interrupt request lines and 4 of the 16 can be either ISA or PCI. The mapping list of the 16 interrupt request lines is shown below;

NMI	Parity check error
IRQ0	System timer output
IRQ1	Keyboard
IRQ2	Interrupt rerouting from IRQ8 through IRQ15
IRQ3	Serial port #2
IRQ4	Serial port #1
IRQ5	Reserved
IRQ6	Floppy disk controller
IRQ7	Parallel port #1
IRQ8	Real time clock
IRQ9	Reserved
IRQ10	Serial port #2
IRQ11	Serial port #2
IRQ12	PS/2 Mouse
IRQ13	Math coprocessor
IRQ14	Primary IDE channel
IRQ15	Secondary IDE Channel

Chapter 5

Award BIOS Utility

Chapter 5 describes the different settings available in the Award BIOS that comes with the **SBC84600** CPU card. Also, the instructions on how to set up the BIOS configuration are contained in this chapter.

5.1 BIOS Introduction

The Award BIOS (Basic Input/Output System) installed in the system ROM supports Intel Celeron processors in a standard IBM-AT compatible I/O system. The BIOS provides critical low-level support for standard devices such as disk drives, serial and parallel ports. It also adds virus and password protection as well as special support for detailed fine-tuning of the chipset controlling the entire system.

5.2 BIOS Setup

The Award BIOS provides a Setup utility program for specifying the system configurations and settings. The BIOS ROM of the system stores the Setup utility. When the computer is turned ON, the Award BIOS is immediately activated. The following message will appear on the screen:

Press to Enter Setup

Then, press the key immediately to enter the Setup utility. The delay of pressing the key will cause POST (Power On Self Test) to continue with the test routines, thus preventing invoking the Setup. In this case, the system has to be restarted for entering the BIO setup by pressing the "Reset" button or simultaneously pressing the <Ctrl>, <Alt> and <Delete> keys. Besides, turning the system OFF first and then ON again can also restart the system.

When entering the Setup utility, the Main Menu screen will appear on the screen. Various setup functions and exit choices can be selected from this menu.

In general, the arrow keys are used to highlight items, <Enter> to select, the <PgUp> and <PgDn> keys to change entries, <F1> for help and <Esc> to quit.

Phoenix – AwardBIOS CMOS Setup Utility	
▶ Standard CMOS Features	▶ Frequency/Voltage Control
▶ Advanced BIOS Features	Load Fail-Safe Defaults
▶ Advanced Chipset Features	Load Optimized Defaults
▶ Integrated Peripherals	Set Supervisor Password
▶ Power Management Setup	Set User Password
▶ PnP/PCI Configurations	Save & Exit Setup
▶ PC Health Status	Exit Without Saving
Esc : Quit F9: Menu in BIOS ↑ ↓ → ← : Select Item	
F10 : Save & Exit Setup	
Time, Date, Hard Disk Type...	

The section below the setup items in the Main Menu displays the control keys for this menu. Another section located at the bottom of the Main Menu, just below the control keys section, displays information on the currently highlighted item in the list.

NOTE: *If the computer cannot boot after making and saving system changes with Setup, the Award BIOS, via its built-in override feature, resets your system to the CMOS default settings.*

Avoid making any changes to the chipset defaults are strongly recommended. These defaults have been carefully chosen by both Award and the system manufacturer to provide the absolute maximum performance and reliability.

5.2.1 Standard CMOS Setup

“Standard CMOS Setup” is used to record some basic hardware configurations in the computer system and set the system clock and error handling. If the motherboard is already installed in a working system, there is no need to enter this option. However, the Standard CMOS option has to be setup in any of the following situations: the system hardware configurations are changed, the onboard battery fails, and the configuration stored in the CMOS memory is lost or damaged.

Phoenix – Award BIOS CMOS Setup Utility		
Standard CMOS Features		
Date (mm:dd:yy)	Wed, 7 2002	Item Help
Time (hh:mm:ss)	13 : 9 : 11	
▶ IDE Primary Master	None	Menu Level ▶
▶ IDE Primary Slave	None	Change the
▶ IDE Secondary Master	None	Day, month,
▶ IDE Secondary Slave	None	Year and
		Century
Drive A	1.44M, 3.5 in.	
LCD Type	T9 800x600 TFT	
Screen Expansion	Enable	
TV Type	NTSC	
Display Type During Post	VGA Default	
Display Type After Post	VGA Default	
Halt on	All, But keyboard	
Base Memory	640K	
Extended Memory	65535K	
↑↓→← : Move Enter: Select +/-/PU/PD: Value F10: Save ESC: Exit F1: General Help F5: Previous Values F6: Fail-Safe Defaults F7: Optimized Defaults		

At the bottom of the menu are the control keys for the use of this menu. The <F1> key can be pressed in each item field to display the relevant information for help. The memory display at the lower right-hand side of the menu is read-only. It will adjust automatically according to the memory changed. The following pages describe each item of this menu.

- **Date**

The date format is <day>, <date> <month> <year>. Press <F3> to show the calendar.

day	The day of week, from Sun to Sat, determined by the BIOS, is read only
date	The date, from 1 to 31 (or the maximum allowed in the month), can key in the numerical / function key
month	The month, Jan through Dec.
year	The year, depends on the year of BIOS

- **Time**

The time format is <hour> <minute> <second> accepting either function key or numerical key. The time is calculated based on the 24-hour military-time clock. For example, 1 p.m. is 13:00:00.

- **IDE Primary Master / Primary Slave / Secondary Master / Secondary Slave**

This category identifies the type of the channel that is installed in the computer. There are 45 predefined types and 2 user definable types for Enhanced IDE BIOS. Type 1 to Type 45 are predefined. Type User is user-definable.

Press <PgUp>/<+> or <PgDn>/<-> to select a numbered hard disk type or type the number and press <Enter>. Note that the specifications of the drive in the system must match with the drive table. The hard disk will not work properly if the improper information within this category is entered. If the disk drive type does not match or is not listed, the Type User is used to define the drive type manually.

If the Type User is selected, related information has to be entered. Enter the information directly from the keyboard and press <Enter>. This information should be provided in the documentation from the hard disk vendor or the system manufacturer.

If the controller of HDD interface is ESDI, select "Type 1".

If the controller of HDD interface is SCSI, select "None".

If the controller of HDD interface is CD-ROM, select "None".

CYLS.	number of cylinders	LANDZONE	landing zone
HEADS	number of heads	SECTORS	number of sectors
PRECOMP	write precom	MODE	HDD access mode

If there is no hard disk drive installed, select NONE and press <Enter>.

- **Drive A type/Drive B type**

The category identifies the types of floppy disk drive A or drive B installed in the computer.

None	No floppy drive installed
360K, 5.25 in	5.25 inch PC-type standard drive; 360Kb capacity
1.2M, 5.25 in	5.25 inch AT-type high-density drive; 1.2MB capacity
720K, 3.5 in	3.5 inch double-sided drive; 720Kb capacity
1.44M, 3.5 in	3.5 inch double-sided drive; 1.44MB capacity
2.88M, 3.5 in	3.5 inch double-sided drive; 2.88MB capacity

- **Select Display Device**

This item selection includes Auto, CRT, LCD and CRT+LCD

- **LCD Type**

This item selection includes:

T0 640x480 TFT	T1 800x600 TFT
T2 1024x768 TFT	T3 1280x1024 TFT
T4 640x480 DSTN	T5 800x600 DSTN
T6 1024x768 DSTN	T7 1024x768 TFT
T8 640x480 TFT	T9 800x600 TFT
T10 1024x768 TFT	T11 1280x1024 TFT
T12 1400x1050 DSTN	T13 800x600 DSTN
T14 1024x768 DSTN	T15 1280x1024 DSTN

- **Display Type During Post**

This item selection includes VGA DEFAULT, CRT, LCD, CRT+LCD, TV, and CRT+TV.

- **Display Type After Post**

This item selection includes VGA DEFAULT, CRT, LCD, CRT+LCD, TV, and CRT+TV.

- **Halt On**

This field determines whether the system will halt if an error is detected during power up.

No errors	The system boot will halt on any error detected. (default)
All errors	Whenever the BIOS detects a non-fatal error, the system will stop and you will be prompted.
All, But Keyboard	The system boot will not stop for a keyboard error; it will stop for all other errors.
All, But Diskette	The system boot will not stop for a disk error; it will stop for all other errors.
All, But Disk/Key	The system boot will not stop for a keyboard or disk error; it will stop for all other errors.

5.2.2 Advanced BIOS Features

This section is used to configure and improve the system and set up some system features according to the user's preference.

Phoenix – Award BIOS CMOS Setup Utility Advanced BIOS Features		
		Item Help
Virus Warning	Disabled	Menu Level ► Allows you to choose the VIRUS warning feature for IDE Hard disk boot sector protection. If this function is enable and someone attempts to write data into this area, BIOS will show a warning message on screen and alarm beep
CPU Internal Cache	Enabled	
External Cache	Enabled	
CPU L2 Cache ECC Checking	Enabled	
Processor Number Feature	Enabled	
Quick Power On Self Test	Enabled	
First Boot Device	HDD-0	
Second Boot Device	Floppy	
Third Boot Device	LS120	
Boot Other Device	Enabled	
Swap Floppy Drive	Disabled	
Boot Up Floppy Seek	Enabled	
Boot Up NumLock Status	On	
Gate A20 Option	Fast	
Typematic Rate Setting	Disabled	
Typematic Rate (Chars/Sec)	6	
Typematic Delay (Msec)	250	
Security Option	Setup	
OS Select For DRAM > 64MB	Non-OS2	
Video BIOS Shadow	Enabled	
C8000-CBFFF Shadow	Disabled	
CC000-CFFFF Shadow	Disabled	
D0000-D3FFF Shadow	Disabled	
D4000-D7FFF Shadow	Disabled	
D8000-DBFFF Shadow	Disabled	
DC000-DFFFF Shadow	Disabled	
Small Logo(EPA) Show	Disabled	
↑↓→← : Move Enter: Select +/-/PU/PD: Value F10: Save ESC: Exit F1: General Help F5: Previous Values F6: Fail-Safe Defaults F7: Optimized Defaults		

- **Virus Warning**

This item protects the boot sector and partition table of the hard disk against accidental modifications. If an attempt is made, the BIOS will halt the system and display a warning message. If this occurs, the user can either continue the operation or run an anti-virus program to locate and remove the problem.

NOTE: *Many disk diagnostic programs, which attempt to access the boot sector table, can cause the virus warning. Thus, disable the Virus Warning feature while running any of these programs..*

- **CPU Internal Cache / External Cache**

Cache memory is additional memory that is much faster than conventional DRAM (system memory). CPUs from 486-type and up contain internal cache memory, and most, but not all, modern PCs have additional (external) cache memory. When the CPU requests data, the system transfers the requested data from the main DRAM into cache memory, for even faster access by the CPU. These items are used to enable (speed up memory access) or disable the cache function. By default, these are **Enabled**.

- **CPU L2 Cache ECC Checking**

When enabled, this allows ECC checking of the CPU's L2 cache. By default, this field is **Enabled**.

- **Processor Number Feature**

When a Pentium® III CPU is installed, the system automatically detects it and displays this item.

- **Quick Power On Self Test**

This option speeds up Power On Self Test (POST) after turning on the system power. If it is set as Enabled, BIOS will shorten or skip some check items during POST. The default setting is **"Enabled"**.

Enabled	Enable Quick POST
Disabled	Normal POST

- **First/Second/Third Boot Device**

These items allow the selection of the 1st, 2nd, and 3rd devices that the system will search for during its boot-up sequence. The wide range of selection includes Floppy, LS120, ZIP100, HDD0~3, SCSI, and CDROM.

- **Boot Other Device**

This item allows the user to enable/disable the boot device not listed on the First/Second/Third boot devices option above. The default setting is **Enabled**.

- **Swap Floppy Drive**

This allows you to determine whether to enable Swap Floppy Drive or not. When enabled, the BIOS swaps floppy drive assignments so that Drive A becomes Drive B, and Drive B becomes Drive A. By default, this field is set to *“Disabled”*.

- **Boot Up Floppy Seek**

During POST, BIOS will determine the floppy disk drive type, 40 or 80 tracks. 360Kb type is 40 tracks while 720Kb, 1.2MB and 1.44MB are all 80 tracks. The default value is *“Enabled”*.

Enabled	BIOS searches for floppy disk drive to determine if it is 40 or 80 tracks. Note that BIOS can not tell from 720K, 1.2M or 1.44M drive type as they are all 80 tracks.
Disabled	BIOS will not search for the type of floppy disk drive by track number. There will be no warning message displayed if the drive installed is 360K.

- **Boot Up NumLock Status**

This option enables and disables the numberlock function of the keypad. The default value is *“On”*.

On	Keypad functions confine with numbers
Off	Keypad functions convert to special functions (i.e., left/right arrow keys)

- **Gate A20 Option**

The default value is *“Fast”*.

Normal	The A20 signal is controlled by keyboard controller or chipset hardware.
Fast	Default: Fast. The A20 signal is controlled by Port 92 or chipset specific method.

- **Typematic Rate Setting**

This determines the typematic rate of the keyboard. The default value is *“Disabled”*.

Enabled	Enable typematic rate and typematic delay programming
Disabled	Disable typematic rate and typematic delay programming. The system BIOS will use default value of these 2 items and the default is controlled by keyboard.

- **Typematic Rate (Chars/Sec)**

This option refers to the number of characters the keyboard can type per second. The default value is "6".

6	6 characters per second
8	8 characters per second
10	10 characters per second
12	12 characters per second
15	15 characters per second
20	20 characters per second
24	24 characters per second
30	30 characters per second

- **Typematic Delay (Msec)**

This option sets the display time interval from the first to the second character when holding a key. The default value is "250".

250	250 msec
500	500 msec
750	750 msec
1000	1000 msec

- **Security Option**

This item limits the access to the system and Setup, or just to Setup. The default value is "Setup".

System	The system will not boot and access to Setup will be denied if the incorrect password is entered at the prompt.
Setup	The system will boot, but access to Setup will be denied if the correct password is not entered at the prompt.

NOTE: *To disable security, select PASSWORD SETTING at Main Menu and then password is asked to enter. Do not type anything, just press <Enter> and it will disable security. Once the security is disabled, the system will boot and you can enter Setup freely.*

- **OS Select for DRAM > 64MB**

This segment is specifically created for OS/2 when DRAM is larger than 64MB. If the operating system is OS/2 and DRAM used is larger the 64MB, "OS 2" has to be selected; otherwise (under non-OS2), default is "NON-OS2".

- **Video BIOS Shadow**

Video shadowing increases the video speed by copying the video BIOS into RAM. However, it is still optional depending on the chipset design. The default value of this option is *“Enabled”*.

Enabled	Video BIOS shadowing is enabled
Disabled	Video BIOS shadowing is disabled

- **C8000 - CBFFF Shadow/DC000 - DFFFF Shadow**

Shadowing ROM reduces available memory between 640KB and 1024KB. These fields determine whether optional ROM is copied to RAM or not.

5.2.3 Advanced Chipset Features

Since the features in this section are related to the chipset on the CPU board and are completely optimized, changing the default settings in this setup table are not recommended unless the user is well oriented with the chipset features.

Phoenix – Award BIOS CMOS Setup Utility		
Advanced Chipset Features		
DRAM Timing By SPD	Enabled	Item Help
X DRAM Clock	Host CLK	Menu Level ►
X SDRAM Cycle Length	3	
X Bank Interleave	Disabled	
Memory Hole	Disabled	
P2C/C2P Concurrency	Enabled	
System BIOS Cacheable	Disabled	
Video RAM Cacheable	Disabled	
Frame Buffer Size	16M	
AGP Aperture Size	64M	
AGP-4X Mode	Enabled	
AGP Driving Control	Auto	
AGP Driving Value	DA	
OnChip USB	Enabled	
USB Keyboard Support	Disabled	
OnChip Sound	Auto	
OnChip Modem	Disabled	
CPU to PCI Write Buffer	Enabled	
PCI Dynamic Bursting	Enabled	
PCI Master 0 WS Write	Enabled	
PCI Delay Transaction	Disabled	
PCI#2 Access #1 Retry	Enabled	
AGP Master 1 WS Write	Disabled	
AGP Master 1 WS Read	Disabled	
↑↓→← : Move Enter: Select +/-/PU/PD: Value F10: Save ESC: Exit F1: General Help F5: Previous Values F6: Fail-Safe Defaults F7: Optimized Defaults		

- **DRAM Timing By SPD**

This item is selected depending on whether the board has paged DRAMs or EDO (extended data output) DRAMs.
- **DRAM Clock**

The DRAM clock value is set depending on whether the board has paged DRAMs or EDO (extended data output) DRAMs. The available choices are 66 MHz and Host CLK.
- **SDRAM Cycle Length**

When synchronous DRAM is installed, the number of clock cycles of CAS latency depends on the DRAM timing. Do not reset this field from the default value specified by the system designer. The default setting is **3**.
- **Memory Hole**

To improve performance, certain space in memory is reserved for ISA cards. This memory must be mapped into the memory space below 16MB. The available choices are 15M-16M and Disabled.
- **P2C/C2P Concurrency**

This item enables or disables the PCI to CPU and CPU to PCI concurrency. By default, this field is set to **Enabled**.
- **System BIOS Cacheable**

Selecting “*Enabled*” allows caching of the system BIOS ROM at F0000h-FFFFFh, resulting in better system performance. However, if any program writes to this memory area, a system error may result.
The choice: Enabled, Disabled.
- **Video RAM Cacheable**

Selecting “*Enabled*” allows caching of the A/B segment, resulting in better system performance.
The choice: Enabled, Disabled.
- **AGP Aperture Size**

The field sets aperture size of the graphics. The aperture is a portion of the PCI memory address range dedicated for graphics memory address space. Host cycles that hit the aperture range are forwarded to the AGP without any translation.
The choice: 4M, 8M, 16M, 32M, 64M, 128M and 256M.
- **OnChip USB**

This should be enabled if the system has a USB installed on the system board and the USB will be used. Even when equipped, if a higher performance controller is added, this feature should be disabled.
The choice: Enabled, Disabled.

- **USB Keyboard Support**

Select “*Enabled*” if the system contains a Universal Serial Bus (USB) controller and you have a USB keyboard.
The choice: Enabled, Disabled.
- **CPU to PCI Write Buffer**

When this field is “*Enabled*”, writes from the CPU to the PCI bus are buffered to compensate for the speed differences between the CPU and the PCI bus. When “*Disabled*”, the writes are not buffered and the CPU must wait until the write is complete before starting another write cycle.
- **PCI Dynamic Bursting**

This item is to enable/ disable the PCI dynamic bursting function.
- **PCI Master 0 WS Write**

When “*Enabled*”, writes to the PCI bus are executed with zero wait states.
- **PCI Delay Transaction**

The chipset has an embedded 32-bit posted write buffer to support delay transactions cycles. Select “*Enabled*” to support compliance with PCI specification version 2.1. The default setting is ***Disabled***.
- **PCI#2 Access #1 Retry**

When “*Disabled*”, PCI#2 will not be disconnected until access finishes (default). When “*Enabled*”, PCI#2 will be disconnected if max retries are attempted without success.
- **AGP Master 1 WS Write**

When “*Enabled*”, writes to the AGP (Accelerated Graphics Port) are executed with one wait states.
- **AGP Master 1 WS Read**

When “*Enabled*”, read to the AGP (Accelerated Graphics Port) are executed with one wait states.

5.2.4 Integrated Peripherals

This option sets the hard disk configuration, mode and port.

Phoenix – Award BIOS CMOS Setup Utility		
Integrated Peripherals		
OnChip IDE Channel0	Enabled	Item Help
OnChip IDE Channel1	Enabled	
IDE Prefetch Mode	Enabled	Menu Level ►
Primary Master PIO	Auto	
Primary Slave PIO	Auto	
Secondary Master PIO	Auto	
Secondary Slave PIO	Auto	
Primary Master UDMA	Auto	
Primary Slave UDMA	Auto	
Secondary Master UDMA	Auto	
Secondary Slave UDMA	Auto	
Init Display First	PCI Slot	
IDE HDD Block Mode	Enabled	
Onboard FDD Controller	Enabled	
Onboard Serial Port 1	3F8/IRQ4	
Onboard Serial Port 2	2F8/IRQ3	
UART 2 Mode	Standard	
IR Function Duplex	Half	
TX, RX inverting enable	No, Yes	
Onboard Parallel Port	378/IRQ7	
Onboard Parallel Mode	Normal	
X ECP Mode Use DMA	3	
X Parallel Port EPP Type	EPP1.9	
Onboard Serial Port 3	3E8H	
Serial Port 3 Use IRQ	IRQ 10	
Onboard Serial Port 4	2E8H	
Serial Port 4 Use IRQ	IRQ 11	
Onboard Legacy Audio	Enabled	
X Sound Blaster	Disabled	
X SB I/O Base Address	220H	
X SB IRQ Select	IRQ 5	
X SB DMA Select	DMA 1	
X MPU-401	Disabled	
X MPU-401 I/O Address	330-333H	
↑↓→← : Move Enter: Select +/-/PU/PD: Value F10: Save ESC: Exit F1: General Help F5: Previous Values F6: Fail-Safe Defaults F7: Optimized Defaults		

- **On-Chip IDE Channel0/Channel1**

The integrated peripheral controller contains an IDE interface with support for two IDE channels. Select *“Enabled”* to activate each channel separately.

The choice: Enabled, Disabled.

- **IDE Prefetch Mode**

The onboard IDE drive interface supports IDE prefetching for faster drive accesses. If a primary and/or secondary add-in IDE interface are installed, set this field to *“Disabled”* if the interface does not support prefetching.

- **Primary/Secondary Master/Slave PIO**

The four PIO (Programmed Input/Output) fields sets a PIO mode (0-4) for each of the four IDE devices that the onboard IDE interface supports. Modes 0 through 4 provide successively increased performance. In Auto mode, the system automatically determines the best mode for each device.

The choice: Auto, Mode 0, Mode 1, Mode 2, Mode 3, Mode 4.

- **Primary/Secondary Master/Slave UDMA**

Ultra DMA/33 implementation is possible only if your IDE hard drive supports it and the operating environment includes a DMA driver (Windows 98 or a third-party IDE bus master driver). If the hard drive and the system software both support Ultra DMA/33, select Auto to enable BIOS support.

The Choice: Auto, Disabled.

- **Init Display First**

This item is to active whether PCI Slot or on-chip VGA first.

The choice: PCI Slot, Onboard.

- **IDE HDD Block Mode**

Block mode is also called block transfer, multiple commands, or multiple sector read/write. If the IDE hard drive supports block mode (most new drives do), select *“Enabled”* for automatic detection of the optimal number of block read/writes per sector the drive can support.

The choice: Enabled, Disabled

- **Onboard FDD Controller**

Select *“Enabled”* if the system has a floppy disk controller (FDC) installed on the system board and the FDC will be used. If the and-in FDC are installed or the system has no floppy drive, select *“Disabled”* in this field.

The choice: Enabled, Disabled.

- **Onboard Serial Port 1/Port 2**
Select an address and corresponding interrupt for the first, second and third serial ports.
The choice: 3F8/IRQ4, 2E8/IRQ3, 3E8/IRQ4, 2F8/IRQ3, Disabled, Auto.
- **UART 2 Mode**
This item is to select UART mode. By default, this field is set to *Standard*.
- **IR Function Duplex**
This item is to select the IR half/full duplex function.
- **TX,RX inverting enable**
This item is to enable the TX, RX inverting which depends on different H/W requirement. This field is not recommended to change its default setting for avoiding any error in the system.
- **Onboard Serial Port 3**
This item allows you to determine access onboard serial port 3 with which I/O address. The options available are 3F8H/2F8H/3E8H/2E8H/Disabled.
- **Serial Port 3 Use IRQ**
Select an corresponding interrupt for the 3rd serial port. The options available are IRQ10/11/3/4/5/7/9.
- **Onboard Serial Port 4**
This item allows you to determine access onboard serial port 4 with which I/O address. The options available are 3F8H/2F8H/3E8H/2E8H/Disabled.
- **Serial Port 4 Use IRQ**
Select an corresponding interrupt for the 4th serial port. The options available are IRQ10/11/3/4/5/7/9.
- **Onboard Parallel Port**
This item is to determine access onboard parallel port controller with which I/O address.
The choice: 3BC/IRQ7, 378/IRQ7, 278/IRQ5, Disabled.
- **Onboard Parallel Mode**
Select an operating mode for the onboard parallel (printer) port. Select *Normal*, *Compatible*, or *SPP* unless you are certain your hardware and software both support one of the other available modes.
The choice: SPP, EPP, ECP, ECP+EPP.
- **ECP Mode Use DMA**
Select a DMA channel for the parallel port for use during ECP mode.
The choice: 3, 1.

5.2.5 Power Management Setup

The Power Management Setup is to save energy of the system effectively. It will shut down the hard disk and turn OFF video display after a period of inactivity.

Phoenix – Award BIOS CMOS Setup Utility		
Power Management Setup		
ACPI Function	Disabled	Item Help
Power Management	Press Enter	Menu Level ►
PM Control by APM	Yes	
Video Off Option	Suspend -> Off	
Video Off Method	V/H SYNC+Blank	
MODEM Use IRQ	3	
Soft-Off by PWRBTN	Instant-Off	
Wake Up Events	Press Enter	
↑↓→← : Move Enter: Select +/-/PU/PD: Value F10: Save ESC: Exit F1: General Help F5: Previous Values F6: Fail-Safe Defaults F7: Optimized Defaults		

- **ACPI Function**
This item is to enable/disable the Advanced Configuration and Power Interface (ACPI).
The choice: Enabled, Disabled.
- **Power Management**
This item is to select the Power Management mode.
The choice: User Define, Min Saving, Max Saving.
- **PM Control by APM**
When enabled, an Advanced Power Management device will be activated to enhance the Max. Power Saving mode and stop the CPU internal clock. If Advance Power Management (APM) is installed on the system, selecting "Yes" gives better power savings. If the Max. Power Saving is not enabled, this will be preset to "No".

- **Video Off Option**

When enabled, this feature allows the VGA adapter to operate in a power saving mode.

Always On	Monitor will remain on during power saving modes.
Suspend --> Off	Monitor blanked when the system enters the Suspend mode.
Susp,Stby --> Off	Monitor blanked when the system enters either Suspend or Standby modes.
All Modes --> Off	Monitor blanked when the system enters any power saving mode.

- **Video Off Method**

This determines the manner in which the monitor is blanked.

V/H SYNC + Blank	This causes the system to turn off the vertical and horizontal synchronization ports and write blanks to the video buffer.
DPMS	Select this option if your monitor supports the Display Power Management Signaling (DPMS) standard of the Video Electronics Standards to select video power management values.
Blank Screen	This option only writes blanks to the video buffer.

- **Video Off Method**

In suspending, this item is to select the CRT closed method under APM mode.

The choice: Blank Screen, V/H SYNC+Blank, DPMS

- **MODEM Use IRQ**

APM 1.2 function used only.

The choice: NA, 3, 4, 5, 7, 9, 10, 11

- **Soft-off by PWRBTN**

This only works with the system using an ATX power supply. It also allows user to define the type of soft power OFF sequence for the system to follow.

Instant-Off (default)	This option follows the conventional manner systems perform when power is turned OFF. Instant-Off is a soft power OFF sequence requiring only the switching of the power supply button to OFF.
Delay 4 Sec.	Upon turning OFF system from the power switch, this option will delay the complete system power OFF sequence by approximately 4 seconds. Within this delay period, system will temporarily enter into Suspend Mode enabling you to restart the system at once.

- **Wake Up Events**

An input signal on the network 2 awakens the system from a soft-off state.

5.2.6 PNP/PCI Configuration

This section describes the PCI bus system configuration. PCI or Personal Computer Interconnect is a system which allows I/O devices to operate at speeds nearing the speed of the CPU when communicating with its own special components. This section covers some very technical items, and it is strongly recommended that only experienced users should make changes to the default settings.

Phoenix – Award BIOS CMOS Setup Utility PnP/PCI Configurations		
PNP OS Installed	No	Item Help
Reset Configuration Data	Disabled	
Resources Controlled By	Manual	Menu Level ►
X IRQ Resources	Press Enter	Select Yes if you are using a Plug and play capable operating system select No if you need the BIOS to configure non-boot devices
X DMA Resources	Press Enter	
PCI/VGA Palette Snoop	Disabled	
Assign IRQ For VGA	Enabled	
Assign IRQ For USB	Enabled	
↑↓→← : Move Enter: Select +/-/PU/PD: Value F10: Save ESC: Exit F1: General Help F5: Previous Values F6: Fail-Safe Defaults F7: Optimized Defaults		

- PNP OS Installed**
 This item is to determine install PnP OS or not. The options available are Yes and No.
- Reset Configuration Data**
 Normally, this field is "Disabled". Select "Enabled" to reset Extended System Configuration Data (ESCD). When exiting Setup or installed a new add-on, the system reconfiguration has caused such a serious conflict that the operating system cannot boot. The options available are Enabled and Disabled.

- **Resource controlled by**

The Award Plug and Play BIOS has the capacity to automatically configure all of the boot and the Plug and Play compatible devices. However, this capability means absolutely nothing unless using a Plug and Play operating system such as Windows®98. The options available are Auto and Manual.

- **IRQ Resources**

When resources are controlled manually, assign each system interrupt a type, depending on the type of device using the interrupt.

- **DMA Resources**

When resources are controlled manually, assign each system DMA channel as one of the following types, depending on the type of device using the interrupt:

1. Legacy ISA Devices compliant with the original PC AT bus specification, requiring a specific DMA channel.
2. PCI/ISA PnP Devices compliant with the Plug and Play standard, whether designed for PCI or ISA bus architecture.

The default value is "*PCI/ISA PnP*".

- **PCI/VGA Palette Snoop**

Leave this field at "*Disabled*".

The choice: Enabled, Disabled.

- **Assign IRQ For USB/VGA**

This item is to enable or disable the IRQ assignment for USB/VGA. The options available are Enabled, Disabled

5.2.7 PC Health Status

This section is to monitor the current hardware status of core voltages. This is available only if there is hardware monitoring mechanism onboard.

Phoenix – Award BIOS CMOS Setup Utility	
PC Health Status	
Current CPU Temp.	22°C/71°C
Current System Temp.	22°C/71°C
Vcore	1.06V
2.5V	2.5V
3.3V	3.34V
5V	5.12V
12V	11.84V

↑↓→← : Move Enter: Select +/-PU/PD: Value F10: Save ESC: Exit F1: General Help
F5: Previous Values F6: Fail-Safe Defaults F7: Optimized Defaults

- **2.5V/3.3V/5V/12V**
Show the voltage of 2.5V/3.3V/5V/12V

5.2.8 Frequency/Voltage Control

CMOS Setup Utility-Copyright © 1984-2001 Award Software Frequency/Voltage Control		
Auto Detect DIMM/PCI Clk	Enabled	Menu Level ►
Spread Spectrum	Disabled	
CPU Host/PCI Clock	Default	
↑↓→← : Move Enter: Select +/-/PU/PD: Value F10: Save ESC: Exit F1: General Help F5: Previous Values F6: Fail-Safe Defaults F7: Optimized Defaults		

- **Auto Detect DIMM/PCI Clk**
When enabled, this item will auto detect if the DIMM and PCI socket have devices and will send clock signal to DIMM and PCI devices. When disabled, it will send the clock signal to all DIMM and PCI socket.
The choice: Enabled, Disabled.
- **Spread Spectrum**
This item is to enable/disable the spread spectrum modulate.
The choice: Enabled, Disabled.

5.2.9 Load Fail-Safe Defaults

This option is to load the troubleshooting default values permanently stored in the BIOS ROM. These default settings are non-optimal and disable all high-performance features.

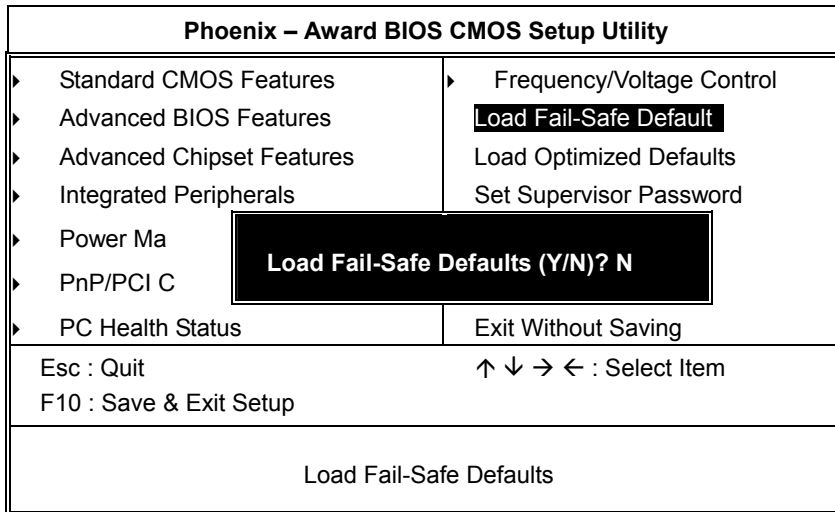

To load BIOS defaults value to CMOS SRAM, enter “Y”. If not, enter “N”.

5.2.10 Load Optimized Defaults

This option is to load the default values to the system configuration. These default settings are optimal and enable all high performance features.

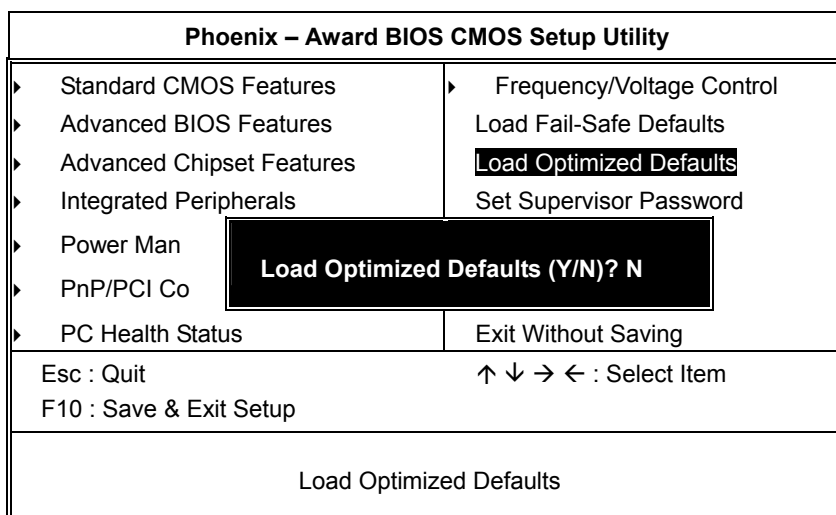

To load SETUP defaults value to CMOS SRAM, enter "Y". If not, enter "N".

5.2.11 Set Supervisor/User Password

Either supervisor or user password, or both of them can be set in this option. The differences between them are:

1. **supervisor password:** can enter and change the options of the setup menus.
2. **user password:** just can enter but do not have the right to change the options of the setup menus.

When this function is selected, the following message will appear at the center of the screen for creating a password.

ENTER PASSWORD:

Type the password with eight characters at most, and press <Enter>. The password typed will now clear any previously entered password from CMOS memory. Then, confirm the password by typing the password again and pressing <Enter>. Or, not enter a password and abort the selection by pressing <Esc>.

To disable the password by pressing <Enter> without typing in any password when the message "Enter Password" is showed. Then, message below will appear to confirm that the password has been disabled.

PASSWORD DISABLED.

Once the password is disabled, the system will boot and enter Setup freely.

When a password is enabled, it has to be typed to enter the Setup every time. This prevents any unauthorized person from changing the system configuration.

Additionally when a password is enabled, the BIOS can also set to request a password every time the system reboots. This would prevent unauthorized use of the computer.

The user can determine when the password is required within the BIOS Features Setup Menu and its Security option. If the Security option is set to "System", the password is required during boot up and entry into Setup. If it set as "Setup", prompting will only occur prior to entering Setup.

5.2.12 Save & Exit Setup

This is to determine whether or not to accept the modifications. Typing “Y” quits the setup utility and saves all changes into the CMOS memory. Typing “N” brings back to Setup utility.

Phoenix – Award BIOS CMOS Setup Utility	
▶ Standard CMOS Features	▶ Frequency/Voltage Control
▶ Advanced BIOS Features	Load Fail-Safe Defaults
▶ Advanced Chipset Features	Load Optimized Defaults
▶ Integrated Peripherals	Set Supervisor Password
▶ Power Man	SAVE to CMOS and EXIT (Y/N)? Y
▶ PnP/PCI Con	
▶ PC Health Status	Exit Without Saving
Esc : Quit	↑ ↓ → ← : Select Item
F10 : Save & Exit Setup	
Save Data to CMOS	

5.2.13 Exit Without Saving

Select this option to exit the Setup utility without saving the changes made in this session. Typing “Y” will quit the Setup utility without saving the modifications. Typing “N” will return to Setup utility.

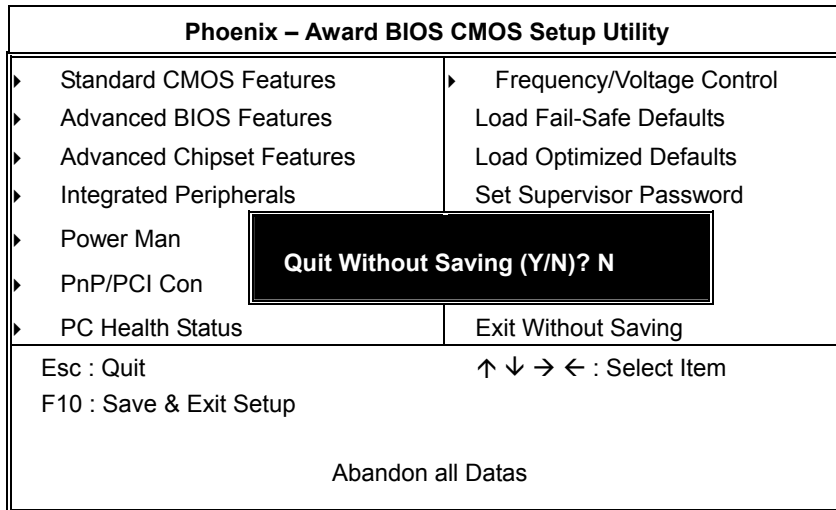

Appendix A

Watchdog Timer

Using the Watchdog Function

The **SBC84600** CPU Board uses version 2.0 of the watchdog timer. This onboard WDT generates either a system reset or non-maskable interrupt (NMI), depending on the settings made on jumper **JP1** of **SBC84600**. Follow the steps below to enable and program the watchdog function of **SBC84600**.

Start

↓

Un-Lock WDT : OUT 120H 0AH ; enter WDT function
OUT 120H 0BH ; enable WDT function

↓

Set multiple (1~4) : OUT 120 0NH ; N=1,2,3 or 4

↓

Set base timer (0~F) : OUT 121 0MH ; M=0,1,2,...F

↓

WDT counting

↓

re-set timer : OUT 121 0MH ; M=0,1,2,...F

↓

IF No re-set timer : WDT time-out, generate RESET or NMI

↓

IF to disable WDT : OUT 120 00H ; Can be disable at any time

M	N			
	1	2	3	4
0	0.5 secs.	5 secs.	50 secs.	100 secs.
1	1 secs.	10 secs.	100 secs.	200 secs.
2	1.5 secs.	15 secs.	150 secs.	300 secs.
3	2 secs.	20 secs.	200 secs.	400 secs.
4	2.5 secs.	25 secs.	250 secs.	500 secs.
5	3 secs.	30 secs.	300 secs.	600 secs.
6	3.5 secs.	35 secs.	350 secs.	700 secs.
7	4 secs.	40 secs.	400 secs.	800 secs.
8	4.5 secs.	45 secs.	450 secs.	900 secs.
9	5 secs.	50 secs.	500 secs.	1000 secs.
A	5.5 secs.	55 secs.	550 secs.	1100 secs.
B	6 secs.	60 secs.	600 secs.	1200 secs.
C	6.5 secs.	65 secs.	650 secs.	1300 secs.
D	7 secs.	70 secs.	700 secs.	1400 secs.
E	7.5 secs.	75 secs.	750 secs.	1500 secs.
F	8 secs.	80 secs.	800 secs.	1600 secs.