

NuIPC
cPCI-3720 series
3U CompactPCI Low Power Pentium-III/Celeron CPU Module
and Rear I/O Transition Module
User's Guide



Recycled Paper

© Copyright 2002 ADLINK Technology Inc.

All Rights Reserved.

Manual Rev. 1.10 April 28, 2003

Part No. 50-15007-100

The information in this document is subject to change without prior notice in order to improve reliability, design and function and does not represent a commitment on the part of the manufacturer.

In no event will the manufacturer be liable for direct, indirect, special, incidental, or consequential damages arising out of the use or inability to use the product or documentation, even if advised of the possibility of such damages.

This document contains proprietary information protected by copyright. All rights are reserved. No part of this manual may be reproduced by any mechanical, electronic, or other means in any form without prior written permission of the manufacturer.

Trademarks

NuIPC is a registered trademark of ADLINK Technology Inc.

Other product names mentioned herein are used for identification purposes only and may be trademarks and/or registered trademarks of their respective companies.

Getting service from ADLINK

Customer Satisfaction is the most important priority for ADLINK Tech Inc. If you need any help or service, please contact us.

ADLINK Technology Inc.			
Web Site	http://www.adlinktech.com		
Sales & Service	Service@adlinktech.com		
Technical Support	NuDAQ + USBDAQ + PXI	nudaq@adlinktech.com	
	Automation	automation@adlinktech.com	
	NuIPC	nuipc@adlinktech.com	
	NuPRO / EBC	nupro@adlinktech.com	
TEL	+886-2-82265877	FAX	+886-2-82265717
Address	9F, No. 166, Jian Yi Road, Chungho City, Taipei, 235 Taiwan.		

Please email or FAX us of your detailed information for a prompt, satisfactory and constant service.

Detailed Company Information			
Company/Organization			
Contact Person			
E-mail Address			
Address			
Country			
TEL		FAX	
Web Site			
Questions			
Product Model			
Environment to Use	OS: Computer Brand: M/B: CPU: Chipset: BIOS: Video Card: Network Interface Card: Other:		
Detail Description			
Suggestions to ADLINK			

Table of Contents

List of Tables.....	iii
How to Use This Guide	iv
Chapter 1 Introduction	1
1.1 Checklist.....	1
1.1.1 Front Board.....	2
1.1.2 Rear Board.....	2
1.2 Description	3
1.3 Features.....	4
1.4 Functional Block and Main Board.....	5
1.4.1 Functional Block Diagram.....	5
1.4.2 Main Board Drawing.....	6
1.4.3 CompactPCI Bus Interface.....	6
1.4.4 PCI-to-PCI Bridge (P2P).....	6
1.4.5 Mobile Intel Pentium III Processor.....	7
1.4.6 Dual Ethernet Interfaces.....	7
1.4.7 IDE Hard Drive.....	7
1.4.8 Serial I/O.....	7
1.4.9 Interrupts	8
1.4.10 DMA	8
1.4.11 Power Ramp Circuitry	8
1.4.12 Watchdog Timer.....	9
1.4.13 IEEE-1284 Parallel Port/Printer Interface.....	9
1.4.14 Universal Serial Bus (USB).....	9
1.4.15 IDE Controller and Floppy Interface Controller.....	9
1.4.16 Keyboard/Mouse Controller.....	10
1.4.17 Software.....	10
1.5 Specifications.....	11
1.5.1 Specifications of the front board (cPCI-3720 series).....	11
1.5.2 Specifications of the rear board cPCI-R3720.....	16
1.5.3 Peripheral Connectivity for Front and Rear Board.....	17
1.6 cPCI-3720 Model Variations Comparison Table.....	18
Chapter 2 Jumpers and Connectors.....	19
2.1 Connectors on the cPCI-3720 & cPCI-R3720.....	20
2.1.1 USB Connectors.....	21
2.1.2 Ethernet (RJ-45) Connector.....	21
2.1.3 PS/2 Mouse/Keyboard Connector.....	22
2.1.4 Serial Port Connections.....	23
2.1.5 CPU Fan Power Connector.....	25
2.1.6 GPIO DB-9 connector (2 nd slot).....	25
2.1.7 Power connector for external FDD (2 nd slot).....	25
2.1.8 CompactPCI Connectors.....	26

Chapter 3 Getting Started	28
3.1 CPU Installation.....	28
3.2 Memory Installation.....	29
3.3 HDD Installation.....	29
3.3.1 <i>HDD Installation for cPCI-3720</i>	29
Chapter 4 Driver Installation	30
4.1 LAN Drivers Installation.....	31
4.1.1 <i>Software and Drivers Support</i>	31
4.1.2 <i>Driver Installation on Windows 2000</i>	31
4.1.3 <i>Driver Installation on Windows 98</i>	32
4.1.4 <i>Driver Installation on Windows NT</i>	33
Chapter 5 Watchdog and Utilities	34
5.1 Watchdog Timer Configuration.....	34
5.1.1 <i>WDT Programming</i>	34
5.1.2 <i>How to Test the WDT</i>	37
5.2 Hardware Doctor Utility.....	37
5.3 Intel Preboot Execution Environment (PXE).....	38
5.4 PICMG 2.1 Hot Swap Support.....	38
Warranty Policy.....	39

List of Tables

Table 1: Tables of Power Consumption under different loading.....	15
Table 2: Peripheral Connectivity for cPCI-3720 and cPCI-R3720.....	17
Table 3: cPCI-3720 Model Variations Comparison Table.....	18
Table 4: Connectors on the cPCI-3720 & cPCI-R3720.....	20
Table 5: USB Connectors Pin definiton.....	21
Table 6: LAN2 Dipswitch setting.....	21
Table 7: Pin Assignment of RJ-45 Ethernet Connector.....	21
Table 8: Amber LED indication in LAN port.....	22
Table 9: Green LED indication in LAN port.....	22
Table 10: PS/2 Keyboard Pin Assignment.....	22
Table 11: Pinout of RJ-45 COM2 Connector.....	23
Table 12: COM2 Serial Port Header (Rear).....	23
Table 13: COM1 Serial Port DB-9 (Rear).....	24
Table 14: COM1 Mode Selection on cPCI-R3720.....	24
Table 15: Pinout of CPU Fan Power Connector.....	25
Table 16: Pinout of GPIO DB-9 Connector.....	25
Table 17: Pinout of Power connector for external FDD.....	25
Table 18: J1 Pin Assignments of cPCI-3720.....	26
Table 19: J2 Pin Assignments of cPCI-3720.....	27

How to Use This Guide

This manual is designed to help you use, setup and maintain a working system with the cPCI-3720 CPU module and its associated rear panel cPCI-R3270. This manual gives the user information on the Specifications, connection types and how to install the different drivers to keep the system running at its optimum level. It is divided into five chapters:

- Chapter 1,** Introduction gives an overview of the product features, applications, and specifications.
- Chapter 2,** Jumpers and Connectors gives an overview of the jumper settings, connector types and its pin assignments.
- Chapter 3,** Getting start will help users to put together a working system, and can help if new peripherals are added to the system
- Chapter 4,** Driver Installation will take the user through step by step to install the software drivers successfully
- Chapter 5,** Watchdog and Utility gives an introduction on how to program the watchdog timer and also on how to install the Hardware Doctor Utility.

Introduction

This manual is designed to provide information on the cPCI-3720 series CPU module and its associated rear I/O transition module cPCI-R3720. The topics covered in this chapter are as follows:

- Checklist
- Descriptions
- Features
- Functional block diagram
- Functional block diagram
- Specifications

1.1 Checklist

The cPCI-3720 series products comply with PICMG 2.0 Rev. 3.0 specifications for 3U CompactPCI form factor. The cPCI-3720 series products support both front panel I/O and rear panel I/O. It is not necessary to use the rear board if the application requires only front panel I/O wiring. The front board (the CPU module) and the rear board (the rear I/O transition module, RTM) are sold separately.

1.1.1 Front Board

Front board is the CPU module. There are several standard versions available for the cPCI-3720 series module (Refer to the model variations comparison table.) Standard versions do not include any RAM or HDD. However, the CPU module may be equipped with different capacities of RAM or HDD on request. Please check your configurations with your dealer and check that your package is complete and contains the items below. If you discover any damaged or missing items, please contact your dealer.

- The cPCI-3720 CPU module (May be equipped with different capacities of RAM or HDD. These items may vary according to the different configuration requested.)
- One 2.5" ATA HDD accessory pack (P/N: 58-00023-000) including special designed 44-wire connection cable and screw kit. (This accessory pack will not be available if 2.5" ATA HDD is pre-mounted by request.)
- Y cable for PS/2 keyboard and mouse connection. (P/N: 30-01016-000)
- This User's Manual
- ADLINK CD

Note: The delivery package of the cPCI-3720 OEM version (non-standard configuration, functionality, customized logo, modified faceplate or package) may vary depending on customized requests.

1.1.2 Rear Board

Rear board is the rear I/O transition module (RTM). Different rear board can provide different I/O function combinations or extensions. The cPCI-3720 series module has one RTM, model number cPCI-R3720. The cPCI-R3720 is designed for standard rear panel I/O for the cPCI-3720. Please check your package is complete and contains the items below. If you discover any damaged or missing items, please contact your dealer.

- The cPCI-R3720 rear I/O transition module
- One 40-wires EIDE cable and one 34-wires FDD cable (P/N: 58-00009-000)
- This User's Manual
- ADLINK CD

Note: The delivery package of cPCI-R3720 OEM version (non-standard configuration, functionality, customized logo, modified faceplate or package) may vary according to the different customized requests.

1.2 Description

The cPCI-3720 is a high-performance, Pentium III processor-based, single board, CompactPCI computer in the Eurocard 3U form factor. It utilizes the Intel Pentium III BGA2 processor to provide extremely high PCI performance and the latest in memory and I/O technology combined with low power requirements.

The cPCI-3720 occupies one or two CompactPCI slot depending on the model purchased. The board is designed as a system master CPU, but can be used in a peripheral slot without communicating over the CompactPCI bus.

The cPCI-3720 is an ideal solution for telecommunications, Internet, and industrial control applications with demanding performance and system reliability requirements.

The "Connector Faceplate" indicates the on-board I/O accessible from the front. The cPCI-3720 can be connected to an optional rear I/O transition board, such as the cPCI-R3720, for increased rear access to I/O.

1.3 Features

- PICMG 2.0 CompactPCI Specification R2.1 Compliant
- PICMG 2.1 R2.0 CompactPCI Hot Swap Specification Compliant
- Standard 3U form factor
- Design for Intel Lower Power BGA2 Pentium-III or Celeron
- 1-slot width version available for low power applications
- Support Pentium-III CPU at 850Mhz (OEM only) and 700Mhz with 256KB on-die L2 cache
- Support Celeron CPU at 400MHz with 128KB on die L2 cache
- One 144-pin SO-DIMM socket supports up to 256MB RAM
- Internal CompactFlash IDE interface
- Supports 7 bus-master PCI devices on CompactPCI bus
- Dual 10/100Mb Ethernet port with Intel 82559 controller, single Ethernet version is also available for big quantity OEM projects
- Built-in one USB port, one serial port, integrated PS/2 type keyboard and mouse connection
- Support remote console via the serial port
- Modularize low profile 2.5 inch HDD mechanism for 2-slot version
- Modularize slim-type FDD mechanism for 3-slot version
- Rear I/O transition module

1.4 Functional Block and Main Board

The following topics provide an overview of the cPCI-3720's main features as shown in the functional block diagram below and also the main board.

1.4.1 Functional Block Diagram

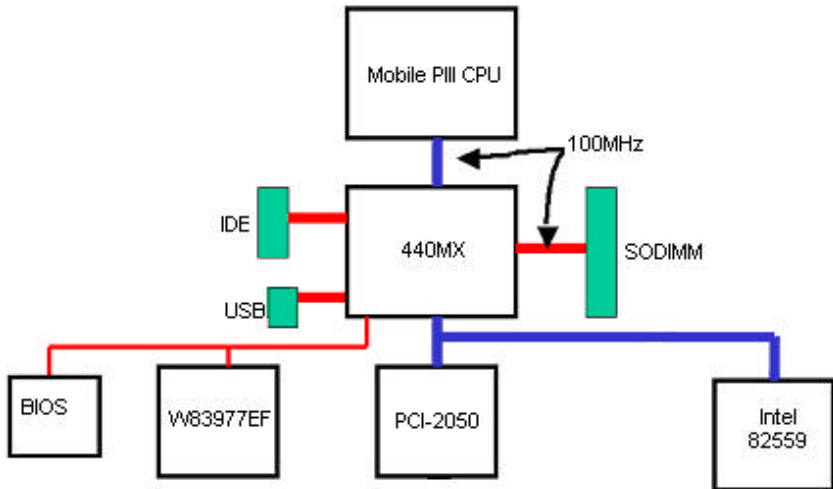

Figure 1: Functional Block Diagram

1.4.2 Main Board Drawing

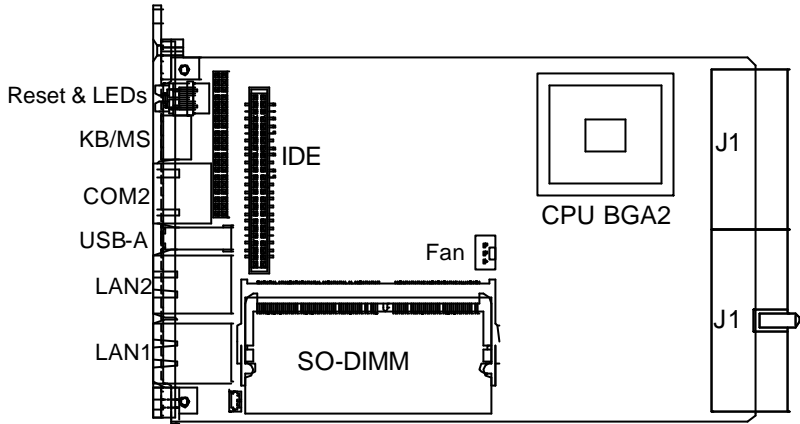

Figure 2: Main Board Drawing

1.4.3 CompactPCI Bus Interface

The cPCI-3720 operates in a 3U CompactPCI system. The CompactPCI standard is electrically identical to the PCI local bus standard but has been enhanced to work in harsh environments and support more peripheral slots. Additionally, when used in a Hot Swap compliant backplane and in accordance with the *CompactPCI Hot Swap Specification, PICMG 2.1, Version 1.0* the cPCI-3720 supports hosting hot swappable peripherals in a powered system. The cPCI-3720 can also function in a standard (non-Hot Swap) CompactPCI system without live insertion and extraction capability.

1.4.4 PCI-to-PCI Bridge (P2P)

The cPCI-3720 features one TI PCI2050 transparent PCI-to-PCI bridge to support the J1 CompactPCI buses. The PCI2050 is compliant with the *PCI Local Bus Specification, Revision 3.0*. Each bridge provides the isolation, arbitration, and clocks for seven PCI peripheral cards without the need for an external bridgeboard.

Special features of the PCI2050 include:

- ✓ 33 MHz PCI bus operation
- ✓ Support for independent primary and secondary PCI clocks
- ✓ 64-bit PCI transparent operation with 32-bit or 64-bit devices from one bus segment to another

1.4.5 Mobile Intel Pentium III Processor

The cPCI-3720 uses the Mobile Intel Pentium III Processor. This 0.18-micron product is a highly integrated assembly containing an Intel Pentium III mobile processor and its immediate system-level support. This mobile version of the Pentium III processor runs at a lower voltage than the desktop version.

The 256 KB on-die transfer L2 cache is integrated with the CPU, eliminating the need for separate components and improving performance. The Mobile Intel Pentium III Processor also operates with a 100 MHz Front Side Bus for faster access to memory and data.

1.4.6 Dual Ethernet Interfaces

The cPCI-3720 provides two 10/100BaseTx Ethernet channels through the Intel 82559 Fast Ethernet Multifunction PCI Controller. The 82559 consist of both the Media Access Controller (MAC) and the physical layer (PHY) interface combined into a single component solution. Two RJ-45 connectors are available on the faceplate. LAN1 is supported on the front I/O only while LAN2 is supported on both front and rear. Although LAN2 is accessible from front and rear I/O, only one port can be utilized at any one time. It is set via Dipswitches.

1.4.7 IDE Hard Drive

The cPCI-3720 includes an on-board 2.5-inch Enhanced IDE hard drive. The hard drive is on the cPCI-3720's primary IDE channel and is assigned "device 0" (master) identity.

1.4.8 Serial I/O

The cPCI-3720 provides support for two 16C550 UARTS serial ports. COM2 is accessible from the faceplate through an RJ-45 connector. COM1 and COM2 are available through the rear I/O of J2

Both serial ports include a complete set of handshaking and modem control signals, maskable interrupt generation, and data transfer rates up to 115.2K Baud. Both COM1 and COM2 serial ports are RS-232 compatible. The cPCI-3720 serial controller resides in the Winbond W83977EF Super I/O device.

1.4.9 Interrupts

Two enhanced interrupt controllers provide the cPCI-3720 with a total of 15 interrupt inputs. Interrupt controller features include support for:

- Level-triggered and edge-triggered inputs
- Individual input masking
- Fixed and rotating priorities

Interrupt sources include:

- Counter/Timers
- Serial I/O
- Keyboard
- Printer Port
- Floppy disk
- IDE interface
- Real-Time Clock
- On-board PCI devices

Enhanced capabilities include the ability to configure each interrupt level for active high going edge or active low-level inputs. The cPCI-3720's interrupt controllers reside in the Intel 440MX

1.4.10 DMA

An enhanced seven channel DMA controller is provided on the cPCI-3720 for use by the onboard peripherals. The cPCI-3720's DMA controllers reside in the Intel 440MX device.

1.4.11 Power Ramp Circuitry

The cPCI-3720 features a power controller with power ramp circuitry to allow the board's voltages to be ramped in a controlled fashion. The power ramp circuitry eliminates any large voltage or current spikes caused by hot swapping boards. This controlled ramping is a requirement of the *CompactPCI Hot Swap specification, PICMG 2.1, Version 1.0*. The cPCI-3720's power controller unconditionally resets the board when it detects that the 3.3V, 5V, and 12V supplies are below an acceptable operating limit. These limits are defined as 4.75V (5V supply), 3.0V (3.3V supply), and 10.0V (+12V supply).

1.4.12 Watchdog Timer

The watchdog timer optionally monitors system operation and can be programmed for different timeout periods (from 1 seconds to 255 seconds or 1 minute to 255 minutes). Failure to strobe the watchdog timer within the programmed time period may result a reset request. A register bit can be enabled to indicate if the watchdog timer caused the reset event. This watchdog timer register is cleared on power-up, enabling system software to take appropriate action if the watchdog generated the reboot.

1.4.13 IEEE-1284 Parallel Port/Printer Interface

The parallel I/O interface signals are routed to the J2 I/O connector on the board. This port supports the full IEEE-1284 specifications and provides the basic printer interface.

Firmware will initialize the parallel port as LPT1 with ISA I/O base address of 378h. This default configuration also assigns the parallel port to IRQ7. The printer interface mode (Normal, Extended, EPP, or ECP) is selectable through the BIOS SETUP utility with the Winbond W83977EF Super I/O device managing the cPCI-3720's parallel port.

1.4.14 Universal Serial Bus (USB)

The Universal Serial Bus (USB) provides a common interface to slower-speed peripherals. Functions such as keyboard, serial ports, printer port, and mouse ports can be consolidated into USB, simplifying the cabling requirements of computers. The cPCI-3720 provides two USB ports. USB-A is on the front faceplate while USB-B is routed to the J2 connector on the rear I/O and is controlled by the Intel 440MX device.

1.4.15 IDE Controller and Floppy Interface Controller

The cPCI-3720 includes an IDE Controller (in the 440MX) and a Floppy Disk Controller (in the W83977EF). The IDE Controller provides support for internal or external IDE drives. Signals are available at the IDE connector and are routed to a 44-pin header. The FDD Controller provides support for an external FDD drives. Signals are available at the FDD connector and are routed to a 34-pin header. The FDD connector is available on the front faceplate only on the 2-slot version.

1.4.16 Keyboard/Mouse Controller

The cPCI-3720 includes an on-board PC/AT keyboard and mouse controller. The keyboard/mouse signals are available through the PS/2 circular DIN on the front panel. Both the keyboard and mouse can be connected at the same time using ADLINK's Y cable. The cPCI-3720's keyboard/mouse controller resides in the Winbond W83977EF Super I/O device

1.4.17 Software

The cPCI-3720 includes the ADLINK NuIPC Embedded BIOS loaded in on-board flash. The BIOS is user-configurable to boot an operating system from local flash memory, a fixed or floppy drive, or over a network.

The cPCI-3720 is compatible with all major PC operating systems. ADLINK provides support, which may include additional drivers for ADLINK peripherals. Software device drivers for the cPCI-3720 may be found in the ADLINK CD.

1.5 Specifications

1.5.1 Specifications of the front board (cPCI-3720 series)

General CompactPCI Features

- PICMG 2.0 CompactPCI Specification R.3.0 Compliant
- PICMG 2.1 CompactPCI Hot-swap specification R2.0 compliant

Form Factor

- Standard 3U CompactPCI (board size: 100 mm x 160 mm)
- cPCI-3720A Series: 1-slot (4TE/HP) wide
- cPCI-3720B Series: 2-slot (8TE/HP) wide, with HDD housing
- A slim-type FDD kit support 3-slot (12TE/HP) wide version

CPU/Cache

- Intel BGA2 Low Power Pentium III with 256KB on-die L2 cache at full-core
- Intel BGA2 Mobile Celeron with 128KB on-die L2 cache at full core speed
- Front side bus frequency: 100MHz

Chipset

- Intel 440MX

BIOS: Award PnP BIOS

- Award PnP BIOS with 2Mb (256KB) Flash ROM
- BIOS write protection, provide anti-virus capability
- Customized power-on screen (for OEM projects)
- DMI BIOS Support: Desktop Management Interface (DMI) allows users to download system hardware-level information such as CPU type, CPU speed, internal/external frequencies and memory size.
- Supports Intel pre-boot execution environment (PXE) for remote boot
- Remote console support

Note: Due to the BIOS segment limitation; enabling the remote console function may occupy the same memory space as other ROM-mapping add-on or boot-up devices such as Pre-boot Agent of Ethernet Boot ROM, SCSI Boot ROM or add-on EIDE Boot ROM. It is recommended you enable only one ROM-mapping add-on or boot-up device when enabling the remote console function.

Host Memory

- One 144-pin SO-DIMM socket, support maximum 256MB un-buffered SDRAM module

IDE Ports

- Bus Master IDE controller: One 44-pin EIDE interfaces for up to two IDE devices
- With mezzanine card, provide one CompactFlash socket and 44-pin IDE connector
- Support CompactFlash storage disk from 8MB up to 512MB
- For 2-slot version, a mechanism to support a built-in 2.5" ATA HDD

Note: cPCI-3720 2slot version supports one 2.5" ATA HDD and one CompactFlash socket.

On Board Super I/O

- Winbond W83977EF
- One high-speed bi-directional SPP/EPP/ECP parallel port on J2 rear I/O
- One FDD interface, support slim floppy drive
- Two 16C550 UARTs compatible COM ports, COM1 is on the rear I/O, COM2 is designed for using on both front faceplate (via RJ-45 connector) and rear I/O
- One integrated keyboard and mouse connector

USB Interface

- Supports up to two USB ports, one port on faceplate of CPU module, and one on the rear I/O transition module
- USB Specification Rev. 1.1 compliant
- 500mA over-current protection

Watch-dog Timer

- Programmable I/O port 3F0h and 3F1h to configure watchdog timer, programmable timer 1~255 seconds or 1~255 minutes
- Watchdog timer time out will generate interrupt to NMI or RESET, which is BIOS selectable.
- Bundled easy-programming library for DOS and Windows 98/NT/2000

Hardware Monitoring

- Winbond W83L784R, monitoring CPU temperature, system temperature and DC Voltages

On-board Ethernet supporting

- Two Ethernet ports: LAN 1 support front I/O. LAN 2 support both front and rear I/O. DIP switch selectable
- Intel 82559 high performance Ethernet controller
- IEEE 802.3 10Base-T/100Base-TX compatible
- IEEE 802.3u Auto-negotiation support
- IEEE 802.3x 100Base-TX flow control support
- Supports Intel pre-boot execution environment (PXE) for remote boot of Windows NT/2000

OS Compatibility

- Windows 95/98, Windows NT 4.0, Windows 2000, VxWorks

Flash Disk Supporting

- Support Flash2000™ (from 32MB to 512MB) flash-storage drive on 2.5" IDE interface.
- Support CompactFlash flash-storage drive (from 32MB to 512MB)

PCI Bus Bridge

- Supports up to 7 PCI bus mastering devices on CompactPCI bus for peripheral slots

Front Panel LEDs and switch

- Active LED (Green), HDD LED (Red), WDT LED (Amber), General Purpose LED (Blue)
- Flush tact switch for system reset

Environment

- Operating temperature: 0 to 55°C ^(Note)
- Storage temperature: -20 to 80°C
- Humidity: 5% to 95% non-condensed
- Shock: 15G peak-to-peak, 11ms duration, non-operation
- Vibration
 - ✓ Non-operation: 1.88Grms, 5-500Hz, each axis
 - ✓ Operation: 0.5Grms, 5-500Hz, each axis, with 2.5" HDD

Note: The vibration limitation of operation is limited by the 2.5" ATA HDD. If customer wishes to deploy the cPCI-3720 into high vibration environment, we suggest user to use a Flash2000 Flash Disk (FFD series) or CompactFlash Card to replace the 2.5" ATA HDD.

Safety Certificate and Test

- CE, FCC Class B
- HALT (temperature and vibration stress)

Power Consumption

The tables below show the power consumption of the cPCI-3720 for different loadings.

Hardware Environment:

- cPCI-3720 A3 SBC (PIII-700, 1.35V)
- cPCI-8217 VGA card (Power Consumption: 0.915W)
- One 64MB Compact Flash (PQI)
- One 10GB 2.5" HDD (Fujitsu MHM2100AT)
- 256MB SDRAM (Transcend)
- 2 on-board ethernet connect to network

Software Environment:

- OS: WinNT 4.0
- HCT 9.5
- Burn-in Test (CPU, RAM, HDD and Dual-ethernet test running)

MAX Power consumption

(MAX current. In WinNT with both HCT & Burn-in Test are running)

CPU	Voltage	Current (A)	Watt
P-III 700 1.35V	3.3V	2.48	8.184
	5V	2.80	14
Total Watt = 8.184 + 14 - 0.915 = 21.269			

Average Power Consumption

(Mean current. In WinNT with both HCT & Burn-in Test are running)

CPU	Voltage	Current (A)	Watt
P-III 700 1.35V	3.3V	1.465	4.8345
	5V	2.587	12.935
Total Watt = 4.8345 + 12.935 - 0.915 = 16.8545			

Light Load Power consumption

(Mean current. In WinNT with nothing running)

CPU	Voltage	Current (A)	Watt
P-III 700 1.35V	3.3V	0.919	3.0327
	5V	1.268	6.34
Total Watt = 3.0327 + 6.34 - 0.915 = 8.4577			

Table 1: Tables of Power Consumption under different loading

Note: The above values are the measured power consumption of the cPCI-3720 with CPU, RAM HDD and dual-ethernet test running; the CPU is running at 100% loading with HCT and burn-in test programs under WinNT unless otherwise specified.

1.5.2 Specifications of the rear board cPCI-R3720

General CompactPCI Features

- PICMG 2.0 CompactPCI Specification R3.0 compliant
- IEEE 1101.11 rear transition module mechanism compliant

Form Factor

- Form factor: Standard 3U CompactPCI Rear I/O with cPCI-J2 connector, 4HP wide (1-slot).

Multi-I/O Ports

- Two serial ports: COM1 is RS-232/422/485/485+ selectable and is routed to a DB-9 connector on faceplate. COM2 is RS-232 and is routed to one on-board 10-pin header..
- One PS/2 connector (include keyboard and mouse)
- One LPT connector (on-board 26-pin header)

USB Interface

- One USB type B connector on rear faceplate

Ethernet Ports

- One RJ-45 Ethernet ports on rear faceplate, which support 10BASE-T or 100BASE-TX Ethernet.

Driver Installation

- No extra driver necessary for using cPCI-R3720

 COM2, Keyboard, Mouse, and LAN ports support wiring on front and rear I/O. However, do not connect devices on the front and rear I/O for the one I/O function at the same time. It may damage the I/O port or the system module and the warranty will be void.

1.5.3 Peripheral Connectivity for Front and Rear Board

Peripheral Connectivity for cPCI-3720 and cPCI-R3720 I/O	Front Faceplate	On-board Board	Rear I/O Connector
Serial Port (COM1)	---	---	J2
Serial Port (COM2)	Y(RJ-45)	---	J2
Parallel Port	---	---	J2
Keyboard & Mouse	Y(PS/2)	---	
Floppy	Y (2-slot version only)	Y (slim type, 2-slot version only)	---
Ultra DMA 33 IDE 1	---	Y	---
CompactFlash	---	Y(Mezzanine)	---
USB A	Y(USB)	---	---
USB B	---	---	J2
10/100Mb Ethernet Port #1	Y(RJ-45)	---	---
10/100Mb Ethernet Port #2	Y(RJ-45)	---	J2
LEDs	Y	---	---
Reset button	Y	---	---

Table 2: Peripheral Connectivity for cPCI-3720 and cPCI-R3720

-
- Please use the proper rear I/O transition module to enable the functions (I/O interfaces) on the rear side. The board or system will be damaged if the incorrect rear I/O transition module is used. Please refer to Chapter 2 for Ethernet front I/O or rear I/O connecting selection switch setting and refer to Chapter 3 for the usage notice of rear I/O transition module.
 - cPCI-3720 supports LAN2 at both front and rear I/O. Front and rear I/O cannot be accessed simultaneously and selected by HW switch S2 and S3 on backside. The Ethernet port will be assigned a unique static MAC Address. The board's Ethernet Addresses are displayed on a label attached to the board. LEDs drive signals for Ethernet link status and activity are routed to the same connectors. The BIOS have a selection in the CMOS setup to disable the on-board LAN port.
-

1.6 cPCI-3720 Model Variations Comparison Table

(Front Board only)

Model	cPCI-3720A/ P72	cPCI-3720A/ C42	cPCI-3720B/ P72	cPCI-3720B/ C42
Processor	Pentium-III 700MHz	Celeron 400Mhz	Pentium-III 700MHz	Celeron 400Mhz
Processor FSB	100 MHz	100 MHz	100MHZ	100MHZ
Chipset	Intel 440MX	Intel 440MX	Intel 440MX	Intel 440MX
Memory Size	Up to 256MB	Up to 256MB	Up to 256MB	Up to 256MB
Memory Type	PC-100 SDRAM in 144-pin SO-DIMM	PC-100 SDRAM in 144-pin SO-DIMM	PC-100 SDRAM in 144-pin SO-DIMM	PC-100 SDRAM in 144-pin SO-DIMM
Serial Port	COM2 thru RJ-45	COM2 thru RJ-45	COM2 thru RJ-45	COM2 thru RJ-45
USB	1	1	1	1
Ethernet Port	2 Ports (Intel 82559)	2 Ports (Intel 82559)	2 Ports (Intel 82559)	2 Ports (Intel 82559)
Dimension	3U x 4TE/HP (1 slot wide)	3U x 4TE/HP (1 slot wide)	3U x 8TE/HP (2 slot wide)	3U x 8TE/HP (2 slot wide)
HHD Mezzanine mechanism	No	No	Yes	Yes
CompactFlash Mezzanine Card	Yes	Yes	Yes	Yes

Table 3: cPCI-3720 Model Variations Comparison Table

2

Jumpers and Connectors

This chapter provides a detailed description and pin-out for each connector and Jumper. LED indicators are also introduced. The topics covered are:

- Jumpers, Connectors and LED indicators on the cPCI-3720
- Jumpers, Connectors and LED indicators on the cPCI-R3720

2.1 Connectors on the cPCI-3720 & cPCI-R3720

The following subsections specify the pin assignments for the connectors on cPCI-3720 & cPCI-R3720.

Board	Connector	Description
cPCI-3720	cPCI J1	PCI Bus
	cPCI J2	PCI Bus, COMs, USBs, LAN1, LPT
	LAN1 RJ-45	With 1 transformer and two LEDs built-in
	LAN2 RJ-45	With 1 transformer and two LEDs built-in
	COM2 RJ-45	COM Port
	USB-A	USB
	IDE	Two 44pin IDE connector
	KB/MS	PS/2 connector
	Floppy	Slim type 26pin floppy connector and standard 34-pin connector on faceplate (2-slot version only)
	Reset Button	Reset System
	CompactFlash	CompactFlash connector
40pin board-to-board	2 nd slot connector	
Fan	CPU Fan connector	
cPCI-R3720	cPCI J2	PCI Bus, COMs, USB, LAN1, LPT, KB/MS
	LPT (on-board 26-pin header)	Printer connector
	LAN2 RJ-45	82559 LAN without LEDs
	COM1 (on-board 10-pin header)	COM Port
	COM2 DB-9	COM Port
	USB-B	USB

Table 4: Connectors on the cPCI-3720 & cPCI-R3720

2.1.1 USB Connectors

The cPCI-3720 supports 2 USB serial ports, USB-A is on both front and rear I/O, USB-B is on the rear I/O only. USB allows for the easy addition of peripherals such as mouse, keyboard, speakers, etc. Transfer rates up to 12Mb/s are supported. The cPCI-3720 will provide the standard 0.5A at 5V to the peripherals.



Signal Name	Pin #
Vcc	1
USB-	2
USB+	3
Ground	4

Table 5: USB Connectors Pin definition

2.1.2 Ethernet (RJ-45) Connector

The cPCI-3720 provides two 10/100Mbps Ethernet interfaces via the Intel 82559 chip. LAN 1 is supported on the front I/O only. LAN 2 is supported on both the front and rear I/O. LAN2 on the front and rear I/O cannot be accessed simultaneously and is enabled/disabled by dipswitches on the board. The board's Ethernet Addresses are displayed on a label attached to the board. LEDs drive signals for Ethernet link status and activity are routed to the same connectors. The BIOS has a selection in the CMOS setup to disable the on-board LAN ports. Please refer to the table below on how to set the dipswitches for LAN2 front or rear operation

	S2 (1-4)	S3 (1-4)
Front LAN2	All ON	All OFF
Rear LAN2	All OFF	All ON

Table 6: LAN2 Dipswitch setting

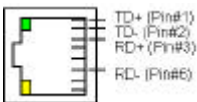

Pin	Signal	Function
1	TDP	Transmit Data (+)
2	TDN	Transmit Data (-)
3	RDP	Receive Data (+)
4	LANCT1	Termination
5	LANCT2	Termination
6	RDN	Receive Data (-)
7	NC	No Connect
8	GND	Ground

Table 7: Pin Assignment of RJ-45 Ethernet Connector

Please refer to the table below for the definition for each color indicator on the LED on the RJ-45 LAN ports

Amber LED 10/100Mbps Status	Description
OFF	10Mbps transfer rate
ON	100Mbps transfer rate

Table 8: Amber LED indication in LAN port

Green LED Link/Activity Status	Description
OFF	No link
ON	Connecting
Blinking	Active/Data transferring

Table 9: Green LED indication in LAN port

2.1.3 PS/2 Mouse/Keyboard Connector

One 6-pin circular DIN connector (PS/2) is available on the front panel of the cPCI-3720 for keyboard and the mouse connections. Both keyboard and mouse can be connected together using ADLINK's Y cable. Note that without the Y-cable, only the keyboard can be connected.

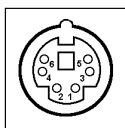

Pin #	Signal	Function
1	KBDATA	Keyboard data
2	MSDATA	Mouse data
3	GND	GND
4	+5V	Power
5	KBCLK	Keyboard clock
6	MSCLK	Mouse clock

Table 10: PS/2 Keyboard Pin Assignment

2.1.4 Serial Port Connections

Two serial ports are supported on the cPCI-3720. COM1 is on the rear I/O only through J2 and COM2 is available on both the front faceplate (via RJ-45 connector) and rear I/O. Both ports are configured as DTE. Firmware will initialize the two serial ports as COM1 and COM2 with ISA I/O base addresses of 3F8h and 2F8h respectively. This default configuration also assigns COM1 to IRQ4 and COM2 to IRQ3.

COM2

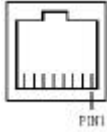

Pin #	Signal Name
1	DCD, Data carrier detect
2	RTS, Request to send
3	DSR, Data set ready
4	TXD, Transmit data
5	RXD, Receive data
6	GND, ground
7	CTS, Clear to send
8	DTR, Data terminal ready

Table 11: Pinout of RJ-45 COM2 Connector

COM2 Serial Port Header (Rear)

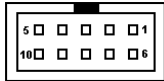

Pin	Signal	Function
P1	DCD2#	Data Carrier Detect
P2	DSR2#	Data Set Ready
P3	RXD2	Receive Data
P4	RTS2	Request to Send
P5	TXD2	Transmit Data
P6	CTS2#	Clear to Send
P7	DTR2#	Data Terminal Ready
P8	RI2#	Ring Indicate
P9	GND	Ground
P10	DCD1#	No Connect

Table 12: COM2 Serial Port Header (Rear)

COM1 Serial Port DB-9 (Rear)

Note that COM1 is RS232/RS422/RS485/RS585+ selectable, please see table 14 on setting the correct jumpers depending on the mode of operation required for COM1.

Pin #	Signals
1	Data Carrier Detect
2	Data Set Ready
3	Receive Data
4	Request to Send
5	Transmit Data
6	Clear to Send
7	Data Terminal Ready
8	Ring Indicate
9	Ground

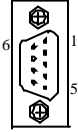

Table 13: COM1 Serial Port DB-9 (Rear)

JP1~JP4 COM1 Mode Selection on cPCI-R3720

Type	JP1	JP2	JP3	JP4
RS-232 (Default)	Unused			
RS-422				
RS-485				
RS-485+				

Table 14: COM1 Mode Selection on cPCI-R3720

2.1.5 CPU Fan Power Connector



Pin	Signal Name
1	Ground
2	+12V
3	Rotation

Table 15: Pinout of CPU Fan Power Connector

2.1.6 GPIO DB-9 connector (2nd slot)

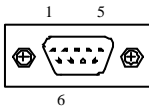

Pin	Signal
P1	Photo MOS+
P2	Photo MOS-
P3	GPIO1
P4	GPIO2
P5	GND
P6	N/C
P7	N/C
P8	GPIO3
P9	GPIO4

Table 16: Pinout of GPIO DB-9 Connector

2.1.7 Power connector for external FDD (2nd slot)

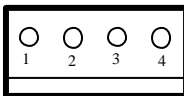

Pin	Signal
P1	+5V
P2	GND
P3	GND
P4	+12V

Table 17: Pinout of Power connector for external FDD

2.1.8 CompactPCI Connectors

J1 Pin Assignments of cPCI-3720

Pin	A	B	C	D	E	F
J1-25	+5V	REQ64#	ENUM#	+3.3V	+5V	GND
J1-24	AD[1]	+5V	NC	AD[0]	ACK64#	GND
J1-23	+3.3V	AD[4]	AD[3]	+5V	AD[2]	GND
J1-22	AD[7]	GND	+3.3V	AD[6]	AD[5]	GND
J1-21	+3.3V	AD[9]	AD[8]	GND	C/BE[0]#	GND
J1-20	AD[12]	GND	NC	AD[11]	AD[10]	GND
J1-19	+3.3V	AD[15]	AD[14]	GND	AD[13]	GND
J1-18	SERR#	GND	+3.3V	PAR	C/BE[1]#	GND
J1-17	+3.3V	SMSCL	SMSDA	GND	PERR#	GND
J1-16	DEVSEL#	GND	NC	STOP#	LOCK#	GND
J1-15	+3.3V	FRAME#	IRDY#	GND	TRDY#	GND
J1-12~14	Keying Area					
J1-11	AD[18]	AD[17]	AD[16]	GND	C/BE[2]#	GND
J1-10	AD[21]	GND	+3.3V	AD[20]	AD[19]	GND
J1-9	C/BE[3]#	GND	AD[23]	GND	AD[22]	GND
J1-8	AD[26]	GND	NC	AD[25]	AD[24]	GND
J1-7	AD[30]	AD[29]	AD[28]	GND	AD[27]	GND
J1-6	REQ7#	GND	+3.3V	CLK7	AD[31]	GND
J1-5	NC	NC	PCIRST#	GND	GNT7#	GND
J1-4	NC	NC	NC	NC	SIRQ	GND
J1-3	INTA#	INTB#	INTC#	+5V	INTD#	GND
J1-2	TCK	+5V	TMS	TDO	TDI	GND
J1-1	+5V	-12V	TRST#	+12V	+5V	GND
Pin	A	B	C	D	E	F

Table 18: J1 Pin Assignments of cPCI-3720

J2 Pin Assignments of cPCI-3720 (support 32-bit system slot)

Pin	A	B	C	D	E	F
J2-22	NC	NC	NC	NC	NC	GND
J2-21	CLK6	GND	ETH_TxF+	ETH_TxF-	ETH_R45	GND
J2-20	CLK5	GND	KBCLK	GND	ETH_R78	GND
J2-19	GND	GND	NC	ETH_RxF+	ETH_RxF-	GND
J2-18	LPT-STP	LPT-PE	KBDATA	NC	CLK33	GND
J2-17	LPT-AFD	GND	PRST#	REQ6#	GNT6#	GND
J2-16	LPT-D0	LPT-ACK	NC	GND	MSCLK	GND
J2-15	LPT-ERR	GND	NC	REQ5#	GNT5#	GND
J2-14	LPT-D1	LPT-SLCT	USB +5V	GND	RI1	GND
J2-13	LPT-INIT	GND	NC	DTR1 #2	CTS1	GND
J2-12	LPT-D2	MSDATA	USB2-DATA+# 2	GND	TxD1	GND
J2-11	LPT-SLIN	GND	NC	RTS1 #2	RxD1	GND
J2-10	LPT-D3	VCCKBMS	USB2-DATA-# 2	GND	DSR1	GND
J2-9	LPT-D4	GND	NC	DCD1 #2	RI2	GND
J2-8	LPT-D5	NC	NC	GND	DTR2	GND
J2-7	LPT-BUS	GND	NC	CTS2 #2	TxD2	GND
J2-6	LPT-D6	+5V	+5V	GND	RTS2	GND
J2-5	LPT-D7	GND	NC	RxD2 #2	DSR2	GND
J2-4	NC	USB GND	NC	GND	DCD2	GND
J2-3	CLK4	GND	GNT3#	REQ4#	GNT4#	GND
J2-2	CLK2	CLK3	SYSEN#	GNT2#	REQ3#	GND
J2-1	CLK1	GND	REQ1#	GNT1#	REQ2#	GND
Pin	A	B	C	D	E	F

Table 19: J2 Pin Assignments of cPCI-3720

3

Getting Started

This chapter provides information on how to install necessary components on the cPCI-3720 in order to set up a workable system. The topics covered are:

- CPU Installation
- Memory Installation
- CF Installation
- HDD Installation
- Device Connection for OS Installation
- Notice for Rear I/O Connection

3.1 CPU Installation

The cPCI-3720 CPU module supports Intel BGA2 Low Power Pentium-III/Celeron processors with a 100 MHz front side bus (FSB) frequency.

The CPU on cPCI-3720 series products is pre-mounted on the PCB (printed circuit board) in the factory. Users do not need to install any CPU. The heatsink is also pre-mounted in the factory.

-
-  Please do not try to replace the CPU on field or remove the heatsink. It will cause board defect and the warranty will be invalid.
-

3.2 Memory Installation

The cPCI-3720 CPU module supports one PC-100 144-pin SO-DIMM socket for a maximum total memory size of 256MB. The memory type must be 3.3V SDRAM. The memory module can come in size of 32MB, 64MB, 128MB or 256MB PC-100 144-pin SO-DIMM.

ADLINK's factory also provides the pre-mounting memory service for volume orders of OEM project on request. Please contact your dealer or ADLINK's sales representatives.

Note: Ensure that the RAM module is firmly socked in the SO-DIMM socket and is not over the height limitation, otherwise the components may be damaged when the CPU module is inserting into the chassis.

3.3 HDD Installation

The cPCI-3720 2-slot version is equipped with a slim -type HDD Mezzanine mechanism where a 2.5" HDD can be seated. If users wish to install a 2.5" ATA HDD for larger storage capacity, users can purchase off-the-shelf 2.5" ATA HDD from the market. Due to the space limitation and for better ventilation consideration, low profile (or slim type) 2.5" ATA HDD that is no thicker than 9.5mm is allowed.

3.3.1 HDD Installation for cPCI-3720

- Find the HDD accessory pack inside your original package. (User purchasing the OEM model, non-standard, customized or special configuration model, the HDD accessory package may not be included as part of the packaging. Please contact with ADLINK dealer or sales representative to purchase this accessory pack P/N: 58-00023-000.)
- Check the master/slave setting of your 2.5" ATA HDD
- Screw four copper hexagonal stand-offs on the bottom side of 2.5" ATA HDD
- Mount the HDD using four M3 screws on to the HDD mezzanine mechanism
- Connect the HDD to the IDE connector on the cPCI-3720 with the ribbon cable that is included in the HDD accessory pack
- Check pin1 of the IDE connector, cable and HDD are all matched
- Re-check the ribbon cable, HDD and HDD supporting stand-off are all fixed & connected

Driver Installation

To install the drivers and utility for the cPCI-3720, please refer to the installation information from this chapter. This manual provides basic installation information, however, for more detailed installation information for non-Windows OS, please refer to the extensive information inside the ADLINK CD. Drivers are stored in the following directories:

Chipset driver	\\CHIPDR\\Chipset440MX
LAN relative driver	\\CHIPDR\\LAN\\100PDISK
Watchdog relative library	\\CHIPDR\\WDT
Hardware Doctor Utility	\\Utility\\HWDoctor\\W83L784R

In this user's manual, the Bus-mastering IDE driver installation is not described because most Windows based OS will install those drivers automatically.

Since Windows NT is not a plug-and-play OS, some tips for installing Windows NT drivers are outlined here:

1. We suggest installing the LAN driver before installing any service pack.
2. If your NT booting procedure boots with a warning message, please check the Event Viewer to check the source generating the warning message. If strange phenomena's occur and it can't be solved, we recommend you re-install the Windows NT service pack then install the drivers in different sequences.

4.1 LAN Drivers Installation

This section describes the LAN driver installation for the onboard Ethernet controller Intel 82559. The Intel 82559 is a 32-bit 10/100Mbps Ethernet controller for PCI local bus-compliant PCs. It supports the bus mastering architecture, and Auto-negotiation feature which makes it possible to combine a common Ethernet cable— an RJ-45 connector with twisted-pairs cabling that can be used for both 10Mbps and 100Mbps connection.

The relative drivers are under the following ADLINK CD directory: X:\CHIPDRV\LAN\100PDISK, where X: is the location of the CD-ROM drive.

4.1.1 Software and Drivers Support

The 82559 drivers support the following OS or platforms:

- Windows 98, Windows 95, Windows 2000, Windows NT
- Novell Netware, DOS Setup for Novell NetWare DOS
- UNIX, OS2, Linux

All the above drivers are included in the ADLINK CD. In the following section, we will describe the driver installation for Windows 98, Windows 2000, and Windows NT. For the driver installation of the other OS, please refer the readme file inside the CD.

4.1.2 Driver Installation on Windows 2000

Windows 2000 will attempt to install a LAN driver automatically. We recommend you manually install the most updated LAN driver, which is shipped with ADLINK CD to guarantee compatibility. After installing Windows 2000, please update the new driver by following these procedures.

1. Boot Windows 2000, Click **Start**. Select **Settings** then double-click the **Control Panel**.
2. Double-click **System** icon, click **Hardware** tab, click **Device Manager** button.
3. Double-click **Network Adapters** entry, Double-click the Intel 8255x-based PCI Ethernet Adapter (10/100) entry.
4. Click **Driver** tab and then click **Update Driver...** button.
5. An Update Device Driver Wizard windows will appear, click **Next>**.
6. Select **Display a list of ...** and click **Next>**. The next window may show a list of hardware models.
7. Insert the CD and click **Have Disk**.

8. Browse the Intel 82559 driver in the following path: **X:\CHIPDRV\LAN\100PDISK**, highlight **oemsetup.inf**, and click **Open**, then click **OK**.
9. Highlight model: **Intel 8255x- based PCI Ethernet Adapter (10/100)**, then click **NEXT>**. An Update Driver Warning window may pop up, click **Yes** to continue.
10. Click **NEXT>** button, then the Wizard summary window appears.
11. Click **Finish** button, then click **CLOSE** button.

4.1.3 Driver Installation on Windows 98

Windows 98 will install the LAN driver automatically. We recommend you manually updated the LAN driver, which comes with the ADLINK CD to guarantee compatibility. After installing Windows 98, please update the new driver by following these procedures.

1. Boot Windows 98, Click **Start**. Select **Settings** then double-click the **Control Panel**.
2. Double-click on the **System** icon, click on the **Device Manager** tab.
3. Double-click on the **Network Adapters** entry,select the **Intel 8255x-based PCI Ethernet Adapter (10/100)** entry. Click the **Properties** button.
4. Click on the **Driver** button, then click **Update Driver...** button.
5. **Update Device Driver Wizard** will pop up, click **NEXT**.
6. Select **Display a list of ...** and click **NEXT**. The next window allows the user to specify a specific path. Insert the CD and click **Have Disk**.
7. Browse the Intel 82559 driver in the following path: **X:\CHIPDRV\LAN\100PDISK**, highlight **net82557.inf**, click **OK**. The Update Wizard displays a message that a new driver as been found. Click OK again to update the driver. Note: Windows 98 may ask you to insert the original Windows 98 CD to install the LAN protocols.
8. Click **NEXT** button, then the Wizard summary window appears.
9. Click **Finish** button, then restart the computer to activate the new driver.

4.1.4 Driver Installation on Windows NT

Before install the LAN driver on Windows NT, please copy the LAN driver in the CD to a floppy diskette. You have to put a new disk into drive A, then type the following batch command under the DOS environment to copy the relative NT drivers.

X:\CHIPDRV\LAN\100PDISK\Makedisk\Makedisk NT, where X is the CD-ROM drive.

Windows NT may ask to installs a LAN driver from its own library of drivers. We recommend you manually updated the LAN driver, which comes with the ADLINK CD to guarantee the compatibility. After installing Windows NT, please update the new driver by the following procedures.

1. In the **Control Panel**, double-click on the **Network** icon, a Network Configuration window will pop-up. Click **Yes**.
2. On the Network Setup Wizard, click **Next>**, click **Select From List...** button.
3. Insert LAN driver floppy diskette into A drive and click **Have Disk**.
4. In the dialog box of Insert Disk window, type in **A:** then Click **OK**.
5. A Select OEM Option window pop up, click **OK**, then click **Next>**.
6. Select necessary Network Protocols, click **Next>**.
7. Select necessary Network Services, click **Next>**.
8. Click **Next>** until Window NT Setup dialog box pops up. Type in **D:\V386** (drive D:\ is assumed to be where WinNT resides) in the dialog box, then insert the original Windows NT CD, click **Continue**.
9. Then click **OK** when the setup completed.
10. Reboot the computer.

Watchdog and Utilities

This chapter takes you through how to configure the watchdog timer and a brief introduction to the utilities that are available to the cPCI-3720.

5.1 Watchdog Timer Configuration

The cPCI-3720 implements a watchdog timer embedded in the W83977EF. It contains a one-second/minute resolution down counter (in CRF2 of logical device 8 of the W83977EF) and two Watchdog control registers (CRF3 and CRF4 of logical device 8). Once you give a value to the WDT, the timer begins to count down.

Any movement of the keyboard, mouse or a software call, the value will be reloaded back into the WDT. The Watchdog output is connected to “reset”. When the system hangs up without software re-trigger, the system will be reset.

So basically this is a watchdog timer that has a 1 second granularity up to 255 seconds or a 1-minute granularity up to 255 minutes. The keyboard and mouse will only reset the WDT if Bit 2 and 1 of CRF3 are set.

5.1.1 WDT Programming

To configure the registers, the following sequence should be followed:

1. Writing 87h to location 3F0h twice to enter into the extended function mode.
2. Configure the registers to set up WDT.
3. Writing 0AAh to location 3F0h to exit the extended function mode.

The example shown below will reset the system after 15 seconds. Both keyboard and mouse interrupts will reload WDT from CRF3.

BEGIN:

```

;-----
;Enter the extended function mode, interruptible double-write
;-----
MOV  DX,3F0H
MOV  AL,87H
OUT  DX,AL
OUT  DX,AL
;-----
;Configure logical device 1, configuration register CRF0
;-----
MOV  DX,3F0H
MOV  AL,07H
OUT  DX,AL      ;point to logical Device Number Reg.
MOV  DX,3F1H
MOV  AL,07H     ;select device 7
OUT  DX,AL

MOV  DX,3F0H
MOV  AL,0E2H   ;device 7, CRE2
OUT  DX,AL
MOV  DX,3F1H
MOV  AL,0AH    ;Watch Dog Timer Output
OUT  DX,AL

MOV  DX,3F0H
MOV  AL,2AH    ;CR2A
OUT  DX,AL
MOV  DX,3F1H
MOV  AL,80H    ;bit7=0 -> KBRST, bit7=1 -> GP12
OUT  DX,AL

MOV  DX,3F0H
MOV  AL,07H
OUT  DX,AL
MOV  DX,3F1H
MOV  AL,08H    ;select device 8
OUT  DX,AL

MOV  DX,3F0H
MOV  AL,0F3H   ;device 8, CRF3
OUT  DX,AL
MOV  DX,3F1H
MOV  AL,06H    ;Watch Dog Timer is reset upon a
OUT  DX,AL    ;Mouse & Keyboard interrupt

MOV  DX,3F0H

```

```

MOV AL,07H
OUT DX,AL
MOV DX,3F1H
MOV AL,08H
OUT DX,AL

MOV DX,3F0H
MOV AL,0F4H ;CRF4
OUT DX,AL
MOV DX,3F1H
MOV AL,40H ;bit6 =1 -> counter counts in seconds
OUT DX,AL ;bit6 =0 -> counter counts in minutes

MOV DX,3F0H
MOV AL,07H
OUT DX,AL
MOV DX,3F1H
MOV AL,08H
OUT DX,AL

MOV DX,3F0H
MOV AL,0F2H ;CRF2
OUT DX,AL
MOV DX,3F1H
MOV AL,15 ;Time-out occurs after the value of CRF2
OUT DX,AL ;range 1~255, 00 -> disable Time-out
;-----
;Exit extended function mode
;-----
MOV DX,3F0H
MOV AL,0AAH
OUT DX,AL
.EXIT
END

```

In order to simplify the programming code, we provide a sub function for programmers to implement with their software. For DOS, Windows 95 or 98 and Window NT, the sub function format is as follow:

```

out_port (int IOport_number, int Counter_value)
IOport_number:0x3F0 -->W83977EF's configuration port.

```

```

0x2E -->W83627HF's configuration port.
Counter_value: 0 ~ 15300 (255 minutes)
(write a zero to disable the timer)

```

5.1.2 How to Test the WDT

Under DOS, Windows 95 or 98

Open a DOS command prompt and execute the following utility on the CD.

```
X:\CHIPDRV\WDT\test <n>
```

```
/* n = second value. This program can auto detect which Super  
I/O chip that is present on the board. */
```

Under Windows NT

Before you execute the program under NT, you must run the setup program under Windows NT in advance. Open a DOS command prompt window and execute the following command.

```
test977 <n>: n = second value. For W83977EF
```

5.2 Hardware Doctor Utility

This chapter introduces Hardware Doctor Utility that comes with the CPU board in conjunction with the onboard hardware monitoring function. The section describes the functions of the utility.

Hardware Doctor is a self-diagnostic system for PC and must be used with the W83L784R IC series products. It will protect PC Hardware by monitoring several critical items including Power Supply Voltage, CPU Fan speed, and CPU & System temperature. These items are important to the operation of the system; errors may result in permanent damage to the PC. If any of the hardware is operating out of its normal range or there is a malfunction, a warning message will pop up and remind user to take the appropriate action.

The Hardware Doctor utility supports Windows 98 and Windows NT. The software is stored on the ADLINK CD under the following directory:
X:\Utility\HWDDoctor\ W83L784R \WIN98 and

X:\Utility\HWDDoctor\ W83L784R\NT40.

Please install the Hardware Doctor by executing the HWM-98.exe or HWM-NT.exe respectively under Windows 98 or Windows NT.

For a more detail user's manual, please refer the HWDDoctor.PDF under the X:\Utility\HWDDoctor\ W83L784R.

5.3 Intel Preboot Execution Environment (PXE)

The cPCI-3720 series support Intel Preboot Execution Environment (PXE), which provides the capability of boot-up through a network, or even executing an OS installation. There should be a DHCP server in the network with one or more servers running PXE and MTFTP service. It could be a Windows NT/2000 server running DHCP, PXE and MTFTP service or a dedicated DHCP server with one or more additional server running PXE and MTFTP service. This section describes the major items for building a network environment with PXE support.

1. Setup a DHCP server with PXE tag configuration.
2. Install the PXE and MTFTP services
3. Make a boot image file on the PXE server (that is the boot server).
4. Enable the PXE boot function on the client computer.

For more information, please refer to pdkrel30.pdf under the directory X:\Utility\PXE_PDK.

5.4 PICMG 2.1 Hot Swap Support

The H/W design of the cPCI-3720 support Hot-Swap, meaning users may remove or insert a board without powering down the system. This SBC is hot swappable under single SBC operation environment (no peripherals). Please note that the power down control is OS dependent. When the release lever is open, it triggers a power down sequence. Once the power down sequence is completed the green Power LED (PW) goes out. The blue Hot-Swap LED (HS) turns on, it is now safe to remove the board.

When inserting the board, a successful insert occurs when the HS blue led goes out and the PW green led comes on. If the blue led stays on you will need to extract the board and re-insert it again

Note: If Hot Swap function is not necessary, it is recommended that this function be disabled in the BIOS to release its interrupt for other resources. Please refer to the cPCI-3720 BIOS manual for operational instruction.

Warranty Policy

Thank you for choosing ADLINK. To understand your rights and enjoy all the after-sales services we offer, please read the following carefully.

1. Before using ADLINK's products, please read the user 's manual and follow the instructions carefully. When sending in damaged products for repair, please attach an RMA application form.
2. All ADLINK products come with a two-year guarantee, free of repair charges.
 - The warranty period starts from the product's shipment date from ADLINK's factory
 - Peripherals and third-party products not manufactured by ADLINK will be covered by the original manufacturers' warranty
 - End users requiring maintenance services should contact their local dealers. Local warranty conditions will depend on the local dealers
3. Our repair service does not cover two-year guarantee while damages are caused by the following:
 - a. Damage caused by not following instructions on users manual.
 - b. Damage caused by carelessness on the users' part during product transportation.
 - c. Damage caused by fire, earthquakes, floods, lightening, pollution and incorrect usage of voltage transformers.
 - d. Damage caused by unsuitable storage environments with high temperatures, high humidity or volatile chemicals.
 - e. Damage caused by leakage of battery fluid when changing batteries.
 - f. Damages from improper repair by unauthorized technicians.
 - g. Products with altered and damaged serial numbers voids the guarantee
 - h. Other categories not protected under our guarantees.

4. Customers are responsible for the fees regarding transportation of damaged products to our company or to the sales office.
5. To ensure the speed and quality of product repair, please download an RMA application form from our company website www.adlinktech.com. Damaged products with RMA forms attached receive priority.

For further questions, please contact our FAE staff.

ADLINK: service@adlinktech.com

Test & Measurement Product Segment: NuDAQ@adlinktech.com

Automation Product Segment: Automation@adlinktech.com

Computer & Communication Product Segment: NuPRO@adlinktech.com;
NuIPC@adlinktech.com