

**ROCKY-3786EV/EVG(U2) serial**  
**Socket 370 bases SBC With Gigabit, 10/100Mbps**  
**Ethernet, VGA, Audio,USB2.0**  
**Ver 1.0**

Manual Revision 1.0  
Nov 4, 2002

@Copyright 2001  
All Rights Reserved.

The information in this document is subject to change without prior notice in order to improve reliability, design and function and does not represent a commitment on the part of the manufacturer.

In no event will the manufacturer be liable for direct, indirect, special, incidental, or consequential damages arising out of the use or inability to use the product or documentation, even if advised of the possibility of such damages.

This document contains proprietary information protected by copyright. All rights are reserved. No part of this manual may be reproduced by any mechanical, electronic, or other means in any form without prior written permission of the manufacturer.

**Trademarks**

ROCKY-3786EV/EVG(U2) is registered trademarks of ICP Electronics Inc., IBM PC is a registered trademark of International Business Machines Corporation. Intel is a registered trademark of Intel Corporation. Award is registered trademarks of Award Software International, Inc. Other product names mentioned herein are used for identification purposes only and may be trademarks and/or registered trademarks of their respective companies.

# Contents

Contents .....	2
Introduction.....	5
1.1 Specifications:.....	6
1.2 What You Have .....	7
Installation .....	8
2.1 ROCKY-3786EVG's Layout .....	8
2.2 Clear CMOS Setup.....	10
2.3 BIOS Protection Setting.....	11
2.4 Keyboard Power Selection.....	11
2.5 Compact Flash Card Master/Slave Mode Setting.....	12
Connection .....	13
3.1 Floppy Disk Drive Connector .....	13
3.2 Ultra ATA33/66/100 IDE Disk Drive Connector.....	14
3.3 Parallel Port.....	15
3.4 Serial Ports.....	16
3.5 Keyboard Connector.....	17
3.6 USB Port Connector .....	18
3.7 IrDA Infrared Interface Port.....	19

3.8 Fan Connector .....	19
3.9 LAN RJ45 Connector .....	20
3.10 VGA Connector .....	20
3.11 Audio Connectors .....	21
3.12 Compact Flash Storage Card Socket (Option) .....	22
3.13 External Switches and Indicators .....	23
3.14 ATX Power Connector .....	24

## Award BIOS Setup..... 26

4.1 Introduction.....	26
4.2 Starting Setup .....	26
4.3 Using Setup .....	27
4.4 Main Menu.....	28
4.5 Standard CMOS Setup .....	31
4.6 Advanced BIOS Features.....	35
4.7 Advanced Chipset Features.....	40
4.8 Integrated Peripherals .....	43
4.9 Power Management Setup.....	46
4.10 PnP/PCI Configuration Setup.....	50
4.11 PC Health Status .....	52
4.12 Frequency/Voltage Control .....	53
4.13 Defaults Menu .....	54
4.14 Supervisor/User Password Setting.....	55

4.15 Exit Selecting .....	56
<b>Appendix A. Watchdog Timer .....</b>	<b>58</b>
<b>Appendix B. Address Mapping .....</b>	<b>60</b>
IO Address Map .....	60
1st MB Memory Address Map .....	61
IRQ Mapping Table .....	61
DMA Channel Assignments .....	61
<b>Appendix C. How to Upgrade a New BIOS .....</b>	<b>62</b>
<b>Appendix D. ATX Power Supply .....</b>	<b>65</b>
<b>Appendix E. E<sup>2</sup> Key™ Function.....</b>	<b>67</b>

## Introduction

Welcome to the ROCKY-3786EVG socket 370 base Single Board Computer. Based on Intel i815EB chipset, ROCKY-3786EVG board is a PICMG form factor board, which works with high performance Pentium® III, or economical Celeron, VIA C3 processor. This product is designed for the system manufacturers, integrators, or VARs that want to provide all the performance, reliability, and quality at a reasonable price.

In addition, the ROCKY-3786EVG provides on-chip VGA, which supports up to 1600x1200 in resolution. The VGA shares the main memory.

An advanced high performance super AT I/O chip – ITE IT8712 is used in the ROCKY-3786EVG board. Which provide two UARTs are compatible with the NS16C550. The parallel port and IDE interface are compatible with IBM PC/AT architecture's.

ROCKY-3786EVG has two network controllers on board. One is a fully integrated 10/100BASE-TX controller -- Intel 82801BA integrated LAN, and another is Gigabit LAN -- Intel 82540. Both are featured with high performance networking functions and Alert-on-LAN.

ROCKY-3786EVG uses the advanced INTEL 815E Chipset, which supports up to 133MHz FSB CPU and 133MHz SDRAM memory modules.

---

## 1.1 Specifications:

- **CPU:** support socket 370 bases CPU,  
Celeron® Processor, 700MHz –1.2GHz  
Pentium® III(FC-PGA) Processor, up to 1.4GHz  
VIA C3 Processor, 733MHz or above
- **DMA channels:** 7
- **Interrupt levels:** 15
- **Chipset:** Intel 815E
- **DRAM memory:** Provides two 168-pin DIMM socket. The memory capability is up to 512MB/133MHz.
- **Ultra ATA/33/66/100 IDE Interface:** Two PCI Enhance IDE channel. The south bridge ICH2 supports Ultra ATA/33/66/100 IDE interface. To support Ultra ATA66/100 Hard disk, a specified cable must be available.
- **Floppy disk drive interface:** Single 2.88 MB, 1.44MB, 1.2MB, 720KB, or 360KB floppy disk drive.
- **CompactFlash™ interface:** Supports CompactFlash™ Type II socket for Compact Flash Disk or IBM Micro Drive.
- **Serial ports:** Two high-speed 16C550 compatible UARTs ports
- **Parallel Port :** one IEEE1284 compatible Bi-directional ports
- **IrDA port:** Supports Serial Infrared (SIR) and Amplitude Shift Keyed IR (ASKIR) interface.
- **USB port:** Supports two USB 1.1 compatible ports.  
Supports four USB 2.0 ports(U2 version only). NEC D720100A. USB2.0 controller.
- **Audio:** onboard AC'97Codec, Supports two channel Left/Right Line IN/OUT, and Left/Right speaker out, MIC IN, CD IN.
- **Watchdog timer:** From 1 second to 255 second. Reset will be generated when CPU did not periodically trigger the timer.

- **VGA Controller:** Embedded VGA controller, Screen Resolution: up to 1600x1200 in 256 Colors at 85Hz refresh.
- **Intel 82801BA embedded LAN and Inter 82540 Giga Controller:** IEEE 802.3u Auto-Negotiation support for 10BASE-T/100BASE-TX and 1000BASE-TX standard. Fast back-to-back transmission support with minimum interframe spacing. Connected to your LAN through RJ45 connector.
- **Keyboard Controller:** 8042 compatible for keyboard and PS/2 mouse
- **Power Consumption:** 5V/9A and 12V/0.1A, as running by PIII 933MHz and 256MB
- **Operating Temperature:** 0° ~ 55° C (CPU needs Cooler)

---

## 1.2 What You Have

In addition to this User's Manual, the ROCKY-3786EVG(U2) package includes the following items:

- ROCKY-3786EV/EVG(U2) socket 370 bases Single Board Computer
- One FDD cable  
One IDE Cable
- Keyboard / Mouse Adapter Y Cable
- One Printer Cable with bracket
- Two RS-232 serial ports Cable with bracket

# 2

## Installation

This chapter describes how to install the ROCKY-3786EV/EVG(U2). At first, the layout of ROCKY-3786EVG is shown, and the unpacking information that you should be careful is described. The jumpers and switches setting for the ROCKY-3786EVG's configuration, such as CPU type selection, system clock setting, and watchdog timer, are also included.

---

### 2.1 ROCKY-3786EVG's Layout

<This area is intentionally left blank>

## ROCKY-3786EVG's Layout

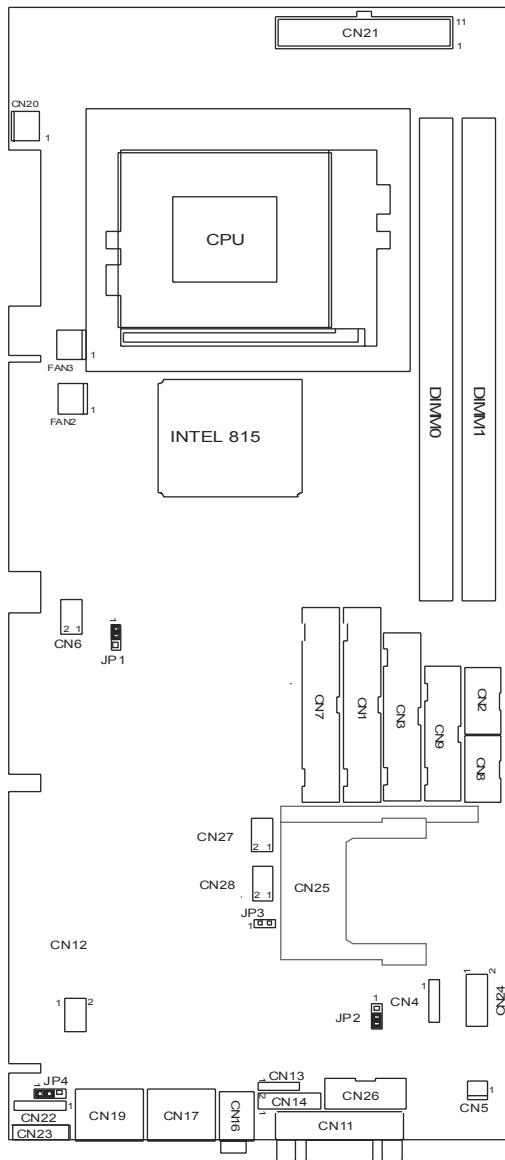

## 2.2 Clear CMOS Setup

**ROCKY-3786EVG Socket 370 base SBC**  
**With Gigabit , 10/100Mbps Ethernet , VGA , Audio**

If want to clear the CMOS Setup (for example, forgetting the password, you should clear the setup and then set the password again.), you should close the JP1 about 3 seconds, then open again. For normal operation mode, just open JP1.

- **JP1: Clear CMOS Setup**

JP1	DESCRIPTION
1-2	Keep CMOS Setup (Normal Operation)
2-3	Clear CMOS Setup

---

## 2.3 BIOS Protection Setting

To protect the bios from writing, place the cap on the location 2-3.

- **JP2: Flash Protection Setting**

JP2	DESCRIPTION
2-3	Locked
1-2	Unlocked

---

## 2.4 Keyboard Power Selection

- **JP4: Keyboard Power Selection**

JP4	DESCRIPTION
1-2	VCC
2-3	5VSB

---

## 2.5 Compact Flash Card Master/Slave Mode Setting

- **JP3: Master/Slave Mode Setting**

JP3	DESCRIPTION
OPEN	SLAVE
SHORT	MASTER

# 3

## Connection

This chapter describes how to connect peripherals, switches and indicators to the ROCKY-3786EVG board.

### 3.1 Floppy Disk Drive Connector

ROCKY-3786EV/EVG(U2) board equipped with a 34-pin daisy-chain driver connector cable.

#### • CN3: FDC CONNECTOR

PIN NO.	DESCRIPTION	PIN NO.	DESCRIPTION
1	GROUND	2	REDUCE WRITE
3	GROUND	4	N/C
5	GROUND	6	N/C
7	GROUND	8	INDEX#
9	GROUND	10	MOTOR ENABLE A#
11	GROUND	12	DRIVE SELECT B#
13	GROUND	14	DRIVE SELECT A#
15	GROUND	16	MOTOR ENABLE B#
17	GROUND	18	DIRECTION#
19	GROUND	20	STEP#
21	GROUND	22	WRITE DATA#
23	GROUND	24	WRITE GATE#
25	GROUND	26	TRACK 0#
27	GROUND	28	WRITE PROTECT#
29	N/C	30	READ DATA#
31	GROUND	32	SIDE 1 SELECT#
33	N/C	34	DISK CHANGE#

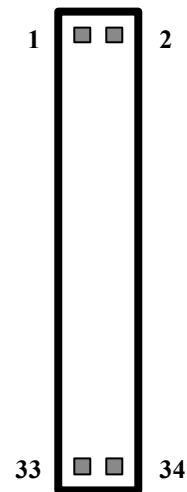

### 3.2 Ultra ATA33/66/100 IDE Disk Drive Connector

You can attach two IDE( Integrated Device Electronics) hard disk drives to the ROCKY-3786EVG IDE controller.

#### CN1 (IDE 1): Primary IDE Connector

PIN NO.	DESCRIPTION	PIN NO.	DESCRIPTION
1	RESET#	2	GROUND
3	DATA 7	4	DATA 8
5	DATA 6	6	DATA 9
7	DATA 5	8	DATA 10
9	DATA 4	10	DATA 11
11	DATA 3	12	DATA 12
13	DATA 2	14	DATA 13
15	DATA 1	16	DATA 14
17	DATA 0	18	DATA 15
19	GROUND	20	N/C
21	N/C	22	GROUND
23	IOW#	24	GROUND
25	IOR#	26	GROUND
27	N/C	28	BALE - DEFAULT
29	N/C	30	GROUND - DEFAULT
31	INTERRUPT	32	IOCS16#-DEFAULT
33	SA1	34	N/C
35	SA0	36	SA2
37	HDC CS0#	38	HDC CS1#
39	HDD ACTIVE#	40	GROUND

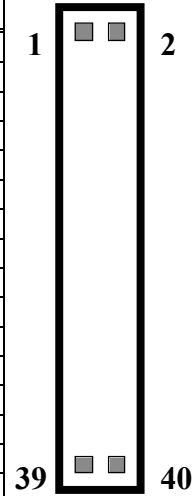

### CN7 (IDE 2): Primary IDE Connector

PIN NO.	DESCRIPTION	PIN NO.	DESCRIPTION
1	RESET#	2	GROUND
3	DATA 7	4	DATA 8
5	DATA 6	6	DATA 9
7	DATA 5	8	DATA 10
9	DATA 4	10	DATA 11
11	DATA 3	12	DATA 12
13	DATA 2	14	DATA 13
15	DATA 1	16	DATA 14
17	DATA 0	18	DATA 15
19	GROUND	20	N/C
21	N/C	22	GROUND
23	IOW#	24	GROUND
25	IOR#	26	GROUND
27	N/C	28	BALE - DEFAULT
29	N/C	30	GROUND - DEFAULT
31	INTERRUPT	32	IOCS16#-DEFAULT
33	SA1	34	N/C
35	SA0	36	SA2
37	HDC CS0#	38	HDC CS1#
39	HDD ACTIVE#	40	GROUND

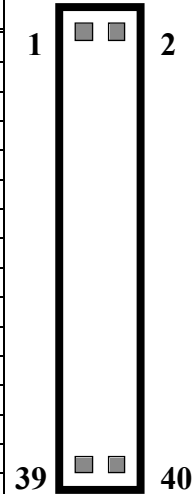

### 3.3 Parallel Port

This port is usually connected to a printer, The ROCKY-3786EV/EVG(U2) includes an on-board parallel port, and accessed through a 26-pin flat-cable connector CN9. Three modes –SPP, EPP and ECP – are supported.

#### • CN9: Parallel Port Connector

PIN NO.	DESCRIPTION	PIN NO.	DESCRIPTION
1	STROBE#	2	DATA 0
3	DATA 1	4	DATA 2
5	DATA 3	6	DATA 4
7	DATA 5	8	DATA 6
9	DATA 7	10	ACKNOWLEDGE

11	BUSY	12	PAPER EMPTY
13	PRINTER SELECT	14	AUTO FORM FEED #
15	ERROR#	16	INITIALIZE
17	PRINTER SELECT LN#	18	GROUND
19	GROUND	20	GROUND
21	GROUND	22	GROUND
23	GROUND	24	GROUND
25	GROUND	26	NC

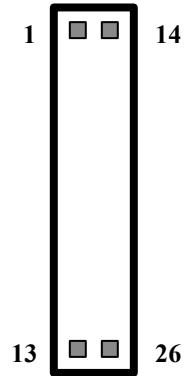

### 3.4 Serial Ports

The ROCKY-3786EVG offers two high speeds NS16C550 compatible UARTs with Read/Receive 16 byte FIFO serial ports.

**CN2:** COM1

**CN8:** COM2

#### • CN2: COM1 10-pin Connector

PIN NO.	DESCRIPTION
1	DATA CARRIER DETECT (DCD)
2	RECEIVE DATA (RXD)
3	TRANSMIT DATA (TXD)
4	DATA TERMINAL READY (DTR)

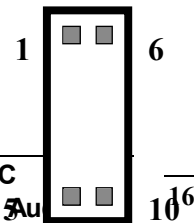

**ROCKY-3786EVG Socket 370 base SBC**  
**With Gigabit , 10/100Mbps Ethernet , VGA , Au**

5	GROUND
6	DATA SET READY (DSR)
7	REQUEST TO SEND (RTS)
8	CLEAR TO SEND (CTS)
9	RING INDICATOR (RI)
10	NC

• **CN8: COM2 10-pin Connector**

PIN NO.	DESCRIPTION
1	DATA CARRIER DETECT (DCD)
2	RECEIVE DATA (RXD)
3	TRANSMIT DATA (TXD)
4	DATA TERMINAL READY (DTR)
5	GROUND
6	DATA SET READY (DSR)
7	REQUEST TO SEND (RTS)
8	CLEAR TO SEND (CTS)
9	RING INDICATOR (RI)
10	NC

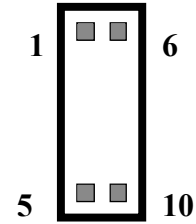

### 3.5 Keyboard Connector

The ROCKY-3786EVG provides 5-PIN Header and 6-PIN keyboard/mouse connector.

• **CN23: 6-pin Mini-DIN Keyboard/Mouse Connector**

PIN NO.	DESCRIPTION
1	KEYBOARD DATA
2	MOUSE DATA
3	GROUND
4	+5V
5	KEYBOARD CLOCK
6	MOUSE CLOCK

• **CN22: 5-pin Keyboard Connector**

**ROCKY-3786EVG Socket 370 base SBC**  
**With Gigabit , 10/100Mbps Ethernet , VGA , Audio**

PIN NO.	DESCRIPTION
1	KEYBOARD CLK
2	KEYBOARD DATA
3	N/C
4	GROUND
5	+5V

---

### 3.6 USB Port Connector

ROCKY-3786EVG provides two USB ports and U2 version provides six ports -- two USB 1.1 and four USB 2.0 ports.

•**CN6: USB 1.1**

1.	VCC
2.	GROUND
3.	DATA1-
4.	DATA1+
5.	DATA2+
6.	DATA2-
7.	GROUND
8.	VCC

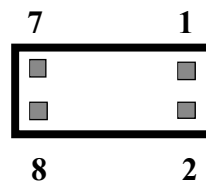

•**CN27, CN28: USB 2.0, U2 version only**

1.	VCC
2.	GROUND
3.	DATA1-
4.	DATA1+
5.	DATA2+
6.	DATA2-
7.	GROUND

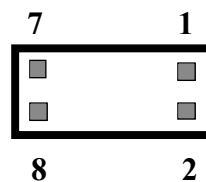

8.	VCC
----	-----

---

### 3.7 IrDA Infrared Interface Port

The ROCKY-3786EVG built-in a IrDA port which support Serial Infrared(SIR) or Amplitude Shift Keyed IR(ASKIR) interface. When use the IrDA port have to set SIR or ASKIR model in the BIOS's Peripheral Setup's COM 2. Then the normal RS-232 COM 2 will be disabled.

• **CN4: IrDA connector**

PIN NO.	DESCRIPTION
1	VCC5V
2	N/C
3	IR-RX
4	Ground
5	IR-TX

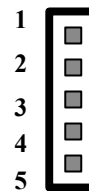



---

### 3.8 Fan Connector

The ROCKY-3785EV/ EVG provides CPU cooling fan connector. CPU connectors can supply 12V/500mA . The Fan's rotation is in full speed.

• **FAN2/FAN3: CPU Fan Connector**

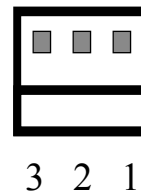
PIN NO.	DESCRIPTION
3	Sensor
2	12V
1	Ground



---

### 3.9 LAN RJ45 Connector

ROCKY-3786EVG is equipped with built-in Giga and 10/100Mbps Ethernet Controller. You can connect it to your LAN through RJ45 LAN connector. The pin assignments are as following:

• **CN17: LAN RJ45 Connector**

PIN NO.	DESCRIPTION	PIN NO.	DESCRIPTION
1	TX+	5.	N/C
2	TX-	6.	RX-
3.	RX+	7.	N/C
4.	N/C	8.	N/C

• **CN19: GIGA LAN RJ45 Connector**

PIN NO.	DESCRIPTION	PIN NO.	DESCRIPTION
1	TXA+ ( TX+ )	5.	TXC-( N/C )
2	TXA-( TX- )	6.	TXB-( RX- )
3.	TXB+( RX+ )	7.	TXD+( N/C )
4.	TXC+( N/C )	8.	TXD-( N/C )

• **CN12: LAN LED Connector**

1	100ACT+	2.	100ACT-
3	100LINK+	4.	100LINK-
5.	1G_ACT+	6.	1G_ACT-
7.	1G_ACT+	8.	1G_LINK-

---

### 3.10 VGA Connector

ROCKY-3786EVG built-in two VGA connectors for your monitor. Only one connector can be used at a time.

• **CN11: 15-pin Female Connector**

1	RED	2	GREEN
3	BLUE	4	NC
5	GROUND	6	GROUND
7	GROUND	8	GROUND
9	NC	10	GROUND
11	NC	12	DDC DAT
13	HSYNC	14	VSYNC
15	DDCCLK		

• **CN26: 10-pin Header Connector**

1	RED	2	DDCCLK
3	GREEN	4	DDC DAT
5	BLUE	6	GROUND
7	HSYNC	8	GROUND
9	VSYNC	10	GROUND

---

### 3.11 Audio Connectors

The AC'97 compliant CODEC supports 18bit AD/DA resolution and high S/N ratio. It provides 2 outputs – SPEAKER-OUT (with 250mW amplifier) and LINE-OUT (without amplifier), 3 inputs – LINE-IN, MIC-IN and CD-IN. The SPEAKER-OUT is mainly for headphone's use.

**CN14: AUDIO CONNECTOR**

1.	LEFT SPEAKER OUT SIGNAL ( <i>WITH OP AMPLIFIER</i> )
2.	RIGHT SPEAKER OUT SIGNAL ( <i>WITH OP AMPLIFIER</i> )
3.	GROUND ( <i>FOR SPK CONNECTOR</i> )
4.	GROUND ( <i>FOR LINE OUT CONNECTOR</i> )
5.	LEFT LINE OUT SIGNAL
6.	RIGHT LINE OUT SIGNAL
7.	LEFT LINE IN SIGNAL
8.	RIGHT LINE IN SIGNAL

9.	GROUND (FOR LINE IN CONNECTOR)
10.	GROUND (NO USE)
11.	MIC IN
12.	GROUND (FOR MIC IN CONNECTOR)

**CN13: CD-IN**

1.	CD LEFT SIGNAL
2.	GROUND
3.	GROUND
4.	CD RIGHT SIGNAL

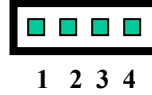

- **CN16: Left/Right Audio LINE-OUT Phone-Jack Connector**  
, Same output as LINE-OUT in CN14

1.	GROUND
2.	LEFT SIGNAL
3.	NC
4.	RIGHT SIGNAL
5.	NC

---

### 3.12 Compact Flash Storage Card Socket (Option)

The ROCKY-3786EV/EVG(U2) configures Compact Flash Storage Card in IDE Mode. This type II Socket is compatible with IBM Micro Drive.

- **CN25: Compact Flash Storage Card Socket pin assignment**

PIN NO.	DESCRIPTION	PIN NO.	DESCRIPTION
1	GROUND	26	CARD DETECT1
2	D3	27	D11
3	D4	28	D12
4	D5	29	D13
5	D6	30	D14
6	D7	31	D15
7	CS1#	32	CS3#

---

**ROCKY-3786EVG Socket 370 base SBC**  
**With Gigabit , 10/100Mbps Ethernet , VGA , Audio**

8	N/C	33	N/C
9	GROUND	34	IOR#
10	N/C	35	IOW#
11	N/C	36	OBLIGATORY TO PULL HIGH
12	N/C	37	IRQ15
13	VCC	38	VCC
14	N/C	39	MASTER/SLAVE
15	N/C	40	N/C
16	N/C	41	RESET#
17	N/C	42	IORDY
18	A2	43	N/C
19	A1	44	OBLIGATORY TO PULL HIGH
20	A0	45	ACTIVE#
21	D0	46	PDIAG#
22	D1	47	D8
23	D2	48	D9
24	N/C	49	D10
25	CARD DETECT2	50	GROUND

---

### 3.13 External Switches and Indicators

There are several external switches and indicators for monitoring and controlling your CPU board. All the functions are in the CN24 connector.

- **CN24: Multi Panel**

PIN NO.	DESCRIPTION	PIN NO.	DESCRIPTION
1.	POWER-LED +	2	SPEAKER -
3.	N/C	4	N/C
5.	POWER-LED -	6	N/C
7.	N/C	8	SPEAKER +5V
9.	N/C	10	RESET SW
11.	GND	12	RESET SW GND
13.	HDD LED +	14	HDD LED -

• **CN5: ATX Power Switch Connector**

PIN NO.	DESCRIPTION
1	PWR_BUTTON+
2	PWR_BUTTON-

• **CN20: ATX Power +5VSB and PSON# Connector**

PIN NO.	DESCRIPTION
3	Ground
2	PSON#
1	+5VSB

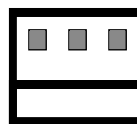

3 2 1

### 3.14 ATX Power Connector

The ROCKY-3705EV/EVG can work without backplane, while attaching external power to this ATX power connector.

• **CN21: ATX Power Supply Connector**

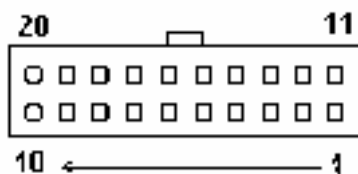

CN21 is a 20-pin ATX Power Supply Connector. Please refer to the following table for the pin assignments.

PIN NO.	DESCRIPTION	PIN NO.	DESCRIPTION
11	3.3V	1	3.3V
12	-12V	2	3.3V
13	GND	3	GND
14	PSON#	4	+5V

15	GND	5	GND
16	GND	6	+5V
17	GND	7	GND
18	-5V	8	Power good
19	+5V	9	+5VSB
20	+5V	10	+12V

# 4

## Award BIOS Setup

---

### 4.1 Introduction

This chapter discusses the Setup program written in the BIOS. It will give you a step-by-step guidance to configure your system. The user-defined configuration is then stored in battery-backed CMOS RAM, which retains the customized information while the power is off.

---

### 4.2 Starting Setup

The BIOS is immediately active when you turn on the computer. While the BIOS is in control, the Setup program can be activated in one of two ways:

1. By pressing <Del> immediately after switching the system on, or
2. By pressing the <Del> key when the following message appears at the bottom of the screen during POST (Power On Self-Test):

**Press DEL to enter SETUP**

If the message disappears before you respond and you still wish to enter Setup, restart the system to try again by turning it OFF then ON or pressing the "RESET" button on the system case. You may also restart by simultaneously pressing <Ctrl>, <Alt>, and <Delete> keys. If you do not press the keys at the correct time and the system does not boot, an error message will be displayed and you will again be asked to...

**PRESS F1 TO CONTINUE, DEL TO ENTER SETUP**

---

### 4.3 Using Setup

In general, you can use the arrow keys to highlight items, press <Enter> to select, use the PageUp and PageDown keys to change entries, press <F1> for help and press <Esc> to quit. The following table provides more details about how to navigate in the Setup program using the keyboard.

Key	Function
Up Arrow	Move to the previous item
Down Arrow	Move to the next item
Left Arrow	Move to the item on the left (menu bar)
Right Arrow	Move to the item on the right (menu bar)
Esc	Main Menu: Quit without saving changes Submenus: Exit Current page to the next higher level menu
Move Enter	Move to the item you desired
PgUp key	Increase the numeric value or make changes
PgDn key	Decrease the numeric value or make changes
+ key	Increase the numeric value or make changes
- key	Decrease the numeric value or make changes
Esc key	Main Menu -- Quit and save no changes into CMOS Status Page Setup Menu and Option Page Setup Menu -- Exit current page and return to Main Menu
F1 key	General help on Setup navigation keys
F5 key	Load previous values from CMOS
F6 key	Load the fail-safe defaults from BIOS default table
F7 key	Load the optimized defaults
F10 key	Save all the CMOS changes and exit

---

#### 4.4 Main Menu

Once you enter the AwardBIOS™ CMOS Setup Utility, the Main Menu will appear on the screen. The Main Menu allows you to select from several setup functions and two exit choices. Use the arrow keys to go through the items and press <Enter> to accept and enter the sub-menu.

CMOS Setup Utility - Copyright ( C ) 1984-2000 Award Software

Standard CMOS Features	Frequency/Voltage Control
Advanced BIOS Features	Load Fail-Safe Defaults
Advanced Chipset Features	Load Optimized Defaults
Integrated Peripherals	Set Supervisor Password
Power Management Setup	Set User Password
PnP/PCI Configurations	Save & Exit Setup
PC Health Status	Exit Without Saving
Esc : Quit	↑ ↓ ← → : Select Item
F10 : Save & Exit Setup	
Time, Date, Hard Disk Type....	

Note that a brief description of each highlighted selection appears at the bottom of the screen.

## 4.4.1 Setup Items

The main menu includes the following main setup categories. Recall that some systems may not include all entries.

---

### ***Standard CMOS Features***

Use this menu for basic system configuration. See Section 4.5 for the details.

---

### ***Advanced BIOS Features***

Use this menu to set the Advanced Features available on your system. See Section 4.6 for the details.

---

### ***Advanced Chipset Features***

Use this menu to change the values in the chipset registers and optimize your system's performance. See section 4.7 for the details.

---

### ***Integrated Peripherals***

Use this menu to configure your settings for integrated peripherals. See section 4.8 for the details.

---

### ***Power Management Setup***

Use this menu to configure your settings for power management. See section 4.9 for the details.

---

### ***PnP / PCI Configuration***

This entry appears if your system supports PnP / PCI. See section 4.10 for the details.

---

### ***PC Health Status***

Use this menu to monitor your System's Power voltage , Fan speed , CPU / System temperature . See section 4.11 for the details.

---

***Frequency/Voltage Control***

Use this menu to configure your settings for frequency/voltage control. See section 4.12 for the details.

---

***Load Fail-Safe Defaults***

Use this menu to load the BIOS default values for the minimal/stable performance for your system to operate. See section 4.13 for the details.

---

***Load Optimized Defaults***

Use this menu to load the BIOS default values that are factory settings for optimal performance system operations. While Award has designed the custom BIOS to maximize performance, the factory has the right to change these defaults to meet their needs. See section 4.13 for the details.

---

***Supervisor / User Password***

Use this menu to set User and Supervisor Passwords. See section 4.14 for the details.

---

***Save & Exit Setup***

Save CMOS value changes to CMOS and exit setup. See section 4.15 for the details.

---

***Exit Without Save***

Abandon all CMOS value changes and exit setup. See section 4.15 for the details.

## 4.5 Standard CMOS Setup

The items in Standard CMOS Setup Menu are divided into 10 categories. Each category includes no, one or more than one setup items. Use the arrow keys to highlight the item and then use the <PgUp> or <PgDn> keys to select the value you want in each item.

CMOS Setup Utility - Copyright ( C ) 1984-2000 Award Software  
Standard CMOS Features

Date: Tue, Sep 17 2002	Item Help
Time: 16:19:20	
➤ IDE Primary Master HD Model Name	Menu Level ➤
➤ IDE Primary Slave <Press Enter> None	Change the day, month, year and century
➤ IDE Secondary Master <Press Enter> None	
➤ IDE Secondary Slave <Press Enter> None	
Drive A 1.44M, 3.5 in.	
Drive B None	
Video EGA/VGA	
Halt On All,But Keyboard	
Based Memory 640K	
Extended Memory 65535K	
Total Memory 1024K	
↑↓←→Move Enter: Select +/-/PU/PD: Value F10:Save ESC: Exit F1:General Help F5:Previous Values F6:Fail-safe defaults F7:Optimized Defaults	

Figure 1: The Main Menu

### Main Menu Selections

Item	Options	Description
Date	MM DD YYYY	Set the system date.
Time	HH : MM : SS	Set the system time
IDE Primary Master	Options are in its sub menu (described in Table 3)	Press <Enter> to enter the sub menu of detailed options
IDE Primary Slave	Options are in its sub menu (described in Table 3)	Press <Enter> to enter the sub menu of detailed options
IDE Secondary Master	Options are in its sub menu (described in Table 3)	Press <Enter> to enter the sub menu of detailed options
IDE Secondary Slave	Options are in its sub menu (described in Table 3)	Press <Enter> to enter the sub menu of detailed options
Drive A Drive B	None 360K, 5.25 in 1.2M, 5.25 in 720K, 3.5 in 1.44M, 3.5 in 2.88M, 3.5 in	Select the type of floppy disk drive installed in your system
Video	EGA/VGA CGA 40 CGA 80 MONO	Select the default video device
Halt On	All Errors No Errors	Select the situation in which you want the BIOS

	All, but Keyboard All, but Diskette All, but Disk/Key	to stop the POST process and notify you
Base Memory	N/A	Displays the amount of conventional memory detected during boot up
Extended Memory	N/A	Displays the amount of extended memory detected during boot up
Total Memory	N/A	Displays the total memory available in the system

**Table 2 Main Menu Selections**

### **IDE Adapters**

The IDE adapters control the hard disk drive. Use a separate sub menu to configure each hard disk drive.

Figure 2 shows the IDE primary master sub menu.

CMOS Setup Utility – Copyright © 1984-2000 Award Software  
IDE Primary Master

IDE HDD Auto-Detection	<b>Press Enter</b>	Item Help
IDE Primary Master	Auto	Menu Level >>
Access Mode	Auto	
Capacity	15362 MB	To auto-detect the HDD's size, head... on this channel
Cylinder	29765	
Head	16	
Precomp	0	
Landing Zone	29764	
Sector	63	
↑↓←→Move    Enter: Select    +/-/PU/PD: Value    F10:Save    ESC: Exit F1:General Help F5:Previous Values    F6:Fail-safe defaults    F7:Optimized Defaults		

**ROCKY-3786EVG Socket 370 base SBC** 33  
**With Gigabit , 10/100Mbps Ethernet , VGA , Audio**

**Figure 2 IDE Primary Master sub menu**

Use the legend keys to navigate through this menu and exit to the main menu. Use Table 3 to configure the hard disk.

<b>Item</b>	<b>Options</b>	<b>Description</b>
IDE HDD Auto-detection	Press Enter	Press Enter to auto-detect the HDD on this channel. If detection is successful, it fills the remaining fields on this menu.
IDE Primary Master	None Auto Manual	Selecting 'manual' lets you set the remaining fields on this screen. Selects the type of fixed disk. "User Type" will let you select the number of cylinders, heads, etc. Note: PRECOMP=65535 means NONE !
Capacity	Auto    Display your disk drive size	Disk drive capacity (Approximated). Note that this size is usually slightly greater than the size of a formatted disk given by a disk checking program.
Access Mode	CHS	Choose the access mode for

	LBA Large Auto	this hard disk
--	----------------------	----------------

**Table 3 Hard disk selections**

---

## **4.6 Advanced BIOS Features**

This section allows you to configure your system for basic operation. You have the opportunity to select the system's default speed, boot-up sequence, keyboard operation, shadowing and security.

CMOS Setup Utility – Copyright © 1984 – 2000 Award Software  
Advanced BIOS Features

Virus Warning	Disabled	Item Help <hr/> Menu Level ➤  Allows you to choose the VIRUS warning feature for IDE Hard Disk boot sector protection. If this function is enabled and someone attempt to write data into this area, BIOS will show a warning message on screen and alarm beep
CPU Internal Cache	Enabled	
External Cache	Enabled	
CPU L2 Cache ECC Checking	Enabled	
Process Number feature	Enabled	
Quick Power On Self Test	Enabled	
LAN ( CN17/UP) BootROM	Disable	
First Boot device	Floppy	
Second Boot device	HDD-0	
Third Boot device	LS120	
Boot other device	Enabled	
Swap Floppy Drive	Disabled	
Boot Up Floppy Seek	Enabled	
Boot Up NumLock Status	On	
Gate A20 Option	Fast	
Typematic Rate Setting	Disabled	
Typematic Rate (Chars/Sec)	6	
Typematic Delay (Msec)	250	
Security Option	Setup	
Time Out(Sec.)For IDE Auto	2	
OS Select For DRAM > 64MB	Non-OS2	
Report NO FDD For Win 95	No	
Small Logo(EPA) Show	Disabled	
↑↓←→Move    Enter: Select    +/-/PU/PD: Value    F10:Save    ESC: Exit F1:General Help F5:Previous Values    F6:Fail-safe defaults    F7:Optimized Defaults		

---

### ***Virus Warning***

Allows you to choose the VIRUS Warning feature for IDE Hard Disk boot sector protection. If this function is enabled and someone attempt to write data into this area, BIOS will show a warning message on screen and alarm beep.

Enabled	Activates automatically when the system boots up causing a warning message to appear when anything attempts to access the boot sector or hard disk partition table.
Disabled	No warning message will appear when anything attempts to access the boot sector or hard disk partition table.

---

**CPU Internal Cache/External Cache**

These two categories speed up memory access. However, it depends on CPU/chipset design.

Enabled	Enable cache
Disabled	Disable cache

---

**CPU L2 Cache ECC Checking**

This item allows you to enable/disable CPU L2 Cache ECC checking. The choice: Enabled, Disabled.

---

**Processor Number Feature**

This item allows you to enable/disable support KLAMATH. The choice: Enabled, Disabled.

---

**Quick Power On Self Test**

This category speeds up Power On Self Test (POST) after you power up the computer. If it is set to Enable, BIOS will shorten or skip some check items during POST.

Enabled	Enable quick POST
Disabled	Normal POST

---

**LAN ( CN17/UP) BootROM**

Enabled/Disabled LAN BootROM

**First/Second/Third/Other Boot Device**

The BIOS attempts to load the operating system from the devices in the sequence selected in these items.

The Choice: Floppy, LS120, HDD0-3, SCSI, CDROM, ZIP 100 , LAN, Disabled.

---

**Swap Floppy Drive**

If the system has two floppy drives, you can swap the logical drive name assignments.

The choice: Enabled/Disabled.

---

**Boot Up Floppy Seek**

Seeks disk drives during boot up. Disabling speeds boot up.

The choice: Enabled/Disabled.

---

**Boot Up NumLock Status**

Select power on state for NumLock.

The choice: On/Off.

---

**Gate A20 Option**

Select if chipset or keyboard controller should control GateA20.

Normal	A pin in the keyboard controller controls GateA20
Fast	Lets chipset control GateA20

---

**Typematic Rate Setting**

Key strokes repeat at a rate determined by the keyboard controller. When enabled, the typematic rate and typematic delay can be selected.

The choice: Enabled/Disabled.

---

**Typematic Rate (Chars/Sec)**

Sets the number of times a second to repeat a key stroke when you hold the key down.

The choice: 6, 8, 10, 12, 15, 20, 24, 30.

---

**Typematic Delay (Msec)**

---

Sets the delay time after the key is held down before it begins to repeat the keystroke.

The choice: 250, 500, 750, 1000.

---

**Security Option**

Select whether the password is required every time the system boots or only when you enter setup.

System	The system will not boot and access to Setup will be denied if the correct password is not entered at the prompt.
Setup	The system will boot, but access to Setup will be denied if the correct password is not entered at the prompt.

Note: To disable security, select PASSWORD SETTING at Main Menu and then you will be asked to enter password. Do not type anything and just press <Enter>, it will disable security. Once the security is disabled, the system will boot and you can enter Setup freely.

---

**OS Select For DRAM > 64MB**

Select the operating system that is running with greater than 64MB of RAM on the system.

The choice: Non-OS2, OS2.

---

**Report No FDD For Win 95**

Whether report no FDD for Win 95 or not.

The choice: Yes, No.

---

**Small Logo(EPA) Show**

Enabled/Disabled Small LOGO(EPA) Show

---

## 4.7 Advanced Chipset Features

CMOS Setup Utility – Copyright © 1984 – 2000 Award Software  
Advanced Chipset Features

SDRAM CAS Latency Time	3	Item Help
SDRAM Cycle Time Tras/Trc	Auto	
SDRAM RAS-to-CAS Delay	Auto	Menu Level ➤
SDRAM RAS Precharge Time	Auto	
System BIOS Cacheable	Disabled	
Video BIOS Cacheable	Disabled	
Memory Hole At 15M-16M	Disabled	
CPU Latency Timer	Enabled	
Delayed Transaction	Enabled	
AGP Graphics Aperture Size	64MB	
System Memory Frequency	Auto	
Power – Supply Type	ATX	
Special NT4.0 DRAM Report	Disabled	
On-Chip VGA	Enabled	
↑↓←→Move Enter: Select +/-/PU/PD: Value F10:Save ESC: Exit F1:General Help F5:Previous Values F6:Fail-safe defaults F7:Optimized Defaults		

This section allows you to configure the system based on the specific features of the installed chipset. This chipset manages bus speeds and access to system memory resources, such as DRAM and the external cache. It also coordinates communications between the conventional ISA bus and the PCI bus. It must be stated that these items should never need to be altered. The default settings have been chosen because they provide the best operating conditions for your system.

### **DRAM Settings**

The first chipset settings deal with CPU access to dynamic random access memory (DRAM). The default timings have been carefully chosen and should only be altered if data is being lost. Such a scenario might well occur if your system had mixed speed DRAM chips installed so that greater delays may be required to preserve the integrity of the data held in the slower memory chips.

---

**SDRAM CAS Latency Time**

When synchronous DRAM is installed, the number of clock cycles of CAS latency depends on the DRAM timing.

The Choice: 2, 3

---

**SDRAM Cycle Time *Tras/Trc***

Select the number of SCLKs for an access cycle.

The Choice: 5/7, 6/8.

---

**SDRAM RAS-to-CAS Delay**

This field lets you insert a timing delay between the CAS and RAS strobe signals, used when DRAM is written to, read from, or refreshed. *Fast* gives faster performance; and *Slow* gives more stable performance. This field applies only when synchronous DRAM is installed in the system.

The Choice: 2, 3.

---

**SDRAM RAS Precharge Time**

If an insufficient number of cycles is allowed for the RAS to accumulate its charge before DRAM refresh, the refresh may be incomplete and the DRAM may fail to retain data. *Fast* gives faster performance; and *Slow* gives more stable performance. This field applies only when synchronous DRAM is installed in the system.

The Choice: 2, 3.

---

**System BIOS Cacheable**

Selecting *Enabled* allows caching of the system BIOS ROM at F0000h-FFFFFh, resulting in better system performance. However, if any program writes to this memory area, a system error may result.

The choice: Enabled, Disabled.

---

**Video BIOS Cacheable**

Select Enabled allows caching of the video BIOS , resulting in better system performance. However, if any program writes to this memory area, a system error may result.

The Choice: Enabled, Disabled.

---

**Memory Hole At 15M-16M**

You can reserve this area of system memory for ISA adapter ROM. When this area is reserved, it cannot be cached. The user information of peripherals that need to use this area of system memory usually discusses their memory requirements.

The Choice: Enabled, Disabled.

---

**CPU Latency Timer**

Enabled :CPU cycle will only be Deferred after in has been in a “Snoop Stall” for 31 clocks and another ADS# has arrived.

Disabled: CPU cycle will only be Deferred immediately after the GMCH receives another ADS#.

The Choice: Enabled, Disabled.

---

**Delay Transaction**

The chipset has an embedded 32-bit posted write buffer to support delay transactions cycles. Select *Enabled* to support compliance with PCI specification version 2.1.

The Choice: Enabled, Disabled.

---

**AGP Graphics Aperture Size**

Select the on-chip video window size for VGA drive use.

The Choice: 32MB, 64MB,

---

**System Memory Frequency**

When AUTO , system can automatic set memory frequency .

AUTO / 100 / 133 Memory frequency

---

---

### **Power Supply**

When ATX , your system use ATX power supply .  
ATX/AT power supply.

---

### **On – chip VGA**

When Enable , your can enable on chip VGA controller .  
Enable/Disable On – Chip VGA.

---

## **4.8 Integrated Peripherals**

CMOS Setup Utility – Copyright © 1984 – 2000 Award Software  
Integrated Peripherals

		Item Help
On-Chip Primary PCI IDE	Enabled	
On-Chip Secondary PCI IDE	Enabled	
IDE Primary Master PIO	Auto	Menu Level ➤
IDE Primary Slave PIO	Auto	If your IDE hard drive
IDE Secondary Master PIO	Auto	supports block mode
IDE Secondary Slave PIO	Auto	select Enabled for
IDE Primary Master UDMA	Auto	automatic detection
IDE Primary Slave UDMA	Auto	of the optimal number
IDE Secondary Master UDMA	Auto	of block read/write
IDE Secondary Slave UDMA	Auto	per sector the drive
Init Display First	PCI Slot	can support
USB (CN6) Controller	Enabled	
USB (CN6) Keyboard Support	Enabled	
AC97 Audio	Enabled	
IDE HDD Block Mode	Enabled	
Power ON Function	BUTTON ONLY	
KB Power On Password	Enter	
Hot Key Power ON	Ctrl-F1	
Onboard FDC Controller	Enabled	
Onboard Serial Port 1	3F8/IRQ4	
Onboard Serial Port 2	2F8/IRQ3	
UART Mode Select	Normal	
UR2 Duplex Mode	Half	
Onboard Parallel Port	378/IRQ7	
Parallel Port Mode	SPP	
ECP Mode Use DMA	3	
PWRON After PER-Fail	Off	

↑↓←→ Move	Enter: Select	+/-/PU/PD: Value	F10:Save	ESC: Exit
F1:General Help				
F5:Previous Values	F6:Fail-safe defaults	F7:Optimized Defaults		

***There are some item in bottom of scroll.***

---

### ***On-Chip Primary/Secondary PCI IDE***

The integrated peripheral controller contains an IDE interface with support for two IDE channels. Select *Enabled* to activate each channel separately.

The choice: Enabled, Disabled.

---

### ***IDE Primary/Secondary Master/Slave PIO***

The four IDE PIO (Programmed Input/Output) fields let you set a PIO mode (0-4) for each of the four IDE devices that the onboard IDE interface supports. Modes 0 through 4 provide successively increased performance. In Auto mode, the system automatically determines the best mode for each device.

The choice: Auto, Mode 0, Mode 1, Mode 2, Mode 3, Mode 4.

---

### ***IDE Primary/Secondary Master/Slave UDMA***

Ultra DMA-33/66 implementation is possible only if your IDE hard drive supports it and the operating environment includes a DMA driver (Windows 95 OSR2 or a third-party IDE bus master driver). If your hard drive and your system software both support Ultra DMA-33/66, select Auto to enable BIOS support.

The Choice: Auto, Disabled.

---

### ***USB Controller***

Select *Enabled* if your system contains a Universal Serial Bus (USB) controller and you have USB peripherals.

The Choice: Enabled, Disabled.

---

### ***USB Keyboard Support***

Select *Enabled* if your system contains a Universal Serial Bus (USB) controller and you have a USB keyboard.

The Choice: Enabled, Disabled.

---

***Onboard Audio Device***

This item allows you to decide to enable/disable the CMIDER CMI8738LX chipset family to support 6CH DAC for AC-3 5.1 channel purpose.

The choice: Enabled, Disabled.

---

***IDE HDD Block Mode***

Block mode is also called block transfer, multiple commands, or multiple sector read/write. If your IDE hard drive supports block mode (most new drives do), select Enabled for automatic detection of the optimal number of block read/writes per sector the drive can support.

The choice: Enabled, Disabled

---

***Onboard FDC Controller***

Select Enabled if your system has a floppy disk controller (FDC) installed on the system board and you wish to use it. If you install and-in FDC or the system has no floppy drive, select Disabled in this field.

The choice: Enabled, Disabled

---

***Onboard Serial Port 1/Port 2***

Select an address and corresponding interrupt for the first and second serial ports.

The choice: 3F8/IRQ4, 2E8/IRQ3, 3E8/IRQ4, 2F8/IRQ3, Disabled,  
Auto

---

***UART Mode Select***

Select a serial port 2 operation mode.

The choice: Normal, IrDA, ASKIR, SCR

---

***Onboard Parallel Port***

Select an address and corresponding interrupt for the parallel ports.

The choice: 378/IRQ7, 278/IRQ5, 3BC/IRQ7, Disabled,

---

***Parallel Port Mode***

---

Select a parallel operation mode.  
The choice: SPP, EPP, ECP,ECP+EPP

---

## **4.9 Power Management Setup**

The Power Management Setup allows you to configure you system to most effectively save energy while operating in a manner consistent with your own style of computer use.

CMOS Setup Utility – Copyright © 1984 – 2000 Award Software  
Power Management Setup

ACPI Function	Enabled	Item Help
ACPI Suspend Type	S1<POS>	
Power Management	User Define	Menu Level ➤
Video Off Method	DPMS	
Video Off In Suspend	Yes	
Suspend Type	Stop Grant	
MODEM Use IRQ	NA	
Suspend Mode	Disabled	
HDD Power Down	Disabled	
Soft-Off by PWR-BTTN	Instant-Off	
Power On by Ring	Enabled	
Resume by Alarm	Disabled	
X Date(of Month) Alarm	0	
X Time(hh:mm:ss) Alarm	0 : 0 : 0	
** Reload Global Timer Events **		
Primary IDE 0	Disabled	
Primary IDE 1	Disabled	
Secondary IDE 0	Disabled	
Secondary IDE 1	Disabled	
FDD,COM,LPT Port	Disabled	
PCI, PIRQ[A-D]#	Disabled	
↑↓←→Move Enter: Select +/-/PU/PD: Value F10:Save ESC: Exit F1:General Help F5:Previous Values F6:Fail-safe defaults F7:Optimized Defaults		

---

### ***Power Management***

This category allows you to select the type (or degree) of power saving and is directly related to the following modes:

1. HDD Power Down
2. Doze Mode

### 3. Suspend Mode

There are four selections for Power Management, three of which have fixed mode settings.

Disable (default)	No power management. Disables all four modes
Min. Power Saving	Minimum power management. Doze Mode = 1 hr. Standby Mode = 1 hr., Suspend Mode = 1 hr., and HDD Power Down = 15 min.
Max. Power Saving	Maximum power management -- <b>ONLY AVAILABLE FOR SL CPU's</b> . Doze Mode = 1 min., Standby Mode = 1 min., Suspend Mode = 1 min., and HDD Power Down = 1 min.
User Defined	Allows you to set each mode individually. When not disabled, each of the ranges are from 1 min. to 1 hr. except for HDD Power Down which ranges from 1 min. to 15 min. and disable.

---

#### ***Video Off Method***

This determines the manner in which the monitor is blanked.

V/H SYNC+Blank	This selection will cause the system to turn off the vertical and horizontal synchronization ports and write blanks to the video buffer.
Blank Screen	This option only writes blanks to the video buffer.
DPMS	Initial display power management signaling.

---

#### ***Video Off In Suspend***

This determines the manner in which the monitor is blanked.

The choice: Yes, No.

---

#### ***Suspend Type***

Select the Suspend Type.

The choice: PWRON Suspend, Stop Grant.

---

#### ***Suspend Mode***

When enabled and after the set time of system inactivity, all devices except the CPU will be shut off.

The choice: 1Min, 2Min, 4Min, 8Min, 12Min, 20Min, 30Min, 40Min, 1Hour, Disabled.

---

#### **HDD Power Down**

When enabled and after the set time of system inactivity, the hard disk drive will be powered down while all other devices remain active.

The choice: 1Min, 2Min, 3Min, 4Min, 5Min, 6Min, 7Min, 8Min, 9Min, 10Min, 11Min, 12Min, 13Min, 14Min, 15Min, Disabled.

---

#### **PM EVENTS**

PM events are I/O events whose occurrence can prevent the system from entering a power saving mode or can awaken the system from such a mode. In effect, the system remains alert for anything which occurs to a device which is configured as *Enabled* , even when the system is in a power down mode.

**Primary IDE 0**

**Primary IDE 1**

**Secondary IDE 0**

**Secondary IDE 1**

**FDD, COM, LPT Port**

**PCI PIRQ[A-D] #**

## 4.10 PnP/PCI Configuration Setup

This section describes configuring the PCI bus system. PCI, or **Personal Computer Interconnect**, is a system which allows I/O devices to operate at speeds nearing the speed the CPU itself uses when communicating with its own special components. This section covers some very technical items and it is strongly recommended that only experienced users should make any changes to the default settings.

CMOS Setup Utility – Copyright © 1984-2000 Award Software  
PnP/PCI Configurations

PNP OS Installed	<b>NO</b>	Item Help
Reset Configuration Data	Disabled	----- Menu Level >
Resources Controlled By	Auto(ESCD)	Default is Disabled. Select Enabled to reset Extended System Configuration Data(ESCD) when you exit Setup if you have installed a new add-on and the system reconfiguration has caused such a serious conflict that the OS cannot boot
x IRQ Resources	Press	
Enter		
x DMA Resources	Press	
Enter		
PCI/VGA Palette Snoop	Disabled	
PCI Latency Timer(CLK)	32	
↑↓←→Move Enter: Select +/-/PU/PD: Value F10:Save ESC: Exit F1:General Help F5:Previous Values F6:Fail-safe defaults F7:Optimized Defaults		

### **Reset Configuration Data**

Normally, you leave this field Disabled. Select Enabled to reset Extended System Configuration Data (ESCD) when you exit Setup if you have installed a new add-on and the system reconfiguration has caused such a serious conflict that the operating system can not boot.

The choice: Enabled, Disabled .

---

**Resource controlled by**

The Award Plug and Play BIOS has the capacity to automatically configure all of the boot and Plug and Play compatible devices. However, this capability means absolutely nothing unless you are using a Plug and Play operating system such as Windows®95. If you set this field to "manual" choose specific resources by going into each of the sub menu that follows this field (a sub menu is preceded by a "➤").

The choice: Auto(ESCD), Manual.

---

**IRQ Resources**

When resources are controlled manually, assign each system interrupt a type, depending on the type of device using the interrupt.

---

**IRQ3/4/5/7/9/10/11/12/14/15 assigned to**

This item allows you to determine the IRQ assigned to the ISA bus and is not available to any PCI slot. Legacy ISA for devices compliant with the original PC AT bus specification, PCI/ISA PnP for devices compliant with the Plug and Play standard whether designed for PCI or ISA bus architecture.

The Choice: PCI Device, Reserved.

---

**PCI/VGA Palette Snoop**

Leave this field at *Disabled*.

Choices are Enabled, Disabled.

---

## 4.11 PC Health Status

CMOS Setup Utility – Copyright © 1984-2000 Award Software  
PC Health Status

CPU VCORE	1.40V	Item Help
VTT	1.23V	-----
+3.3V	3.29V	Menu Level ➤
+5V	4.99V	
+12V	12.03V	
-12V	(-	
)11.86V		
-5V	(-)5.10V	
+5VSB	5.02V	
Voltage Battery	3.07V	
CPU Temperature	38°C	
System Temperature	37°C	
Fan 2 Spend	6026	
Fan 3 Spend	0	
↑↓←→ Move Enter: Select +/-/PU/PD: Value F10:Save ESC: Exit F1:General Help F5:Previous Values F6:Fail-safe defaults F7:Optimized Defaults		

Note: normal CPU Fan RPM is over than 5000 RPM. If your CPU Fan RPM is less than that figure, something is wrong and the CPU will be in overheat condition. Make sure that the connection at Fan1/Fan2 is correct.

---

## 4.12 Frequency/Voltage Control

CMOS Setup Utility – Copyright © 1984-2000 Award Software  
Frequency/Voltage Control

Auto Detect DIMM/PCI Clk	Disabled	Item Help
Spread Spectrum	Disabled	-----
CPU Host/PCI Clock	Disabled	Menu Level   ➤
CPU Clock Ratio	X 4	

↑↓←→ Move   Enter: Select   +/-/PU/PD: Value   F10:Save   ESC: Exit  
F1:General Help  
F5:Previous Values   F6:Fail-safe defaults   F7:Optimized Defaults

---

### ***Auto Detect DIMM/PCI Clk***

This item allows you to enable/disable auto detect DIMM/PCI Clock.  
The choice: Enabled, Disabled.

---

### ***Spread Spectrum***

This item allows you to enable/disable the spread spectrum modulate.  
The choice: Enabled, Disabled.

---

### ***CPU Host / PCI Clock***

This item allows you to select CPU Host and PCI clock.

The choice: Default, 130/33, 133/33, 137/34, 140/35, 145/36, 150/38( M )

---

### **CPU Clock Ratio**

This item allows you to select CPU clock ratio.

The choice: 4, 4.5, 5, 5.5, 6, 6.5, 7, 7.5, 8, 8.5, 9, 9.5, 10, 10.5, 11, 11.5, 12.

---

## **4.13 Defaults Menu**

Selecting “Defaults” from the main menu shows you two options which are described below

### **Load Fail-Safe Defaults**

When you press <Enter> on this item you get a confirmation dialog box with a message similar to:

Load Fail-Safe Defaults (Y/N) ? **N**

Pressing ‘Y’ loads the BIOS default values for the most stable, minimal-performance system operations.

### **Load Optimized Defaults**

When you press <Enter> on this item you get a confirmation dialog box with a message similar to:

Load Optimized Defaults (Y/N) ? **N**

Pressing ‘Y’ loads the default values that are factory settings for optimal performance system operations.

---

## 4.14 Supervisor/User Password Setting

You can set either supervisor or user password, or both of them. The differences between are:

**supervisor password :**

can enter and change the options of the setup menus.

**user password :**

just can only enter but do not have the right to change the options of the setup menus. When you select this function, the following message will appear at the center of the screen to assist you in creating a password.

ENTER PASSWORD:

Type the password, up to eight characters in length, and press <Enter>. The password typed now will clear any previously entered password from CMOS memory. You will be asked to confirm the password. Type the password again and press <Enter>. You may also press <Esc> to abort the selection and not enter a password.

To disable a password, just press <Enter> when you are prompted to enter the password. A message will confirm the password will be disabled. Once the password is disabled, the system will boot and you can enter Setup freely.

PASSWORD DISABLED:

When a password has been enabled, you will be prompted to enter it every time you try to enter Setup. This prevents an unauthorized person from changing any part of your system configuration.

Additionally, when a password is enabled, you can also require the BIOS to request a password every time your system is rebooted. This would prevent unauthorized use of your computer.

You determine when the password is required within the BIOS Features Setup Menu and its Security option (see Section 3). If the Security option is set to password will be required both at boot and at entry to Setup. If set to "Setup", prompting only occurs when trying to enter Setup.

---

## 4.15 Exit Selecting

### Save & Exit Setup

Pressing <Enter> on this item asks for confirmation:

**Save to CMOS and EXIT (Y/N)?** **Y**

Pressing "Y" stores the selections made in the menus in CMOS – a special section of memory that stays on after you turn your system off. The next time you boot your computer, the BIOS configures your system according to the Setup selections stored in CMOS. After saving the values the system is restarted again.

### Exit Without Saving

Pressing <Enter> on this item asks for confirmation:

**Quit without saving (Y/N)?** **Y**

This allows you to exit Setup without storing in CMOS any change. The previous selections remain in effect. This exits the Setup utility and restarts your computer.



## Appendix A. Watchdog Timer

The Watchdog Timer is a device to ensure that standalone systems can always recover from abnormal conditions that cause the system to crash. These conditions may result from an external EMI or a software bug. When the system stops working, hardware on the board will perform hardware reset (cold boot) to bring the system back to a known state.

Three I/O ports control the operation of Watch-Dog Timer.

443 (hex)	Write	Set Watchdog Time period
443 (hex)	Read	Enable the refresh the Watchdog Timer.
043/843 (hex)	Read	Disable the Watch-Dog Timer.

Prior to enable the Watch-Dog Timer, user has to set the time-out period. The resolution of the timer is 1 second and the range of the timer is from 1 sec to 255 sec. You need to send the time-out value to the I/O port – 443H, and then enable it by reading data from the same I/O port – 443H. This will activate the timer that will eventually time out and reset the CPU board. To ensure that this reset condition won't occur, the Watch-Dog Timer must be periodically refreshed by reading the same I/O port 443H. This must be done within the time-out period, please refer to the example program. Finally, we have to disable the Watch-Dog timer by reading the I/O port -- 843H or 043H. Otherwise the system could reset unconditionally.

A tolerance of at least 5% must be maintained to avoid unknown routines in the operating system (DOS), such as disk I/O that can be very time-consuming. Therefore if the time-out period has been set to 10 seconds, the I/O port 443H must be read within 7 seconds.

**Example assembly program:**

```
TIMER_PORT = 443H  
TIMER_START = 443H  
TIMER_STOP = 843H
```

**;;INITIAL TIMER COUNTER**

```
MOV DX, TIMER_PORT  
MOV AL, 8 ;;8 seconds  
OUT DX, AL  
MOV DX, TIMER_START  
IN AL, DX. ;;start counter
```

```
W_LOOP:  
MOV DX, TIMER_STOP  
IN AL, DX  
MOV DX, TIMER_START  
IN AL, DX ;;restart counter
```

**;;ADD YOUR APPLICATION HERE**

```
CMP EXIT_AP, 0  
JNE W_LOOP  
MOV DX, TIMER_STOP  
IN AL, DX  
;;EXIT AP
```

## Appendix B. Address Mapping

---

### IO Address Map

I/O address Range	Description
000-01F	DMA Controller #1
020-021	Interrupt Controller #1, Master
040-05F	8254 timer
060-06F	8042 (Keyboard Controller)
070-07F	Real time Clock, NMI Mask
080-09F	DMA Page Register
0A0-0BF	Interrupt Controller #2
0C0-0DF	DMA Controller #2
0F0	Clear Math Coprocessor Busy
0F1	Reset Math Coprocessor
0F2	Core logic programming configuration
0F8-0FF	Math Coprocessor
1F0-1F8	Fixed Disk
200-207	Game I/O
278-27F	Parallel Printer Port 2 (LPT3)
2E8-2EF	Serial Port 4
2F8-2FF	Serial Port 2
300-31F	Prototype Card
360-36F	Reserved
378-37F	Parallel Printer Port 1 (LPT2)
3B0-3BF	Monochrome Display and Printer Adapter (LPT1)
3C0-3CF	Reserved
3D0-3DF	Color/Graphics Monitor Adapter
3E8-3EF	Serial Port 3
3F0-3F7	Diskette Controller
3F8-3FF	Serial Port 1

---

## 1st MB Memory Address Map

Memory address	Description
00000-9FFFF	System memory
A0000-BFFFF	VGA buffer
C0000-C7FFF	VGA BIOS
F0000-FFFFF	System BIOS
1000000-	Extend BIOS

\*Default setting

---

## IRQ Mapping Table

IRQ0	System Timer	IRQ8	RTC clock
IRQ1	Keyboard	IRQ9	Available
IRQ2	Cascade to IRQ Controller	IRQ10	AC'97 CODEC
IRQ3	COM2	IRQ11	Intel 82562ET LAN
IRQ4	COM1	IRQ12	PS/2 mouse
IRQ5	Available	IRQ13	FPU
IRQ6	FDC	IRQ14	Primary IDE
IRQ7	Printer	IRQ15	Secondary IDE

---

## DMA Channel Assignments

Channel	Function
0	Available
1	Available
2	Floppy disk ( 8-bit transfer )
3	Available
4	Cascade for DMA controller 1
5	Available
6	Available
7	Available

## Appendix C. How to Upgrade a New BIOS

You can install an upgrade BIOS for the ROCKY-3786EV/EVG(U2) that you can download from the manufacturer's web site ( [www.e-icp.com.tw](http://www.e-icp.com.tw) ). New BIOS may provide support for new peripherals ,improvements in performance or fixes to addressed known bugs.

BIOS Update Procedure:

1. Make a boot disk. Go to the DOS command prompt in MS-DOS or Windows 9x and, with an available floppy disk in "A", type "format A: /s" That will format the floppy and transfer the needed system files to it.

NOTES:

A. This procedure will erase any prior data on that floppy, so please Proceed accordingly.

B. Typically four files will be transferred, only COMMAND.COM being visible when running a simple directory listing.

C. Please leave the diskette UN-write protected for the balance of this procedure.

2. Download the BIOS upgrade file and awdfash.exe utility from a ICP web site to a temp directory on your hard drive, or directly to the floppy you made in step 1..

3. Copy ( BIOS file and awdfash.exe )two files to the boot floppy.

4. Reboot the system to the DOS command prompt using the boot diskette you just made.

5. At the DOS command prompt type , "awdf flash filename.xxx", where filename.xxx is the file name of the BIOS file . Hit enter.

6. Your first option, in sequence, will be to save the old BIOS. We recommend that you do that in case, for whatever reason, you decide you don't wish to use the new version once it is installed.

NOTES:

A. If you decide to save the old BIOS, PLEASE make sure you do NOT save it to the same file name as the new BIOS - if you use the same BIOS name the old file will be written over the new file with NO warning prompt. A simple file name to save the old BIOS to is OLDBIOS.BIN.

B. If you do NOT decide to save the old BIOS, PLEASE at least write down the version number of the old BIOS and store that information with your important computer documents. Enter N (for "no") and skip to step 9.

7. To save the old BIOS, hit Y (for "yes")

8. Enter a name for the OLD BIOS file and hit enter.

NOTE:PLEASE be sure you do NOT save the old BIOS file to the same file name as the new BIOS - if you use the same BIOS name, the old file will write over the new BIOS file WITHOUT a warning prompt. A simple file name for saving the old BIOS to is OLDBIOS.BIN.

9. Your second option, in sequence, will be whether you want to flash your BIOS. Enter Y (for "yes").

NOTE: This is the critical step. Once you hit the enter key, do NOT

touch the keyboard, the reset button, or power switch while the flashing is in progress. There will be bar progressing across the screen while the flashing is progressing.

10. When the flashing process is complete, you will be asked to reset or power off the system. Remove the floppy diskette from the floppy drive and either hit the reset button or the power button.

11. Reboot the system and note that the BIOS version on the initial boot-up screen has changed to the new BIOS version. Your BIOS upgrade is now complete.

#### Recovering Your Old BIOS:

1. Assuming you have the floppy made during the upgrade procedure noted above, boot the system with that diskette in the floppy drive. If you do not have floppy made during the upgrade procedure noted above, you will need to repeat steps 1 through 3 (above) for the version of the BIOS you wish to recover to.

2. Complete steps 4, 5, 6B, 9, 10, and 11 (above) substituting the name of the BIOS you wish to recover for the upgrade BIOS at step 5.

Install screen :

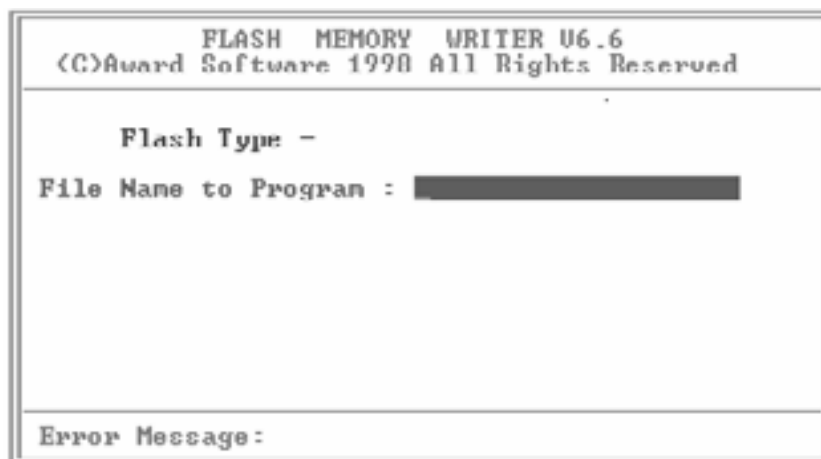

With Gigabit , 10/100Mbps Ethernet , VGA , Audio

## Appendix D. ATX Power Supply

The following notes show how to connect ATX Power Supply to the backplanes and / or the ISBC card.

### A. For backplanes with ATX Connector

1. Please, disconnect the AC cord of the Power Supply from the AC source to prevent sudden electric surge to the board.
2. Please, check the type of your CPU board. All CPU board listed on the next page support ATX power supply but has two types of power switch connection:
  - 2.1. **ROCKY-3786EV/EVG(U2) (through Power Button & GND):**

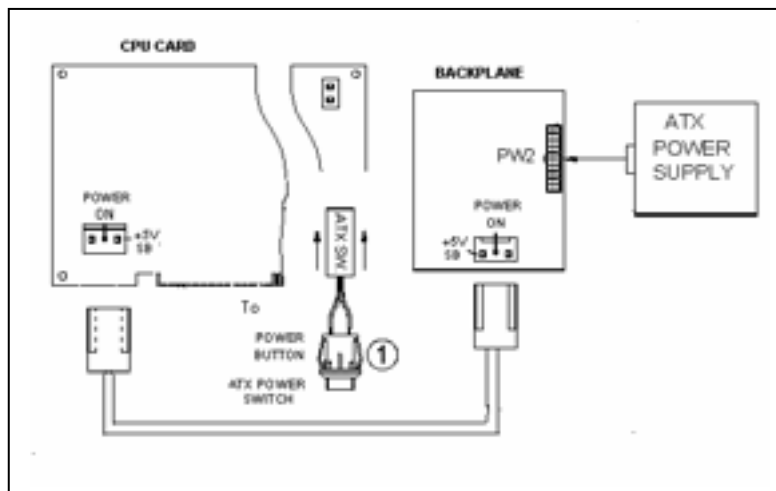

Connect the ATX power button switch to the CN5 (power button).  
And connect the power cable from backplane to CN20 of CPU card.

If you want to turn ON the system, just press the button once.  
And if you want to turn off the power supply, please press the  
ATX power switch button for about 4 seconds.

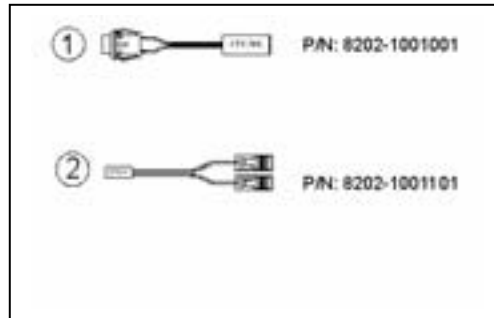

### ***B. For the backplanes with ATX power supply connector***

For some SBC without ATX power ON/OFF function, then you can control the ATX power supply through backplane's PS-ON connector. Refer to the figure below: for the backplanes with ATX connector, the connection can be made simply as following:

1. Connect the ON/OFF (ordinary one) switch to Pin 2 (PS ON) and Pin 3 (GND) of connector CN2
2. You may now turn the power ON/OFF by the power switch

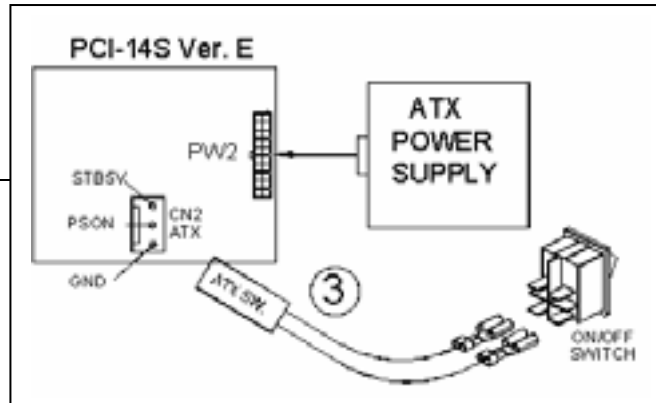

## Appendix E. E<sup>2</sup> Key™ Function

The ROCKY-3786EVG provides an outstanding E<sup>2</sup>KEY™ function for system integrator. Based on the E<sup>2</sup>KEY™, you can free to store the ID Code, Password or Critical Data in the 1Kbit EEPROM. Because the EEPROM is nonvolatile memory, you don't have to worry for losing very important data.

Basically the E<sup>2</sup>KEY™ is based on a 1Kbit EEPROM which is configured to 64 words(from 0 to 63). You could access (read or write) each word at any time.

When you start to use the E<sup>2</sup>KEY™ you should have the utility in the package. The software utility will include four files as follows,

**README.DOC**  
**E2KEY.OBJ**  
**EKEYDEMO.C**  
**EKEYDEMO.EXE.**

The E2KEY.OBJ provides two library functions for user to integrate their application with E<sup>2</sup>KEY™ function. These library (**read\_e2key** and **write\_e2key**) are written and compiled in C language. Please check the following statement, then you will know how to implement it easily.

**unsigned int read\_e2key(unsigned int address)**

/\* This function will return the E<sup>2</sup>KEY™'s data at address. The address range is from 0 to 63. Return data is one word, 16 bits

**\*/void write\_e2key(unsigned int address, unsigned data)**

/\* This function will write the given data to E<sup>2</sup>KEY™ at certain address. The address range is from 0 to 63. The data value is from 0 to 0xffff. \*/

To easily start to use the function, please refer to the included EKEYDEMO.C code at first.

Please note that the E<sup>2</sup>KEY™ function is based on the working of parallel port. So you should enable the ROCKY-3702EV's parallel port, otherwise it will not work.