

Wireless Radio Modem User's Manual

Warranty

All products manufactured by ICP DAS are warranted against defective materials for a period of one year from the date of delivery to the original purchaser.

Warning

ICP DAS assume no liability for damages consequent to the use of this product. ICP DAS reserves the right to change this manual at any time without notice. The information furnished by ICP DAS is believed to be accurate and reliable. However, no responsibility is assumed by ICP DAS for its use, nor for any infringements of patents or other rights of third parties resulting from its use.

Copyright

Copyright 1999 by ICP DAS. All rights are reserved.

Trademark

The names used for identification only maybe registered trademarks of their respective companies.

Date:2001-10

Table of Contents

1. Introduction	4
1.1 Block Diagram	4
1.2 Specifications	5
1.2.1 SST-900EXT Wireless Radio Modem	5
1.2.2 SST-2400EXT Wireless Radio Modem	6
1.2.3 SST-900A External 900MHz Antenna.....	7
1.2.4 SST-2400A-3 External 2.4GHz Antenna	7
1.2.5 SST-2400A-12 External 2.4GHz Antenna ...	8
1.2.6 SST-2400A-13 External 2.4GHz Antenna ...	8
1.3 Pin Assignment	9
1.4 Jumper Setting	10
1.5 Wire Connection	11
1.6 Dimension	14
1.6.1 SST-900EXT and SST-2400EXT	14
1.6.2 DIN-RAIL Mounting	15
1.6.4 Pannel Mounting	16
2 Configuration	17
2.1 Full-duplex and Half-duplex	17
2.2 Synchronous and Asynchronous.....	18
2.3 Configuration Select	19
2.4 Operation Mode 1	20

2.5 Operation Mode 2	21
2.6 Operation Mode 3	22
3 Application	23
3.1 Peer-to-Peer Communication.....	23
3.2 Asynchronous Connection	24
3.3 Multiple PCs Communication	25
3.4 Connect I-7000 Modules	26
3.5 Communication Bridge	27
3.6 Network Communication.....	28

1. Introduction

The SST-900 and SST-2400 are radio modems that can be used in multiple access networking. The transmission method includes peer-to-peer, multi-point structure for wireless data communication. Based on direct sequence spread spectrum and RF technology operating in ISM bands, 902-928Mhz for SST-900 and 2400-2483.5MHz for SST-2400.

1.1 Block Diagram

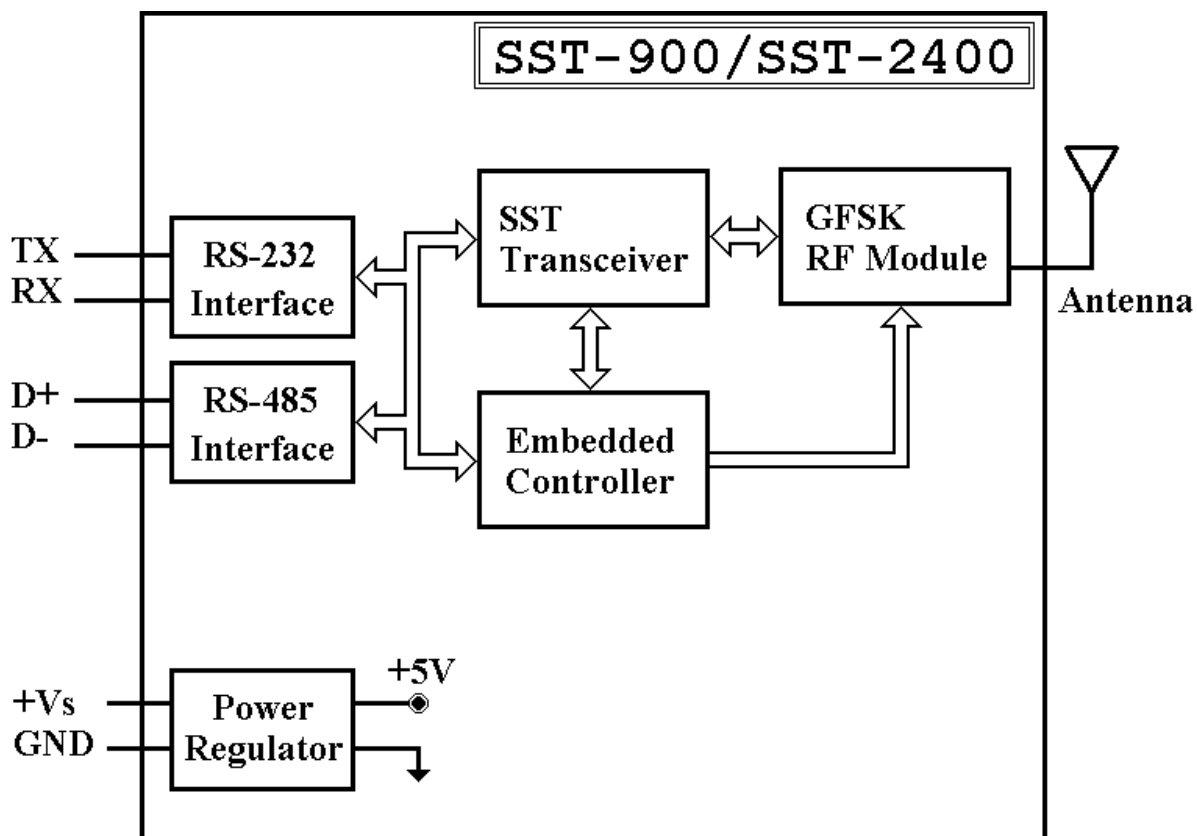

1.2 Specifications

1.2.1 SST-900EXT Wireless Radio Modem

RF Communication Transceiver

Frequency Band : 909 to 924 MHz for SST-900

Channel Spacing : 2.048 MHz (8 channels jumper select)

Output Power : 20±2 dBm

Modulation : GMSK

Time Division Duplexing

Transimition Range : Max 300M

SST Transceiver

Direct Sequency Spread Spectrum

Non-Overlapping Channels : 8 channels, jumper select (only for full-duplex operation)

Full-duplex or Half-duplex, jumper select

Synchronization or Asynchronization, jumper select

Serial Communication Interface

RS-232(TxD, RxD, GND) and RS-485(D+, D-), jumper select

Baudrate : 600bps to 57600bps, jumper select

Environment

Operating Temperature : 0°C to 50°C

Storage Temperature : -30°C to 70°C

Power Supply

Input : +10 to +30VDC, unregulated

Consumption : 1.5W



1.2.2 SST-2400EXT Wireless Radio Modem

RF Communication Transceiver

Frequency Band : 2426 to 2458 MHz

Channel Spacing : 2.048 MHz (8 channels jumper select)

Output Power : 20±2 dBm

Modulation : GMSK

Time Division Duplexing

Transimition Range : Max 300M with bundled antenna

Max 1000M with SST-2400A-3 antenna

Max 5000M with SST-2400A-12 antenna

Max 5000M with SST-2400A-13 antenna

SST Transceiver

Direct Sequency Spread Spectrum

Non-Overlapping Channels : 8 channels, jumper select (only for full-duplex operation)

Full-duplex or Half-duplex, jumper select

Synchronization or Asynchronization, jumper select

Serial Communication Interface

RS-232(TxD, RxD, GND) and RS-485(D+, D-), jumper select

Baudrate : 600bps to 57600bps, jumper select

Environment

Operating Temperature : 0°C to 50°C

Storage Temperature : -30°C to 70°C

Power Supply

Input : +10 to +30VDC, unregulated

Consumption : 1.5W



1.2.3 SST-900A External 900MHz Antenna

External antenna for SST-900EXT

Maximum Distance : 1000M

Weight : 1000g

Antenna Gain : 5dB



1.2.4 SST-2400A-3 External 2.4GHz Antenna

External antenna for SST-2400

Maximum Distance : 1000M

Weight : 150g

Antenna Gain : 3dB

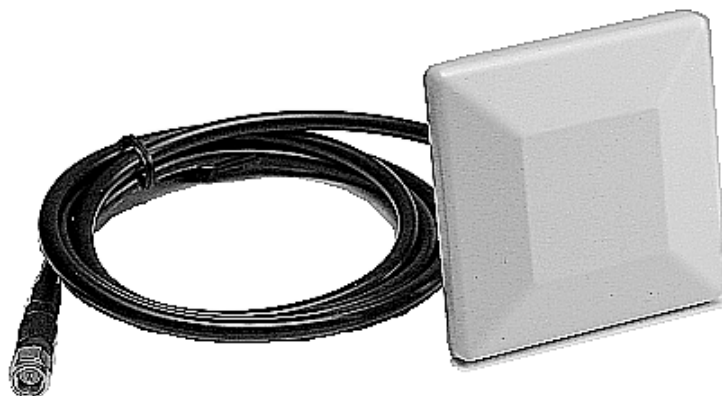

1.2.5 SST-2400A-12 External 2.4GHz Antenna

External antenna for SST-2400

Maximum Distance : 5000M

Weight : 850g

Antenna Gain : 12dB



1.2.6 SST-2400A-13 External 2.4GHz Antenna

External antenna for SST-2400

Maximum Distance : 5000M

Weight : ???g

Antenna Gain : ??dB

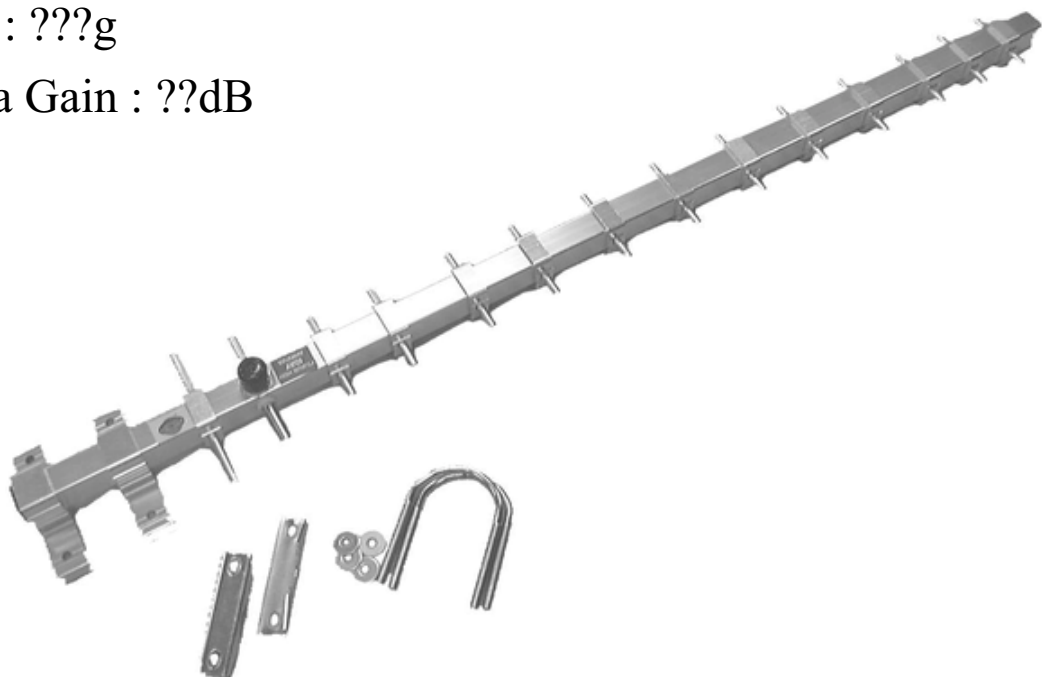

1.3 Pin Assignment

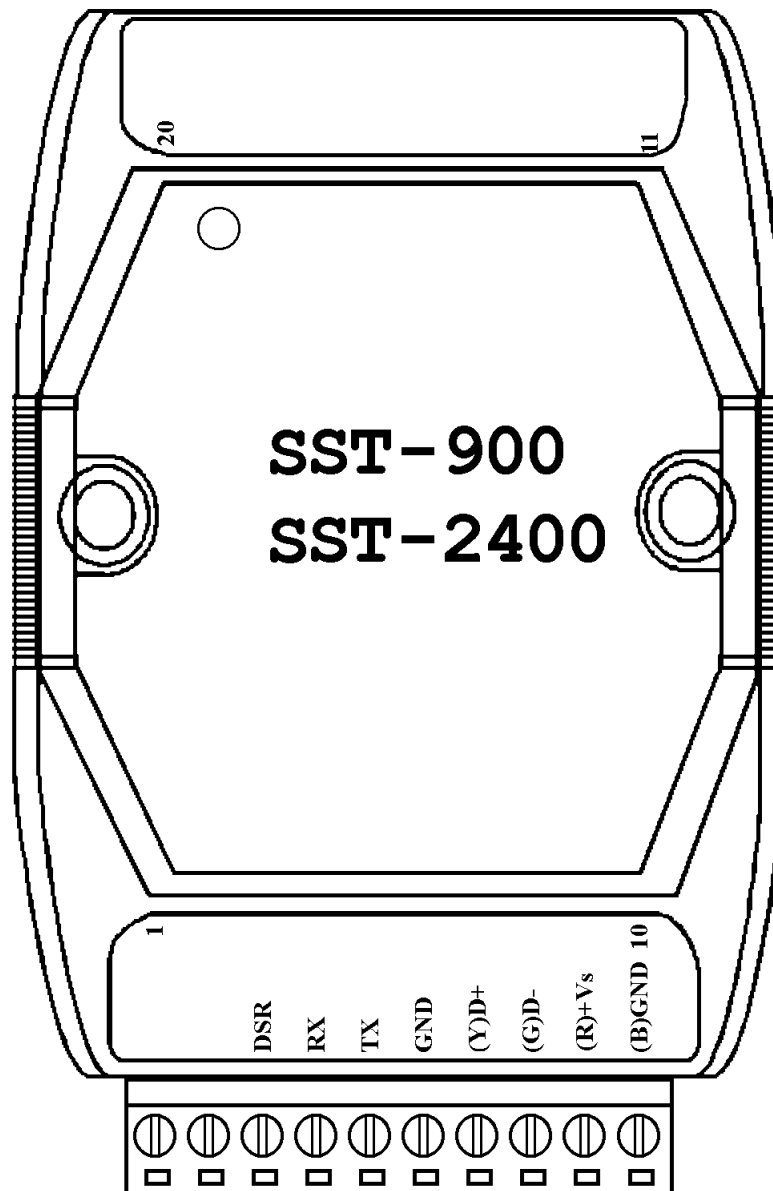

DSR	Reserved signal of diagnostic
RX	Receive of RS-232
TX	Transmit of RS-232
GND	Ground of RS-232
(Y)D+	Data+ of RS-485
(G)D-	Data- of RS-485
(R)+Vs	+10 to +30V DC power supply input
(B)GND	Ground of power supply input

1.4 Jumper Setting

Factory default jumper setting :

- (1) Channel 3 (2) Frequency 915.968/2439.936MHz
- (3) Baudrate 9600bps (4) Full-duplex
- (5) Slave (6) Synchronous
- (7) Interface RS-232

(1) Channel Select	(2) Frequency Select	(3) Baudrate Select
Channel0	909.824/2426.112MHz	600bps
Channel1	911.872/2430.720MHz	1200bps
Channel2	913.920/2435.328MHz	2400bps
Channel3	915.968/2439.936MHz	4800bps
Channel4	918.016/2444.544MHz	9600bps
Channel5	920.064/2449.152MHz	19200bps
Channel6	922.112/2453.760MHz	38400bps
Channel7	924.160/2458.368MHz	57600bps

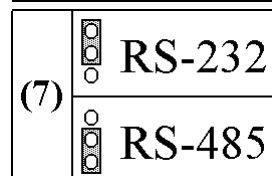
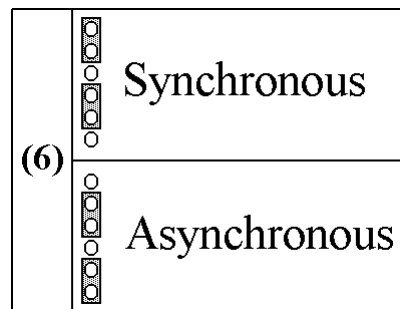
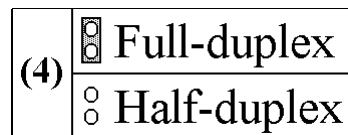
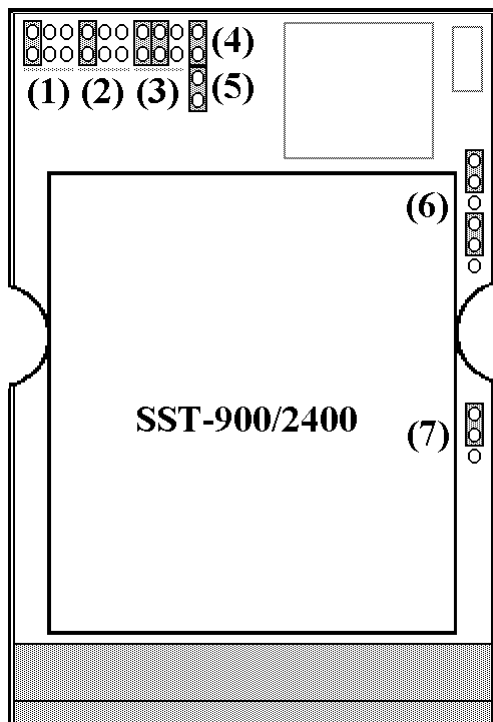

1.5 Wire Connection

Wire Connection for PC's RS-232 and SST-900/2400 :

1. The jumper(7) position in RS-232 side



2. Connect SST-900/2400's GND to CA-0910's GND, TX to TX and RX to RX.
3. Connect CA-0910's DB-9 female connector to PC's RS-232 DB-9 male connector.

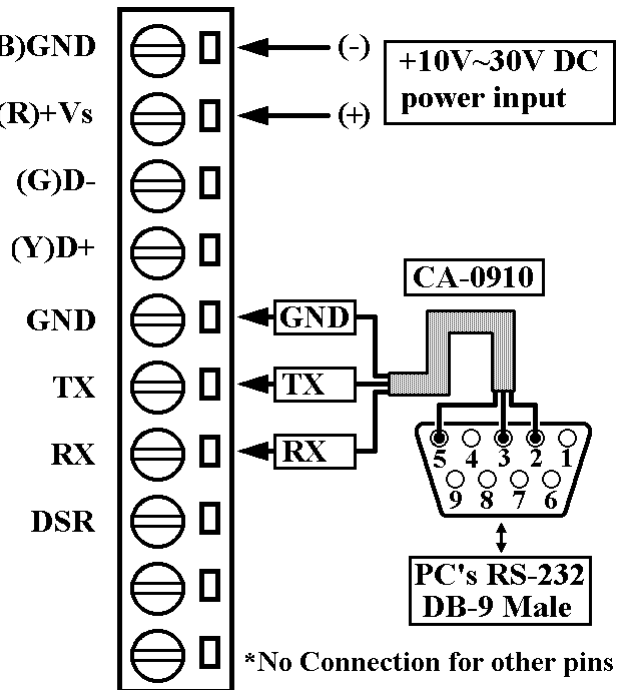

Wire Connection for I-7000 and SST-900/2400 via RS-485

1. The jumper(7) position in RS-485 side.



2. D+ of SST-900/2400 to D+ of RS-485 bus.
3. D- of SST-900/2400 to D- of RS-485 bus.

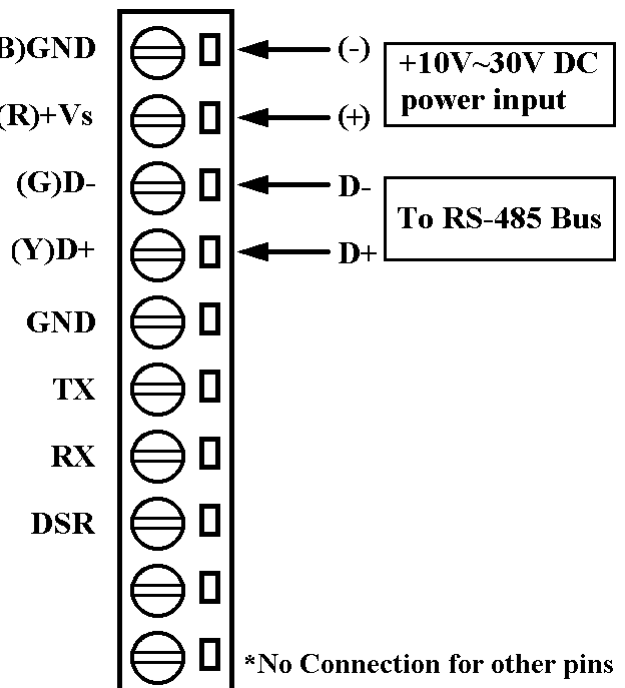

Connect SST-900EXT with SST-900A



Connect SST-2400EXT with SST-2400A-3

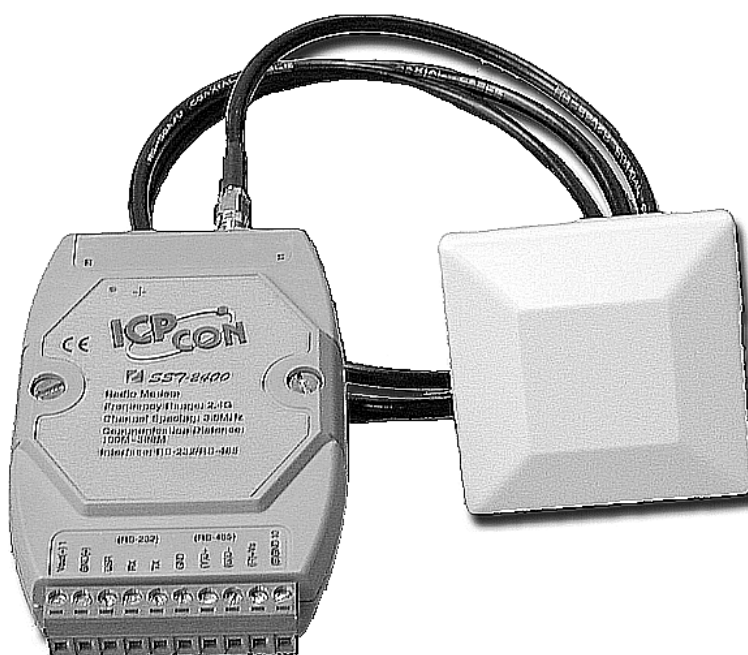

Connect SST-2400EXT with SST-2400A-12



Connect SST-2400EXT with SST-2400A-13

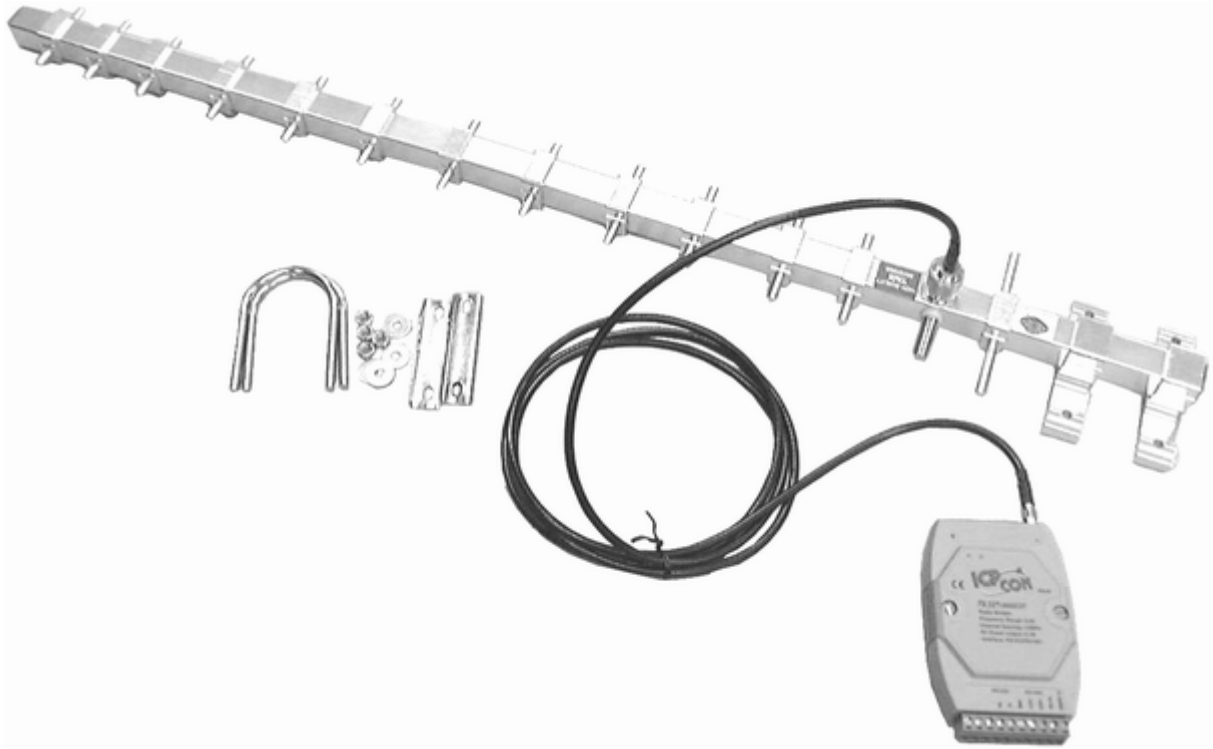

1.6 Dimension

1.6.1 SST-900EXT and SST-2400EXT

Front View

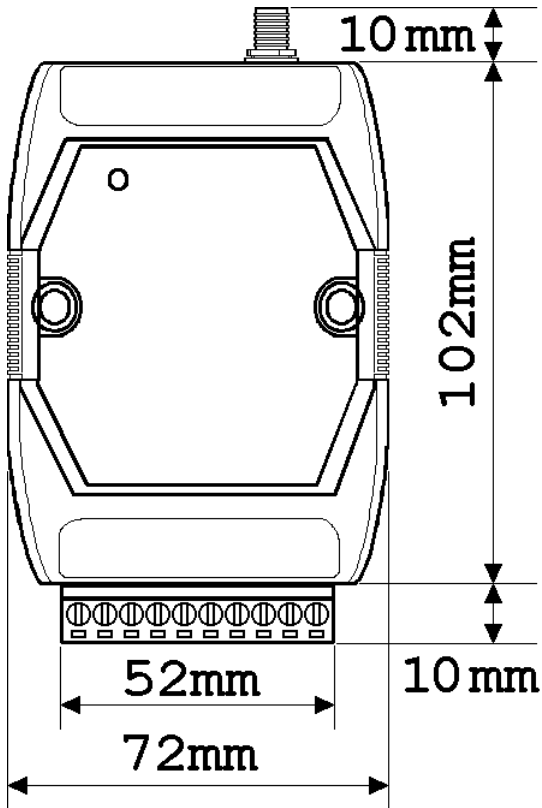

Side View

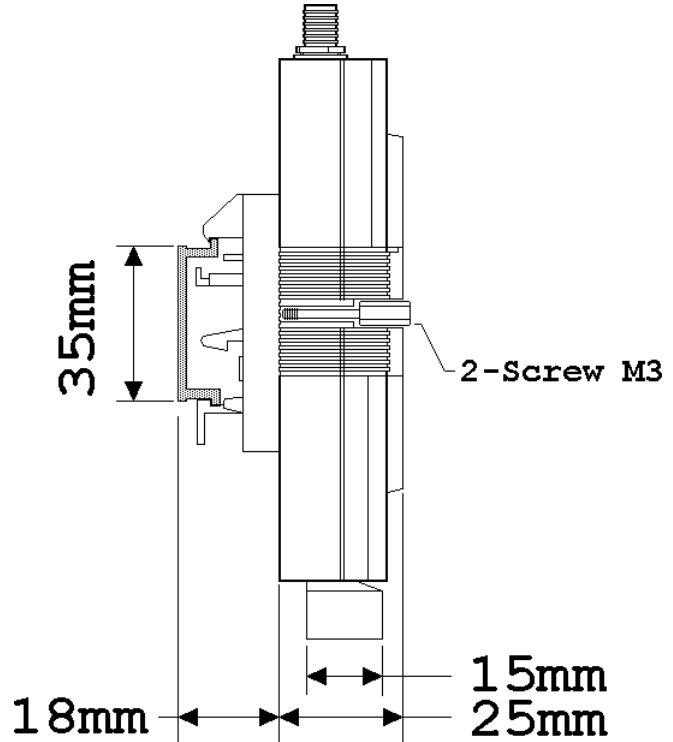

Rear View

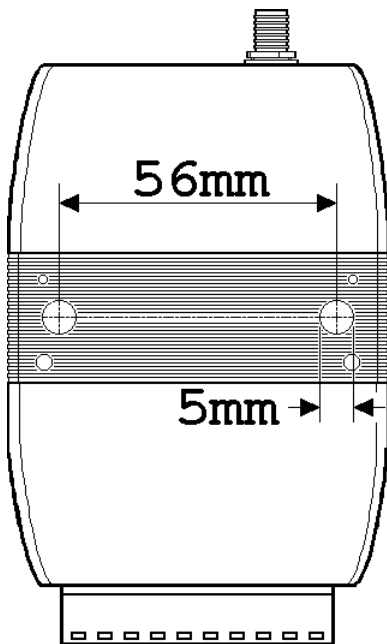

Top View

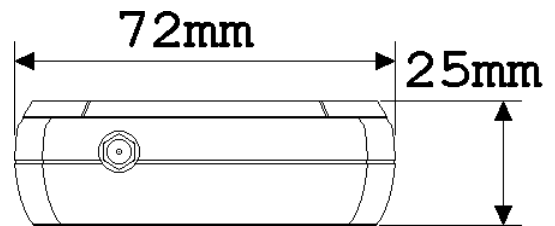

Bottom View

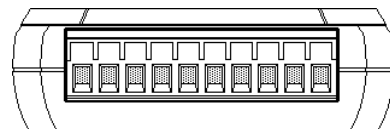

Antenna of SST-2400EXT

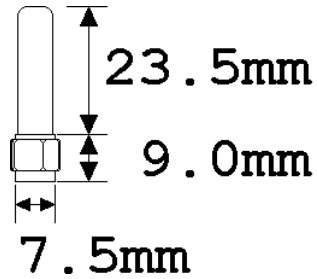

Antenna of SST-900EXT

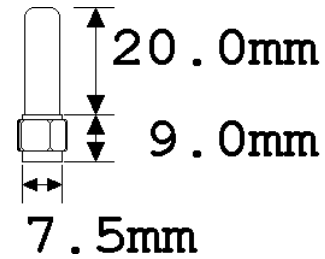

1.6.2 DIN-RAIL Mounting

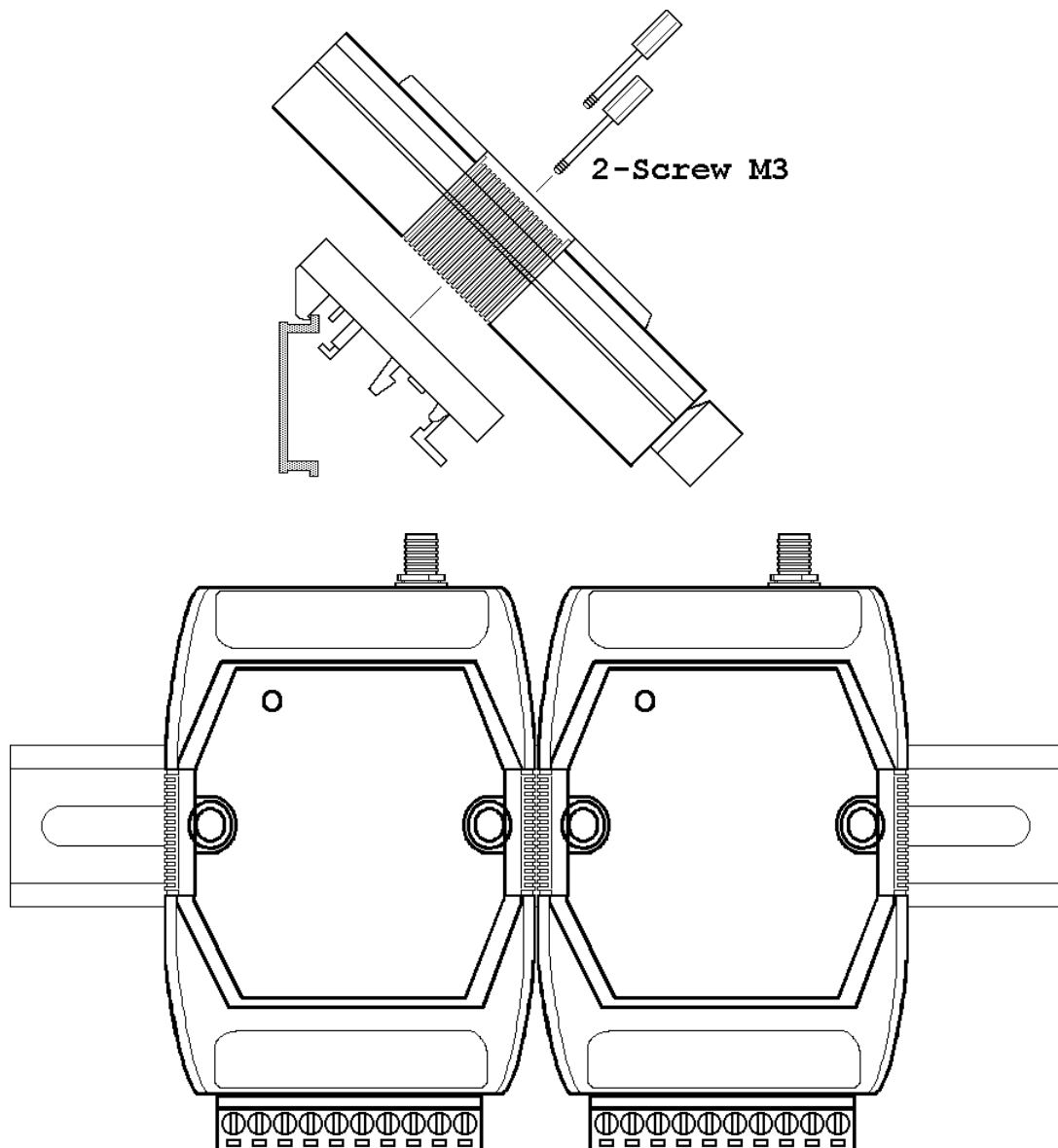

1.6.4 Pannel Mounting

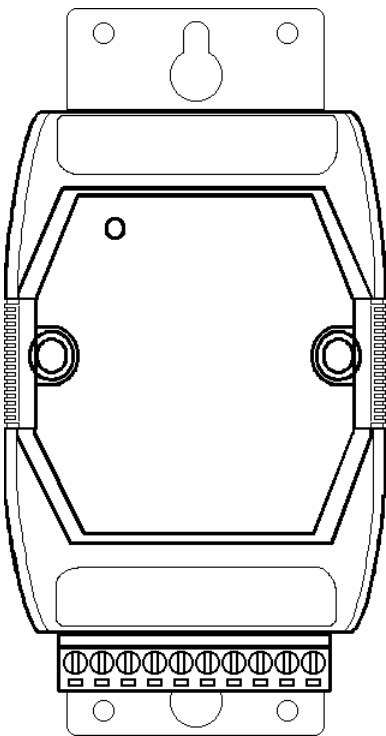
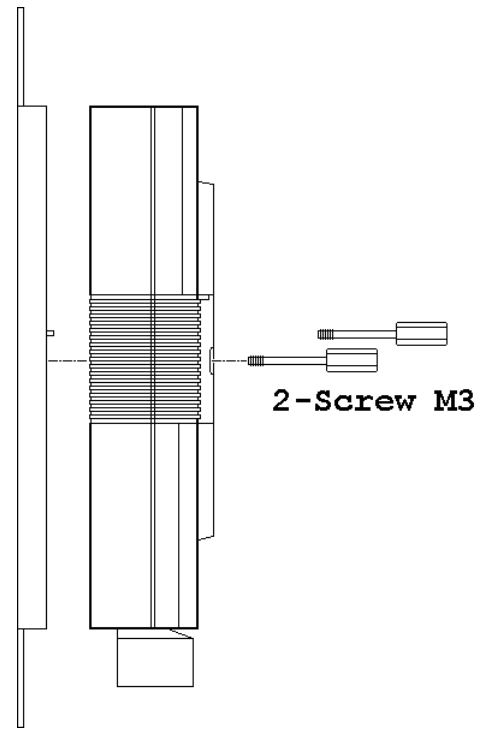
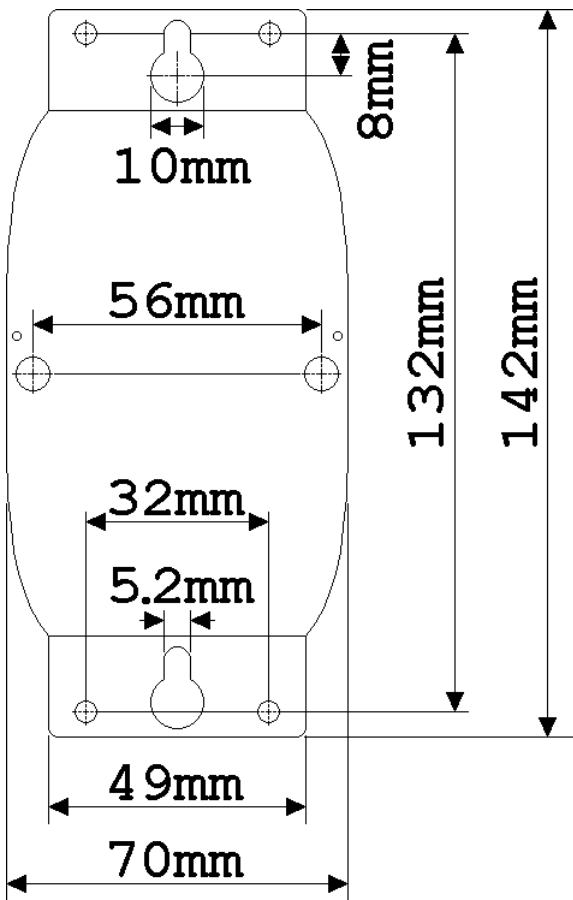

2 Configuration

2.1 Full-duplex and Half-duplex

Full-duplex is to transmit and receive data at the same time, and half-duplex is to transmit and receive data at separate time. While using full-duplex mode, only peer-to-peer operation is available. For work in multi-point operation, half-duplex is the only choice.

While working in full-duplex mode, one of the two communication modules is set as master and the other is set as slave. And both modules have same baudrate, frequency and channel select.

While working in half-duplex mode, the all modules have the same configuration. The baudrate and frequency select need all the same, and all modules select slave mode. The channel select is invalid for half-duplex mode. In half-duplex mode, only one module may transmit at the same time. If more than one module transmit data at the same time, the received data is not correct.

2.2 Synchronous and Asynchronous

In synchronous mode is that the serial data need to specified format, 1 start bit, 8 data bits, no parity bit and 1 stop bit. The data is readed in fixed data format and transimt. The receiver receive the data and output the data in fixed data format.

In asynchronous mode, the data is sampled and then transimit. And the receiver received data and regenerate the data by the sampled data. For the limitation of sampling rate of 32KHz, the data rate is limited to 14.4Kbps in order to prevent the distortion of the output data. While using asynchronous mode, only RS-232 interface may work.

2.3 Configuration Select

There are 3 different configuration of SST-900 and SST-2400 modules.

Operation Mode 1 : Full-duplex, Synchronous

Peer-to-peer communication

One master configuration and one slave configuration

Max baudrate : 19200bps

Fixed data format : 1-bit start, 8-bit data, no parity, 1-bit stop

Operation Mode 2 : Half-duplex, Synchronous

Multiple nodescommunication

All slave configuration

Max baudrate : 57600bps

Fixed data format : 1-bit start, 8-bit data, no parity, 1-bit stop

Delay between transmit and receive

Channel select is disabled

Operation Mode 3 : Full-duplex, Asynchronous

Peer-to-peer

One master configuration and one slave configuration

Max baudrate : 14400bps

Variable data format

RS-232 interface only

2.4 Operation Mode 1

Operation mode 1 is full-duplex, synchronous, fixed data format communication configuration. The mode is the most common mode for peer-to-peer communication. This mode may encode the input data streams and transmit to the other SST modules. And the other modules may decode the data streams and put into serial communication line. This may decrease the communication error rate and increase the communication stability.

Jumper Setting : Refer *Sec.1.4* for detail

- (1) : Select one channel
- (2) : Select one frequency
- (3) : Select one baudrate, max 19200 bps
- (4) : Full-duplex
- (5) : Select master or slave
- (6) : Synchronous
- (7) : RS-232 or RS-485

Benefits :

- 1. Most stable communication
- 2. Full-duplex communication

Limitation :

- 1. Fixed data format
- 2. Peer-to-peer only
- 3. Baudrates up to 19200 bps

2.5 Operation Mode 2

Operation mode 2 is half-duplex, synchronous, fixed data format communication configuration. This mode may operate for communication with two or more SST modules. While operation in this mode, all SST modules are virtually connect together with an invisible line. All communication data broadcast to every SST module. The mode is suitable to build a wireless communication network with max baudrate 57600bps. For the fewer error correction mechanism, the mode may have more communication error than operation mode 1.

Jumper Seeting : Refer *Sec.1.4* for detail

- (1) : Channel select is useless
- (2) : Select one frequency
- (3) : Select one baudrate
- (4) : Half-duplex
- (5) : Slave
- (6) : Synchronous
- (7) : RS-232 or RS-485

Benefits :

- 1. Multiple nodes communication
- 2. Baudrates up to 57600 bps

Limitation :

- 1. Fixed data format
- 2. Half-duplex only

2.6 Operation Mode 3

Operation mode 3 is full-duplex, asynchronous communication configuration. This mode is work by the way of sample and rebuild. The SST module samples the serial input (RX of RS-232) and transmit to the other SST module, and receive from RF to rebuild the serial output (TX of RS-232). For the limitation of sampling rate, the data waveform may be distortion for higher data rate.

Jumper Seeting : Refer *Sec.1.4* for detail

- (1) : Channel select is useless
- (2) : Select one frequency
- (3) : Baudrate select is useless
- (4) : Full-duplex
- (5) : Select master or slave
- (6) : Asynchronous
- (7) : RS-232

Benefits :

- 1. Full-duplex communication
- 2. Variable data formats

Limitation :

- 1. Peer-to-peer only
- 2. Baudrates up to 14400 bps
- 3. RS-232 interface only

3 Application

3.1 Peer-to-Peer Communication

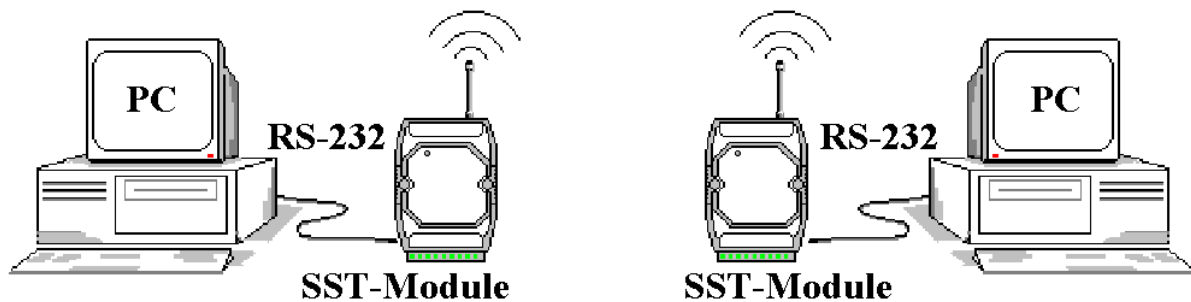

SST-900/2400 Configuration :

Interface : RS-232

Operation Mode 1 :

Full-duplex

Synchronous

Master

Baudrate : 19200bps max

SST-900/2400 Configuration :

Interface : RS-232

Operation Mode 1 :

Full-duplex

Synchronous

Slave

Baudrate : 19200bps max

Note : Basic full-duplex communication application for data format is 1-8-1 mode. Both SST-900/2400 modules need have same baudrate configuration, channel configuration and frequency configuration.

3.2 Asynchronous Connection

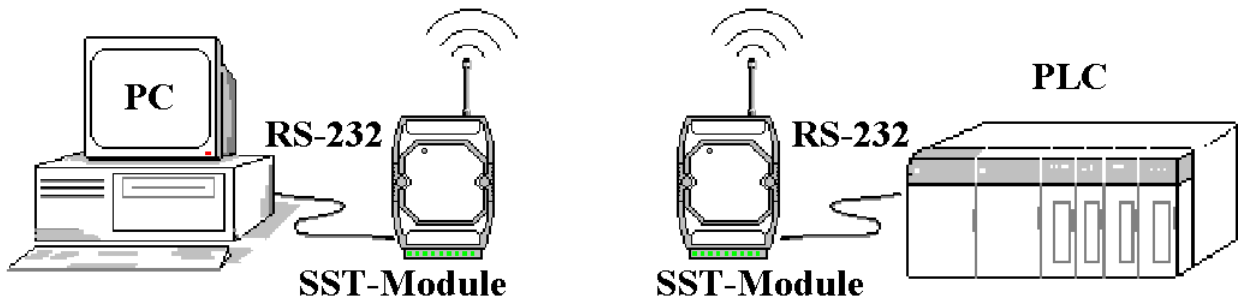

SST-900/2400 Configuration :

Interface : RS-232

Operation Mode 3 :

Full-duplex

Asynchronous

Master

Baudrate : 9600bps max

SST-900/2400 Configuration :

Interface : RS-232

Operation Mode 3 :

Full-duplex

Asynchronous

Slave

Baudrate : 9600bps max

Note : Asynchronous communication application for data format is not 1-8-1 mode. Both SST-900/2400 modules need have same baudrate configuration, channel configuration and frequency configuration.

3.3 Multiple PCs Communication

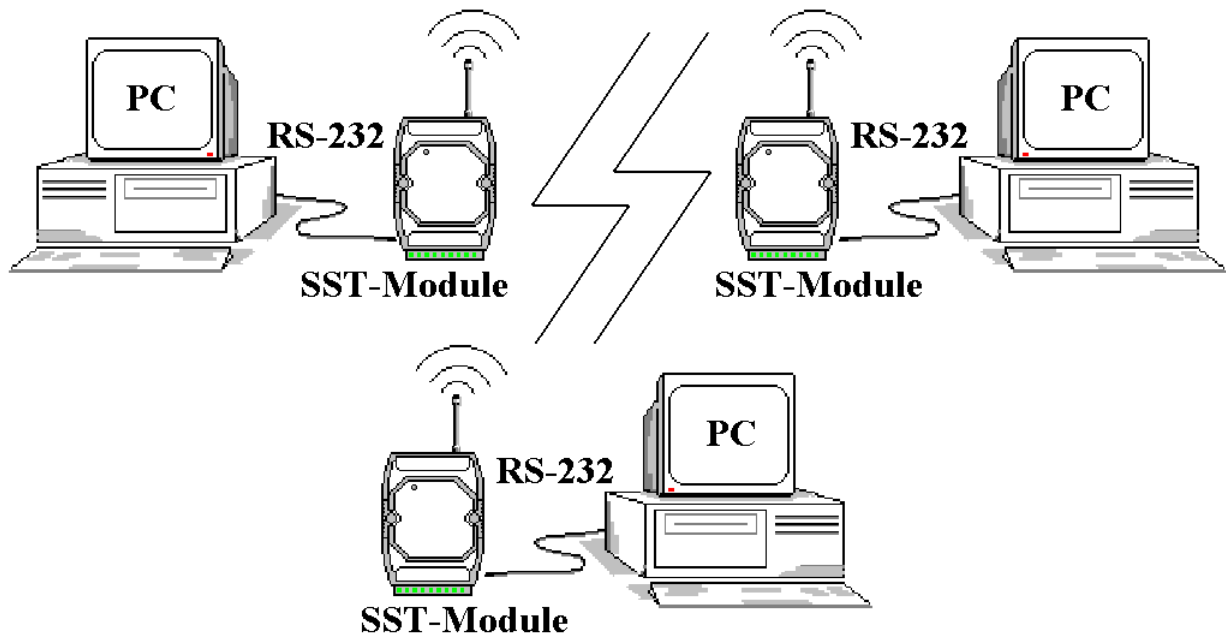

SST-900/2400 Configuration :

Interface : RS-232

Operation Mode 2 :

Half-duplex

Synchronous

Slave

Baudrate : 57600bps max

Note : Multiple PCs communication application. All SST-900/2400 modules need have same baudrate configuration and frequency configuration.

3.4 Connect I-7000 Modules

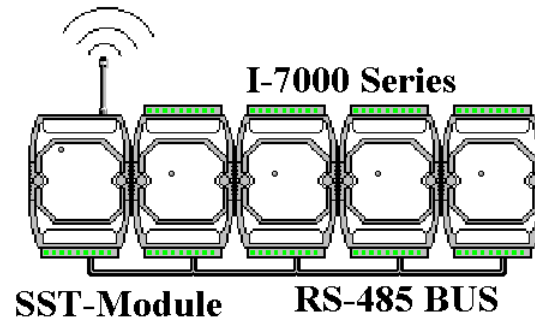
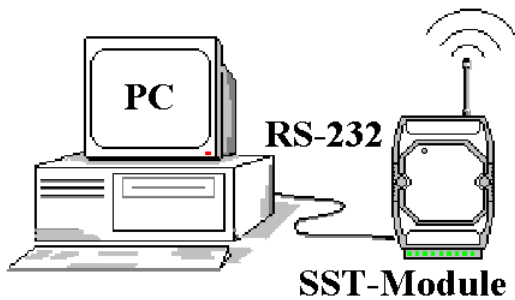

SST-900/2400 Configuration :

Interface : RS-232

Operation Mode 1 :

Full-duplex

Synchronous

Master

Baudrate : 19200bps max

SST-900/2400 Configuration :

Interface : RS-485

Operation Mode 1 :

Full-duplex

Synchronous

Slave

Baudrate : 19200bps max

Note : Connect I-7000 modules with SST-900/2400 modules. Both SST-900/2400 modules need have same baudrate configuration, channel configuration and frequency configuration.

3.5 Communication Bridge

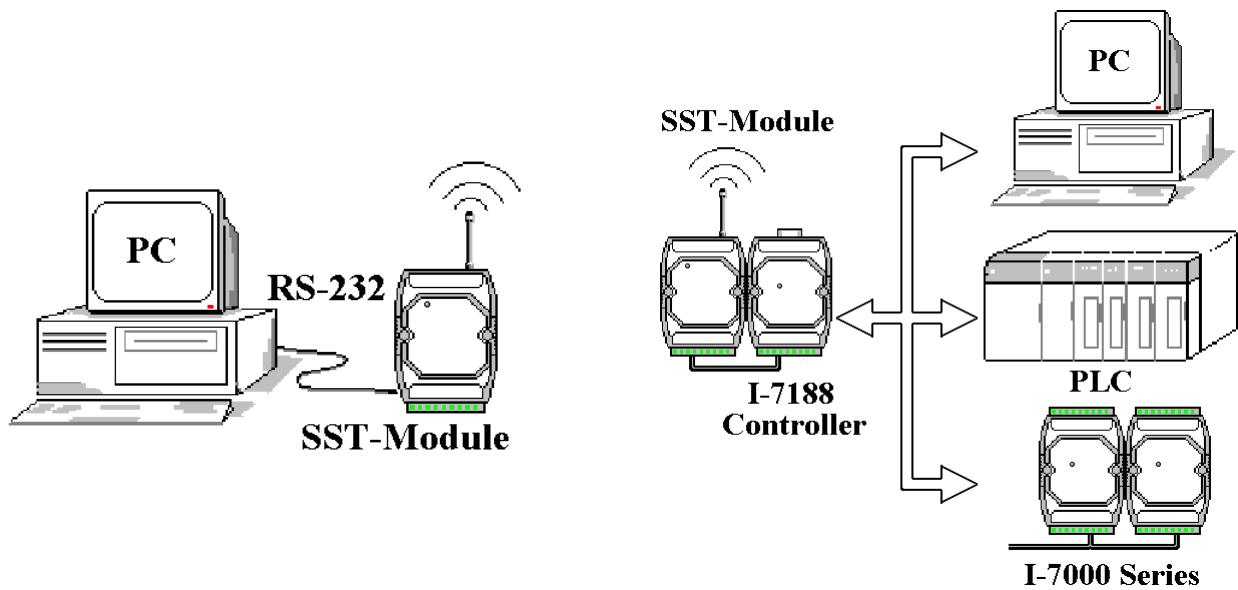

SST-900/2400 Configuration :

Interface : RS-232

Operation Mode 1 :

Full-duplex

Synchronous

Master

Baudrate : 19200bps max

SST-900/2400 Configuration :

Interface : RS-232

Operation Mode 1 :

Full-duplex

Synchronous

Slave

Baudrate : 19200bps max

Note : The I-7188 is an embedded controller with 4 serial communication ports. For different communication protocols between host PC and device, the I-7188 may work as a communication bridge or protocol converter.

3.6 Network Communication

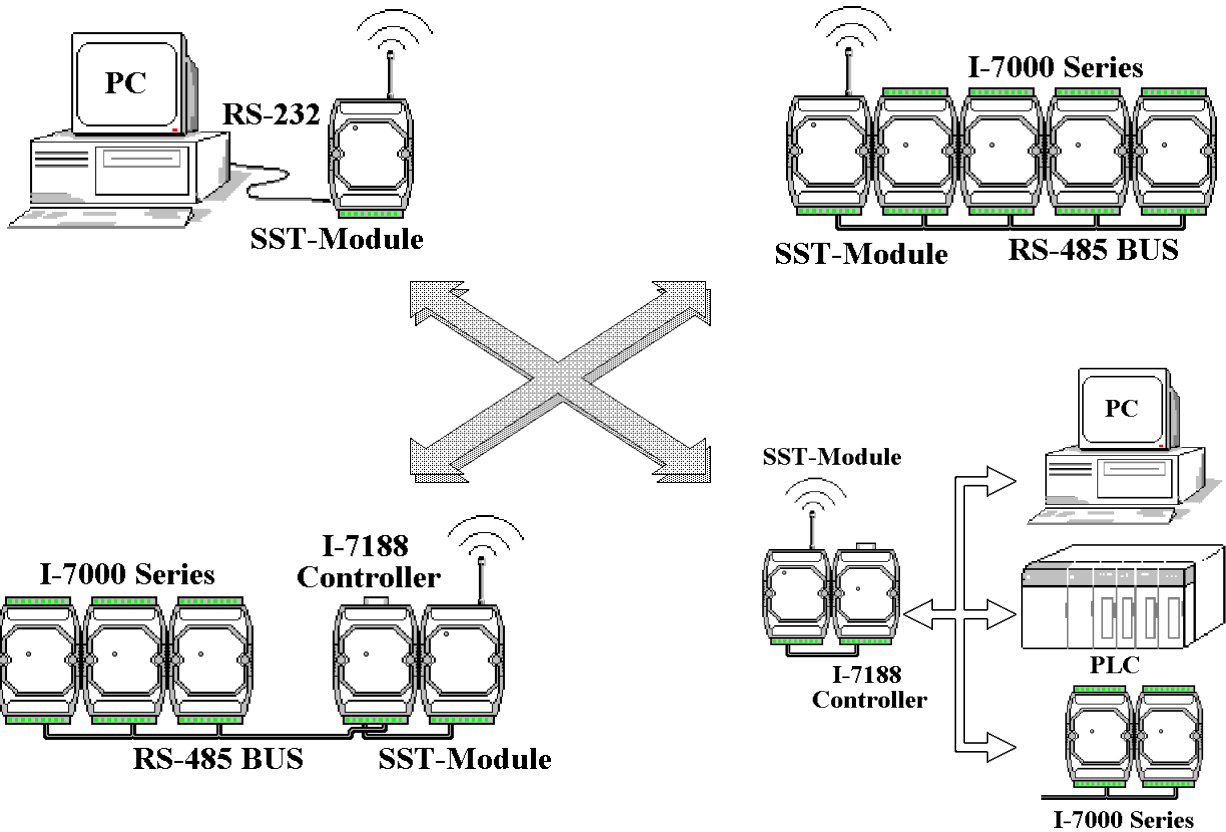

SST-900/2400 Configuration :

Interface : RS-232 or RS-485

Operation Mode 2 :

Half-duplex

Synchronous

Slave

Baudrate : 57600bps max

Note : Build wireless network via SST-900/2400 and I-7188. The network is master-slave structure, and only one master may exist at the same time.