

DOP8/16/24

Optoisolated Digital Input Board

User's Manual

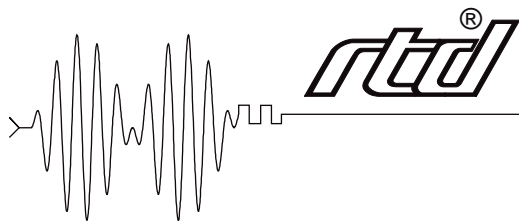

Real Time Devices USA, Inc.

"Accessing the Analog World"®

Publication No. DOP24-9742

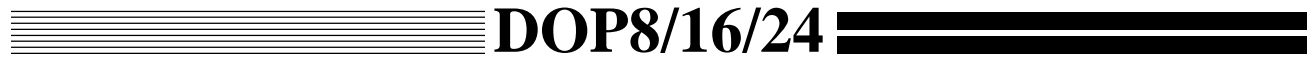

DOP8/16/24

User's Manual



REAL TIME DEVICES USA

Post Office Box 906
State College, Pennsylvania 16804
Phone: (814) 234-8087
FAX: (814) 234-5218

Published by
Real Time Devices USA, Inc.
P.O. Box 906
State College, PA 16804

Copyright © 1997 by Real Time Devices, Inc.
All rights reserved

Printed in U.S.A.

INTRODUCTION

The DOP8, DOP16, and DOP24 optoisolated digital input boards provide 8, 16, or 24 optoisolated input channels for digital signal sensing and switch monitoring applications. These boards can drive 8, 16, or 24 digital input lines and are pin-for-pin compatible with DIO24 and DIO48 boards that can be used to directly drive opto-22 racks. The DOP8/16/24 features:

- 8, 16 or 24 optoisolated digital input channels,
- LED indicators to monitor input logic status,
- Input buffered with voltage comparators,
- Adjustable threshold level,
- On-board screw terminals for easy wiring.

What Comes With Your Board

You receive the following items in your DOP8/16/24 package:

- DOP8, DOP16, or DOP24 mechanical relay output board
- User's manual

If any item is missing or damaged, please call Real Time Devices' Customer Service Department at (814) 234-8087. If you require service outside the U.S., contact your local distributor.

In addition to the items included in your DOP8/16/DOP24 package, Real Time Devices offers a full line of board accessories. Key accessories for the DOP include the TB50 terminal board and XB50 prototype/terminal board which can be connected to the daisy chain connector for prototype development and easy signal access, and the DWK-1 and DWK-2 discrete wire kits for connecting 40-pin interface boards to the 50-pin DOP board.

Using This Manual

This manual is intended to help you get your new board running quickly, while also providing enough detail about the board and its functions so that you can enjoy maximum use of its features even in the most complex applications. We assume that you already have an understanding of data acquisition principles and that you can provide the software necessary to control the DOP board.

When You Need Help

This documentation package should provide enough information for you to achieve your desired results. If you have any problems using this board, contact our Technical Support Department, (814) 234-8087, during regular business hours, eastern standard time or eastern daylight time, or send a FAX requesting assistance to (814) 234 5218. When sending a FAX request, please include your company's name and address, your name, your telephone number, and a brief description of the problem.

DOP8/16/24 DESCRIPTION

Board Layout

The DOP8/16/24 board layout is shown in Figure 1 below.

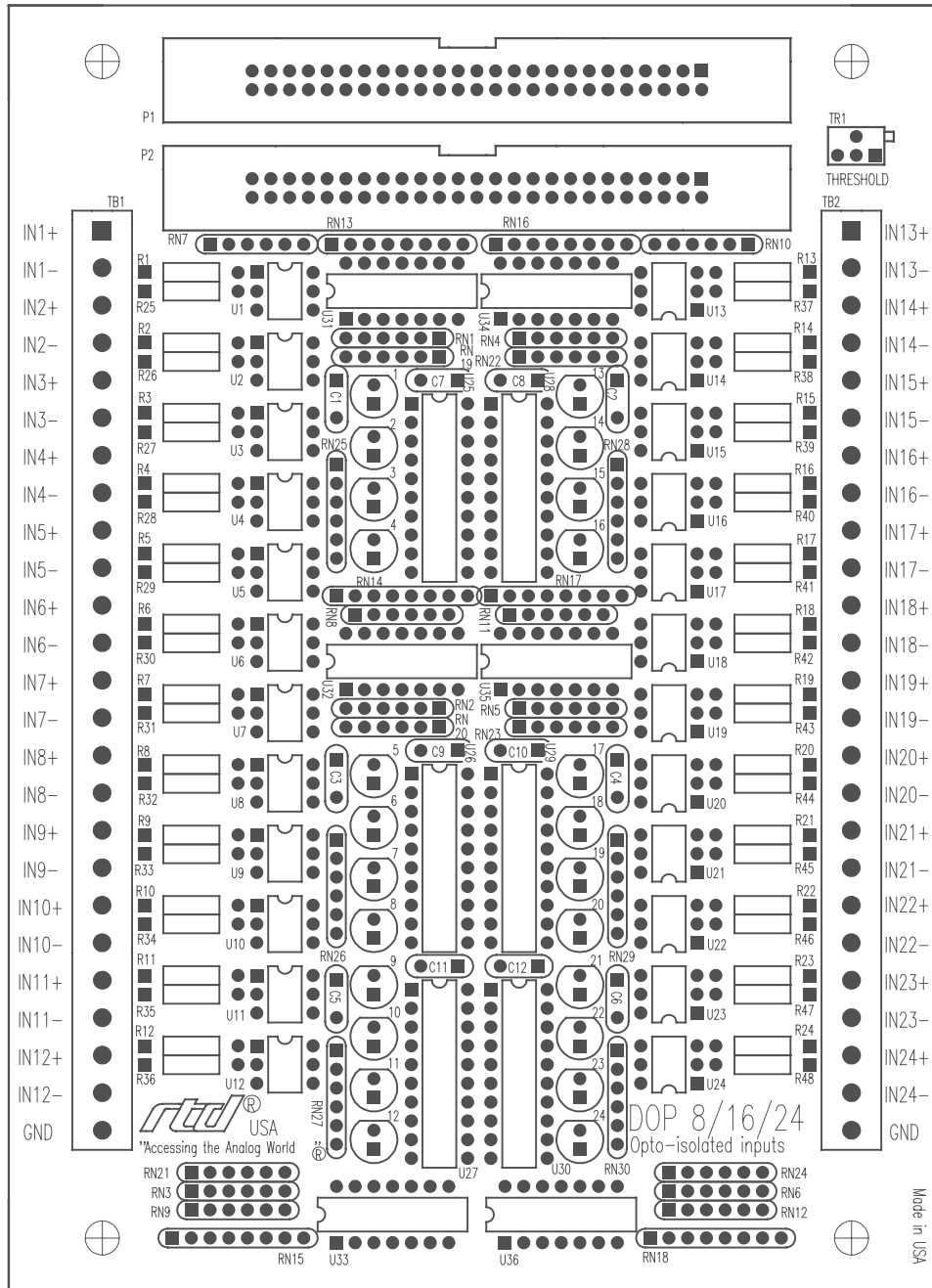

Fig. 1 — DOP8/16/24 Board Layout

Connecting to the PC Interface Board

Figure 2 shows the DOP24's P1 I/O connector pinout, with all of the pins used by the DOP24 board labeled. The DOP8 board uses DOUT0 through 7 only, and the DOP16 board uses DOUT0 through DOUT15 only. The DOP board is pin-for-pin compatible with Real Time Devices' DIO24 and DIO48 boards with pinouts for connection to opto-22 systems.

DOUT16	1	2	N.C.
DOUT17	3	4	DIGITAL GND
DOUT18	5	6	DIGITAL GND
DOUT19	7	8	DIGITAL GND
DOUT20	9	10	DIGITAL GND
DOUT21	11	12	DIGITAL GND
DOUT22	13	14	DIGITAL GND
DOUT23	15	16	DIGITAL GND
DOUT8	17	18	DIGITAL GND
DOUT9	19	20	DIGITAL GND
DOUT10	21	22	DIGITAL GND
DOUT11	23	24	DIGITAL GND
DOUT12	25	26	DIGITAL GND
DOUT13	27	28	DIGITAL GND
DOUT14	29	30	DIGITAL GND
DOUT15	31	32	DIGITAL GND
DOUT0	33	34	DIGITAL GND
DOUT1	35	36	DIGITAL GND
DOUT2	37	38	DIGITAL GND
DOUT3	39	40	DIGITAL GND
DOUT4	41	42	DIGITAL GND
DOUT5	43	44	DIGITAL GND
DOUT6	45	46	DIGITAL GND
DOUT7	47	48	DIGITAL GND
+5 VOLTS	49	50	DIGITAL GND

Fig. 2 — P1 I/O Connector Pin Assignments

Connecting to the Signal Sources

The DOP8/16/24 is connected to a signal source as shown in Figure 3. For example, the circuit may be used to detect closure of a switch. The positive side of the switch would be connected to the positive (+) terminal on the DOP board and the negative, or ground, side would be connected to the negative (-) terminal. The channel output is connected to a digital input line on your digital I/O board through DOP8/16/24 connector P1.

If your interface board's digital I/O is provided by an 8255 programmable peripheral interface (PPI), then you must set up the lines that routed through the optoisolation circuitry on the DOP as mode 0 inputs. The interface board manual tells you how to set up the PPI.

TB1 and TB2 are 25-terminal miniature screw terminal strips which let you easily connect and disconnect the digital inputs from external devices. TB1 and TB2 also provide ground terminals for your convenience.

DOP8/16/24 Circuitry

Figure 3 shows a single channel on the DOP board. All channels are identical. To show how the circuit operates, let's use our example of detecting switch closure. When the switch is open, there is no current flow through the input circuit, the DOP LED is off, and the digital output is low, or 0. When the switch is closed, a current is generated in the input circuit, the LED lights, and the digital output goes high, or to 1. The input signal is buffered with a voltage comparator to allow flexible signal conditioning.

A threshold trimpot, TR1, is included on the board to adjust the threshold level for all channels. The level is factory set at about 1 milliampere. In a noisy environment, you may want to adjust the threshold level to a higher setting to achieve the required noise immunity and prevent false readings. This is done by connecting an input circuit, such as one using a 5-volt supply and appropriate series resistance, and adjusting TR1 until the LED for channel 1 turns on at a higher input current level, such as 5 or 10 milliamperes.

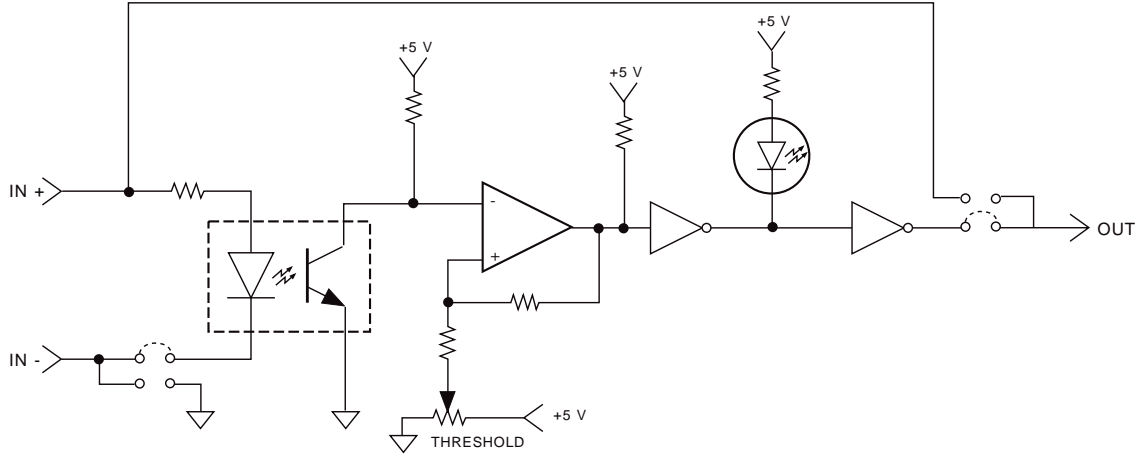

Fig. 3 — DOP8/16/24 Channel Circuit Diagram

APPENDIX A

DOP8/16/24 SPECIFICATIONS

DOP8/16/24 Characteristics Typical @ 25° C

Input Circuitry

- Number of channels 8, 16 or 24
- Type of optoisolator 4N25
- Input current, per channel 80 mA, max
- Buffering voltage comparator
- Threshold voltage/current 1.5 volts/1 mA, adjustable
- Maximum input voltage 1500 Vdc

Current Requirements

- +5 volts (inputs = 0) 85 mA

Power Requirements

- +5 volts From PC bus

Connectors

- Two 50-pin box headers

Screw Terminals

- TB1 and TB2 - 25-terminal
- 22-12 AWG wire

Size

- 6.875"L x 5.0"W (175mm x 127mm)

APPENDIX B

DOP24 PINOUT

DOP24 Pinout:

DOUT16	①	②	N.C.
DOUT17	③	④	DIGITAL GND
DOUT18	⑤	⑥	DIGITAL GND
DOUT19	⑦	⑧	DIGITAL GND
DOUT20	⑨	⑩	DIGITAL GND
DOUT21	⑪	⑫	DIGITAL GND
DOUT22	⑬	⑭	DIGITAL GND
DOUT23	⑮	⑯	DIGITAL GND
DOUT8	⑰	⑱	DIGITAL GND
DOUT9	⑲	⑳	DIGITAL GND
DOUT10	㉑	㉒	DIGITAL GND
DOUT11	㉓	㉔	DIGITAL GND
DOUT12	㉕	㉖	DIGITAL GND
DOUT13	㉗	㉘	DIGITAL GND
DOUT14	㉙	㉚	DIGITAL GND
DOUT15	㉛	㉜	DIGITAL GND
DOUT0	㉝	㉞	DIGITAL GND
DOUT1	㉟	㊱	DIGITAL GND
DOUT2	㊲	㊳	DIGITAL GND
DOUT3	㊴	㊵	DIGITAL GND
DOUT4	㊶	㊷	DIGITAL GND
DOUT5	㊸	㊹	DIGITAL GND
DOUT6	㊺	㊻	DIGITAL GND
DOUT7	㊼	㊽	DIGITAL GND
+5 VOLTS	㊾	㊿	DIGITAL GND

APPENDIX C

WARRANTY

LIMITED WARRANTY

Real Time Devices, Inc. warrants the hardware and software products it manufactures and produces to be free from defects in materials and workmanship for one year following the date of shipment from REAL TIME DEVICES. This warranty is limited to the original purchaser of product and is not transferable.

During the one year warranty period, REAL TIME DEVICES will repair or replace, at its option, any defective products or parts at no additional charge, provided that the product is returned, shipping prepaid, to REAL TIME DEVICES. All replaced parts and products become the property of REAL TIME DEVICES. **Before returning any product for repair, customers are required to contact the factory for an RMA number.**

THIS LIMITED WARRANTY DOES NOT EXTEND TO ANY PRODUCTS WHICH HAVE BEEN DAMAGED AS A RESULT OF ACCIDENT, MISUSE, ABUSE (such as: use of incorrect input voltages, improper or insufficient ventilation, failure to follow the operating instructions that are provided by REAL TIME DEVICES, "acts of God" or other contingencies beyond the control of REAL TIME DEVICES), OR AS A RESULT OF SERVICE OR MODIFICATION BY ANYONE OTHER THAN REAL TIME DEVICES. EXCEPT AS EXPRESSLY SET FORTH ABOVE, NO OTHER WARRANTIES ARE EXPRESSED OR IMPLIED, INCLUDING, BUT NOT LIMITED TO, ANY IMPLIED WARRANTIES OF MERCHANTABILITY AND FITNESS FOR A PARTICULAR PURPOSE, AND REAL TIME DEVICES EXPRESSLY DISCLAIMS ALL WARRANTIES NOT STATED HEREIN. ALL IMPLIED WARRANTIES, INCLUDING IMPLIED WARRANTIES FOR MERCHANTABILITY AND FITNESS FOR A PARTICULAR PURPOSE, ARE LIMITED TO THE DURATION OF THIS WARRANTY. IN THE EVENT THE PRODUCT IS NOT FREE FROM DEFECTS AS WARRANTED ABOVE, THE PURCHASER'S SOLE REMEDY SHALL BE REPAIR OR REPLACEMENT AS PROVIDED ABOVE. UNDER NO CIRCUMSTANCES WILL REAL TIME DEVICES BE LIABLE TO THE PURCHASER OR ANY USER FOR ANY DAMAGES, INCLUDING ANY INCIDENTAL OR CONSEQUENTIAL DAMAGES, EXPENSES, LOST PROFITS, LOST SAVINGS, OR OTHER DAMAGES ARISING OUT OF THE USE OR INABILITY TO USE THE PRODUCT.

SOME STATES DO NOT ALLOW THE EXCLUSION OR LIMITATION OF INCIDENTAL OR CONSEQUENTIAL DAMAGES FOR CONSUMER PRODUCTS, AND SOME STATES DO NOT ALLOW LIMITATIONS ON HOW LONG AN IMPLIED WARRANTY LASTS, SO THE ABOVE LIMITATIONS OR EXCLUSIONS MAY NOT APPLY TO YOU.

THIS WARRANTY GIVES YOU SPECIFIC LEGAL RIGHTS, AND YOU MAY ALSO HAVE OTHER RIGHTS WHICH VARY FROM STATE TO STATE.

