

Intellio C320^{Turbo}/PCI User's Manual

*An Advanced Professional Intelligent Multiport System for PCI bus with
Desktop and Rackmount options*

Nov. 1999 (3rd Edition)

The content of this manual is also available in CD-ROM and at Moxa Web Site.



Moxa Technologies Co., Ltd.

Tel: +866-2-8665-6373

Fax: +886-2-8665-6372

www.moxa.com

support@moxa.com.tw

Intellio C320Turbo/PCI User's Manual

The product described in this manual is furnished under a license agreement and may be used only in accordance with the terms of the agreements.

Copyright Notice

Copyright © 1999 Moxa Technologies Co., Ltd.
All rights reserved.
Reproduction in any form without permission is prohibited.

Trademarks

MOXA is a registered trademark of Moxa Technologies Co., Ltd.
All other trademarks or registered marks in this manual belong to their respective manufacturers.

Disclaimer

Information in this document is subject to change without notice and does not represent a commitment on the part of Moxa.

Moxa provides this document “as is”, without warranty of any kind, either expressed or implied, including, but not limited to, the particular purpose. Moxa may make improvements and/or changes in this manual or in the product(s) and/or the program(s) described in this manual at any time.

Information provided in this manual is intended to be accurate and reliable. However, Moxa Technologies assumes no responsibility for its use, or for any infringements of rights of the fourth parties which may result from its use.

This product could include technical or typographical errors. Changes are periodically made to the information herein; these changes may be incorporated in new editions of the publication.

MOXA Internet Services

Customer's satisfaction is always our number one concern. To ensure that customers get the full benefit of our services, Moxa Internet Services have been built for technical support, product inquiry, new driver update, user's manual update, etc.

The followings are the services we provide.

E-mail for technical support

address: *support@moxa.com.tw*

FTP site for free driver update

address: *ftp.moxa.com*

or

ftp.moxa.com.tw

user ID: *ftp*

password: *your_email_address*

World Wide Web (WWW) Site for product info

address: *www.moxa.com*

or

www.moxa.com.tw

About This Manual

This manual is composed of six Chapters and one Appendix. This manual is written for installer, system administrator and software programmer.

If you are a first-time installer and system administrator, we recommend you to go through the whole manual except Chapter 4.

If you are a software programmer, you may refer to Chapter 4 “Serial Programming Tools”.

If you need cable wiring information, please see Chapter 5 “Connection Option (Opt8x) and Cable Wiring”.

If you encounter any problem during installation, please refer to Chapter 6 “Troubleshooting”.

 In this manual, C320Turbo Series refers to C320Turbo and C320Turbo/PCI.

Chapter 1 Introduction

Overview and features for C320Turbo/PCI are described. Also check list and overall installation guide.

Chapter 2 Hardware Installation

Hardware installation for C320Turbo/PCI .

Chapter 3 Software Installation

This Chapter details the software installation, configuration, driver loading/unloading, driver upgrade and removal for various operating systems: Windows NT, Windows 95/98 and UNIX.

Chapter 4 Serial Programming Tools

This Chapter roughly describes the programming tools for various O.S. platforms, including PComm under Windows NT, Windows 95/98 and standard UNIX system calls.

Chapter 5 Connection Option and Cable Wiring

This Chapter describes the RS-232/422 cable wiring for the connection options.

Chapter 6 Troubleshooting

This Chapter describes the problems and possible answers for C320Turbo/PCI.

Appendix

Specification details, PCI, Dual-Ported RAM, and UART are described.

Table of Contents

Introduction	1-1
Overview	1-1
Features.....	1-4
Check List.....	1-5
Installation Guide	1-6
Hardware Installation.....	2-1
Installing the Intellio C320Turbo/PCI Control Board	2-1
Installing the External Modules	2-2
Installing the CPU and UART Modules (Desktop).....	2-2
Installing the Basic and Extensive Modules (Rackmount).....	2-5
Operating LED Indicators.....	2-8
Mix of Various UART Modules	2-10
Software Installation.....	3-1
Windows NT	3-1
Installing Driver	3-2
Configuring Board and Port	3-7
Adding/Removing Board.....	3-9
Updating Driver.....	3-9
Removing Driver	3-9
Windows 95/98	3-10
Installing Driver	3-10
Configuring Board and Port	3-19
Updating driver	3-23
Removing driver	3-23
UNIX	3-24
Installing Driver	3-24
MOXA TTY Device Naming Convention.....	3-27
Administration Utility - mxadm	3-28
Checking Board Initialization Status	3-34
Setting MOXA Ports to Terminal	3-34

Serial Programming Tools.....	4-1
Windows NT and Windows 95/98	4-1
Installation.....	4-1
PComm Programming Library.....	4-2
Utilities	4-2
UNIX	4-5
Programming the MOXA Ports.....	4-5
Extended UNIX ioctl() Commands	4-5
Utilities	4-11
Connection Option and Cable Wiring.....	5-1
RS-232 Cable Wiring for C32045T/C32047T/C32071T	5-1
RS-422 Cable Wiring for C32061T/C32065T	5-7
RS-232 Cable Wiring for C32080T/81T/82T/83T & CN20040	5-10
C32020T Link Cable	5-14
Troubleshooting	6-1
General Troubleshooting.....	6-1
Windows NT	6-5
Windows 95/98	6-7
UNIX	6-8
Technical Reference.....	A-1
Specifications.....	A-1
PCI.....	A-5
Dual-Ported RAM.....	A-5
TI550C in UART/Basic/Extensive Modules	A-6

Introduction

This manual covers both the hardware and software installation and configuration of **C320Turbo/PCI**, which is the member of the **Intellio** Family. In addition, the professional serial comm tools, **PComm** under Windows NT and Windows 95/98 and extended UNIX system calls, and utilities are introduced.

Overview

The excellent features, described below, make **Intellio C320Turbo/PCI** the best choice for medium to large-scale data communication systems from 8 to 128 serial ports.

Intellio - The Intelligent 8-32 Port Serial I/O Solution

The **Intellio C320Turbo/PCI** is an intelligent dual-CPU high-speed expandable multi-serial communication controller, which aims to gain higher speed, achieve better performance and lessen the load of the host system.

Port Expandable

The **Intellio C320Turbo/PCI** is composed of a Control Board, a DB25 to DB25 cable, some external modules. The **Intellio C320Turbo/PCI** supports expandability from 8 to 32 ports for a single PC slot. Up to **128** ports could be used in the PC with four **Intellio C320Turbo/PCI** installed.

PCI Solution

The board complies with PCI Spec. 2.1 and has neither switch nor jumper. Hardware configuration for the IRQ number and memory addresses is automatically assigned by PCI BIOS. Hence, it is a must to have the board plugged first before installing software driver. For more PCI information, see appendix.

Low Host Processor Overhead

The Intellio C320Turbo/PCI is equipped with two high performance processors (TMS320) on both the Control Board and the CPU/Basic Module and 512KB on-board memory to relieve the host's CPU workload of all data and I/O handling tasks. The memory buffer holds transmitted and received data to prevent data loss.

ASIC Design, Compact Size

The Intellio C320Turbo/PCI is also equipped with MOXA custom-designed ASIC chip, which replaces lots of conventional IC and hence reduces the board to half-size, increases the operation performance, and lowers the failure rate of the board.

Distance Extensible

Normally, a standard 2-meter DB25 to DB25 cable with 25 signal pins links the Control Board to the external module. However, for the purpose of extending the distance between Control Board and external modules to above **2 m** and up to **100 m (328 ft)** or improving power insufficiency problem of the PC host, external power and the cable specially fabricated with only 10 signal pins should be used as illustrated in chapter 2 and chapter 5.

Versatile Connection Options

There are two connection options, **Desktop** and **Rackmount**, for the external modules to meet various connection requirements. For Desktop option, CPU Module and UART Modules are provided. For Rackmount option, Basic Module and Extensive Modules are provided with rack mount capability. Besides, you may choose flexibly from modules with DB25/RJ45, male/female, or RS-232/RS-422.

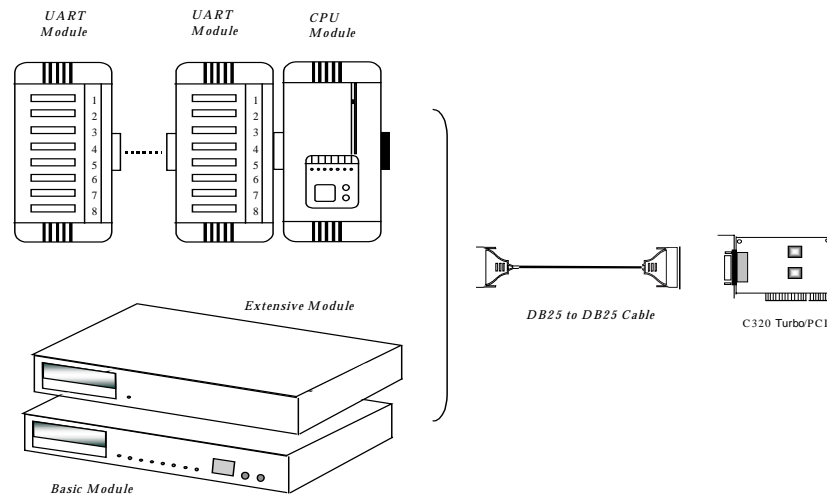

Surge/Isolation Protection

To prevent the boards from damage caused by lightning or high potential voltage, **TVSS** (Transient Voltage Surge Suppressor) and high potential difference protector technologies are introduced in some connection options to protect the multiport controller. This is critical to harsh environment such as factory, severe weather such as lightning, or other high interference situations.

Status Indicator

The status of the communication lines is displayed on a row of diagnostic LED indicators on the front panel of the external module, including TxD, RxD, DTR, DSR, RTS, CTS, and DCD signals.

Major Operating System Support

It supports most popular O.S. platforms like Windows NT, Windows 95/98, SCO UNIX/OpenServer, UNIX SVR4.2, Linux. **MOXA device drivers** feature easy installation, configuration and better performance. In this manual, chapters for **MOXA Windows NT, Windows 95/98, and UNIX** device drivers are included. For other systems not mentioned, please contact Moxa dealer/distributor or Moxa or visit the **MOXA Web** site for more information about newly available device drivers.

Powerful Serial Comm Developing Tools

For application development, MOXA provides the easy-to-use while powerful serial communication library, including **PComm** under Windows NT, Windows 95/98 and extended UNIX system calls. You can use this library to develop applications with programming languages like Visual C++, Visual Basic, Borland C++, Borland Delphi, UNIX C, etc. Utilities, such as monitor, terminal emulator, and diagnostics, are included for debugging or monitoring the communication status or for terminal emulation or file transferring.

Easy Installation

No matter hardware or software, installation are made as easy as possible. Follow the installation guide to install and configure the hardware and the driver. Then, you can start to use Intellio C320Turbo/PCI to transmit/receive data to/from the connected devices, such as terminals, modems and printers, with ready-made or self-written application programs.

Broad Applications

The Intellio C320Turbo/PCI is suitable for many applications. Here are a few:

- Internet/Intranet Connection
- Remote Access Application
- Multi-user Application
- Industrial Automation
- Office Automation
- Telecommunication
- PC-based (vending) Machine or Kiosk System
- Point-of-Sale (POS) System

Features

The following is a summary of all the outstanding features of Intellio C320 Turbo/PCI:

- ❖ High speed serial communication—Up to 460.8 Kbps
- ❖ Low host CPU's overhead—Dual RISC processor architecture
- ❖ Reliability—On-chip hardware flow control guarantees no data loss
- ❖ Modular expandability—Easy to add ports for a single PC slot
- ❖ Supports full communication status display for each port
- ❖ Long range extensibility—Easy for long distance cable layout

- ❖ Rack mountable – Industrial standard 19” rack
- ❖ Supports most popular OS – Windows NT, Windows 95/98, UNIX, Linux
- ❖ Friendly user interface for configuration and utilities
- ❖ Powerful but easy serial programming library and illustrative examples

Check List

Upon unpacking Intellio C320Turbo/PCI package, you should find the following items:

- ❖ One Intellio C320Turbo/PCI Control Board
- ❖ One CPU Module or Basic Module
- ❖ One 2-meter DB25 to DB25 cable for connecting Control Board and CPU/Basic Module. This item may not be needed if long range extension kit is purchased
 - ❖ For Desktop option, at least one and up to four 8-port RS-232/RS-422 female/male UART Module(s). For Rackmount option, up to 32 ports of combination of 8-port or 16-port RS-232 Basic/Extensive Module(s).
 - ❖ For Rackmount option, DB-37 to DB-37 cable(s) for connecting Basic/Extensive Modules, if Extensive Module is used
 - ❖ For Rackmount option, one 1.5-meter RJ-45 to male DB25 RS-232 cable for testing
- ❖ Device driver diskettes:
 - Windows NT and Windows 95/98 Version 4.9 or above × 1
 - PCComm Lite** Version 2.2 or above × 1
 - UNIX Version 4.10 or above × 1
- ❖ This Intellio C320Turbo/PCI User's Manual
- ❖ Fixing Kit for Desktop option. Or Rack Mount Kit for Rackmount option.

The following item may be included if long range extension is needed:

- ❖ Long range extension kit
- ❖ A power adapter for CPU/Basic Module, 90-240V AC auto-select
- ❖ A DB25 to DB25 cable which contains only 10 signal pins for connecting Control Board and CPU/Basic Module

Installation Guide

This section gives a brief summary of how to install the Intellio C320Turbo/PCI under each supported operating system. Installation is simple and involves the following stages:

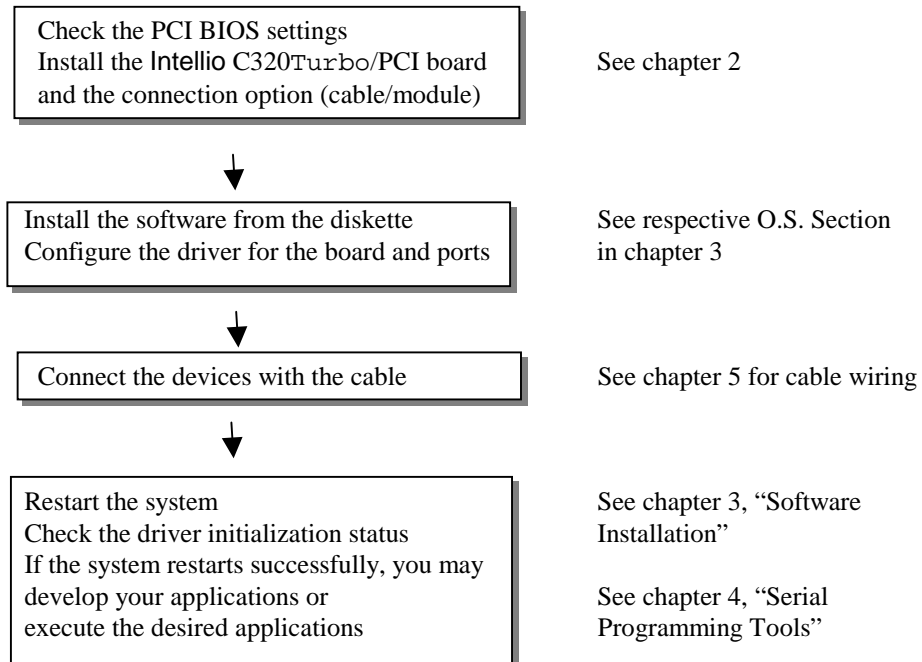

2

Hardware Installation

The installation of **Intellio C320Turbo/PCI** consists of hardware installation and software installation. For software installation, please refer to the respective section of operating systems in the next chapter. Hardware installation is stated in this chapter. The no-switch-no-jumper Intellio C320Turbo/PCI board's hardware configuration for IRQ and memory addresses is automatically assigned by **PCI BIOS**. Hence, **it is a must to have the board plugged first before installing software driver**. After this, simply install the Control Board into the PC and then connect one of the connection options, **Desktop** or **Rackmount**.

The Intellio C320Turbo/PCI hardware installation consists of Control Board installation and external module installation. **Make sure you have connected the Control Board with proper number of external modules .**

Installing the Intellio C320Turbo/PCI Control Board

Step 1: Power off the PC.

Warning !

Make sure you switch off the system before installing any PCI board.If you don't, you may risk damaging your system and the board.

Step 2: Remove the PC's cover.

Step 3: Remove the slot cover bracket if present.

Step 4: Plug the Intellio C320Turbo/PCI firmly into any free 32-bit PCI slot.

Step 5: Fasten the holding screw to make the Control Board fixed.

Step 6: Replace the system cover.

Note! Each board must occupy one unique IRQ and one unique memory address, which are assigned by PCI BIOS automatically. However, you may select the free IRQ number manually via PC's BIOS setup for PCI slot, but this method is not available for memory. The possible IRQ numbers are 2(or 9), 3, 4, 5, 7, 10, 11, 12, and 15.

 Now the installation of the Control Board is complete. Continue to install the external modules.

Installing the External Modules

There are two major connection options for the installation of external modules: CPU and UART Modules for Desktop option or Basic and Extensive Modules for Rackmount option.

Normally, a standard 2-meter DB25 to DB25 cable with 25 signal pins links the Control Board to the external module. However, to extend the distance between Control Board and external module to above **2 m** and up to **100 m (328 ft)** or to improve power insufficiency problem of the PC host, **external power for the CPU/Basic Modules along with a cable specially fabricated with only 10 signal pins** should be used as illustrated in the next two subsections and in chapter 5 as well. Otherwise, power degradation which comes from longer cable or power insufficiency of PC host will cause system failure.

Installing the CPU and UART Modules (Desktop)

Step 7: Connect the Intellio C320Turbo/PCI Control Board to the CPU Module with the shipped DB25 to DB25 cable as shown in the following picture.

If range extension or external power is required, please use 10-signal-pin cable coming with long range extension kit, instead. Thus, there are two types of installation: **without power adapter** and **with power adapter**, which are described as follows:

Without power adapter (for normal condition)

In most cases, you need not a power adapter.

- A: Set the CPU Module power switch to the **OFF** position. This is absolutely necessary when installing or removing the cable, the CPU Module or the UART Module(s). Power should not be switched on until you installed all components.
- B: Plug the DB25 male end of the shipped 2-meter 25-signal-pin cable into the connector on the rear panel of the Intellio C320Turbo/PCI Control Board. Refer to the chapter 5 for the cable pinout details.

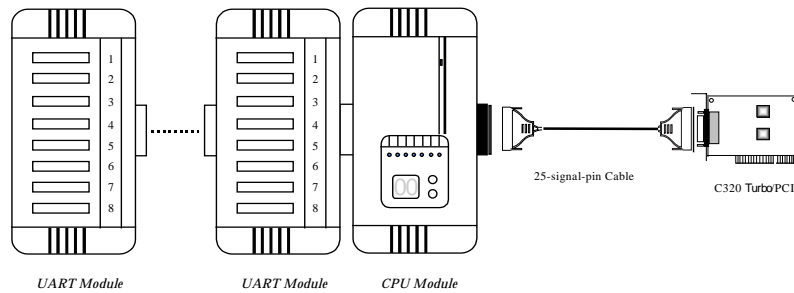

- C: Plug the other DB25 female end into the CPU Module's DB25 connector.

With power adapter (for range extension/external power condition)

In case of range extension or external power requirement, you need a power adapter.

- A: Set the CPU Module power switch to the **OFF** position. This is absolutely necessary when installing or removing the cable, the CPU Module or the UART Module(s). Power should not be switched on until you installed all components.

-
- B: Plug the DB25 male end of the shipped 2-meter 10-signal-pin cable (the **link cable** comes with long range extension kit or the one fabricated according to the pinouts in the chapter 5) into the connector on the rear panel of the Intellio C320Turbo /PCI Control Board.

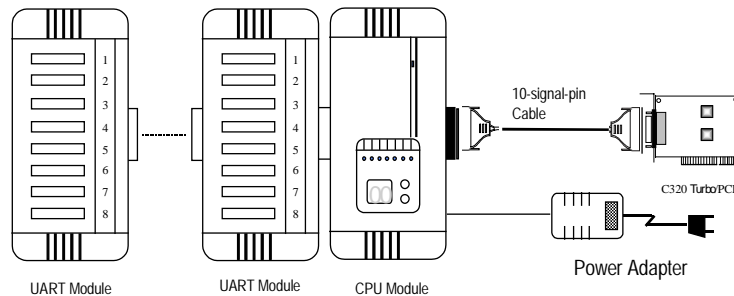

- C: Plug the other DB25 female end into the CPU Module's DB25 connector.

Warning! Do not use a 25-signal-pin cable to connect the Intellio C320Turbo /PCI Control Board to the CPU Module when using the power adapter as this will cause power crash. (One power comes from the power adapter while the other power comes from the Intellio C320Turbo /PCI Control Board.)

- D: Connect the power adapter to the CPU Module. Keep the CPU Module's power switch in the OFF position. If UART Module(s) is (are) also required, keep the CPU Module's power switch in the OFF position until all necessary UART Module(s) is (are) installed.
- E: Install the power adapter to a power source, either 110V or 220V AC. Adjustment to the AC power specs is done automatically.

Step 8: Connect the first UART Module to the CPU Module. Connect the second UART Module to the first one if necessary and so on.

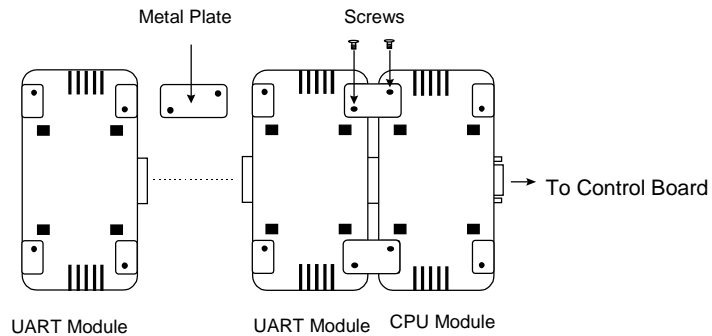

For better fixation of modules, **Fixing Kit** is available and see the bottom view of modules below to install.

Step 9: After making sure that each component has been correctly installed, you are recommended to power on the CPU Module first and then power on the PC system secondly.

 **Now the installation of the external CPU/UART modules is complete. Continue to install the software driver explained in the chapter 3.**

Installing the Basic and Extensive Modules (Rackmount)

Step 7: Connect the Intellio C320Turbo/PCI Control Board to the Basic Module with the shipped DB25 to DB25 cable as shown in the following picture.

If range extension or external power is required, please use 10-signal-pin cable coming with long range extension kit, instead. Thus, there are two types installation: **without power adapter** and **with power adapter**, which are described as follows:

Without power adapter (for normal condition)

In most cases, you need not a power adapter.

Extensive Module

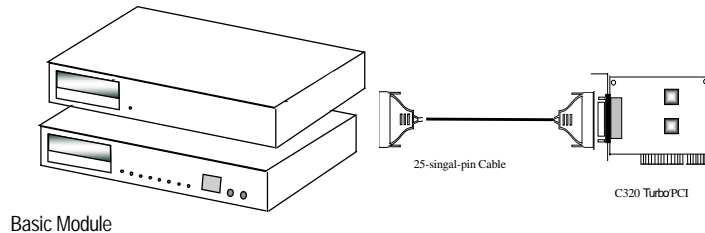

- A: Set the Basic Module power switch to the **OFF** position. This is absolutely necessary when installing or removing the cable, the Basic Module or the Extensive Module(s). Power should not be switched on until you installed all components.
- B: Plug the DB25 male end of the shipped 2-meter 25-signal-pin cable into the connector on the rear panel of the Intellio C320Turbo/PCI Control Board. Refer to the chapter 5 for the cable pinout details.
- C: Plug the other DB25 female end into the Basic Module's DB25 connector.

With power adapter (for range extension/external power condition)

In case of range extension or external power requirement, you need a power adapter.

- A: Set the Basic Module power switch to the **OFF** position. This is absolutely necessary when installing or removing the cable, the Basic Module or the Extensive Module(s). Power should not be switched on until you installed all components.
- B: Plug the DB25 male end of the shipped 2-meter 10-signal-pin cable (the **link cable** comes with long range extension kit or the one fabricated according to the pinouts in chapter 5) into the connector on the rear panel of the Intellio C320Turbo/PCI Control Board.

Hardware Installation

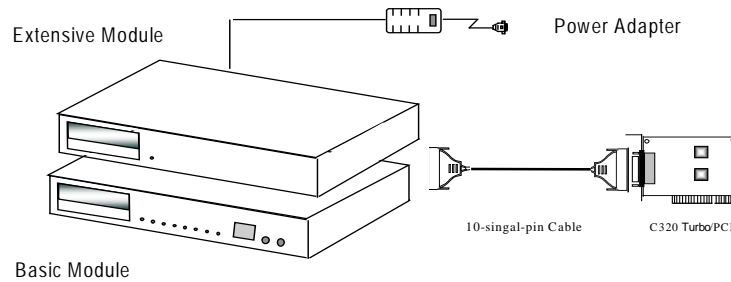

- C: Plug the other DB25 female end into the Basic Module's DB25 connector.

Warning! Do not use a 25-signal-pin cable to connect the Intellio C320Turbo/PCI Control Board to the Basic Module when using the power adapter as this will cause power crash. (One power comes from the power adapter while the other power comes from the Intellio C320Turbo/PCI Control Board)

- D: Connect the power adapter to the Basic Module. Keep the Basic Module's power switch in the OFF position. If Extensive Module(s) is(are) also required, keep the Basic Module's power switch in the OFF position until all necessary Extensive Module(s) is (are) installed.
- E: Install the power adapter to a power source, either 110V or 220V AC. Adjustment to the AC power specs is done automatically.

Step 8: If one more Extensive Module is required, plug the DB37 to DB37 male end of the shipped 1-meter cable into the DB37 female connector on the rear panel of the Basic Module and the other end of the cable into the DB37 male connector on the rear panel of the Extensive Module. If more Extensive Module is needed, connect the next Extensive Module to the previous one as described above.

To mount the module(s) on the industrial standard 19" rack, **Rack Mount Kit**, including two L-type plates and eight screws, should be applied.

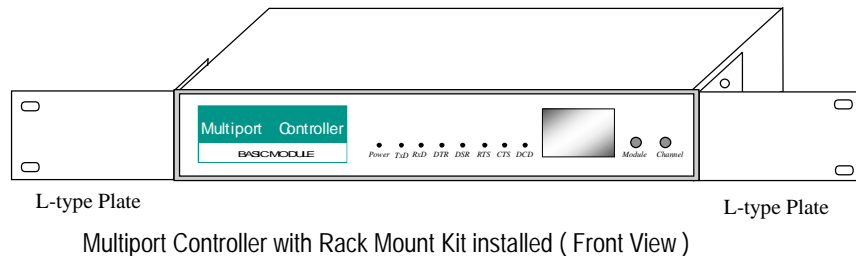

Step 9: After making sure that each component has been correctly installed, you are recommended to power on the Basic Module first and then power on the PC system secondly.

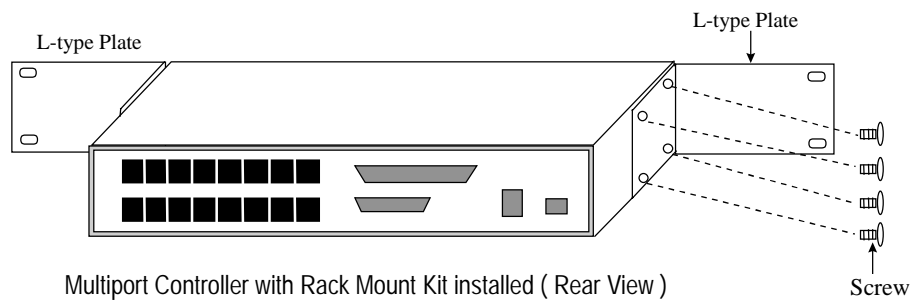

 **Now the installation of the external Basic/Extensive module is complete. Continue to install the software driver explained in chapter 3.**

Operating LED Indicators

After completing the installation and powering on the CPU/Basic Module and the PC system, check the two-digit LED display on the CPU/Basic Module. These LEDs show the results of the system self-diagnostic tests, which are run by the CPU/Basic Module after startup.

The CPU/Basic Module will first test the ROM and RAM of itself, and then UART/Extensive Module(s) if present. If any error is found, the LED display will show one of the messages described in "Troubleshooting" chapter.

If the first test passed, the CPU/Basic Module will then display “**Ld**” waiting for loading firmware from the Intellio C320Turbo/PCI Control Board. After loading the firmware, the CPU Module will scan for the number of UART Modules or the number of ports available. The LED will show the last accessible port.

CPU Module

The left digit shows the UART Module number and the right digit shows the last port number within a UART Module. The UART Module closest to the CPU Module is of number 1. The next module is of number 2, and so on. For example, if “**48**” is displayed, it means that the last accessible port is the eighth port of the fourth UART Module.

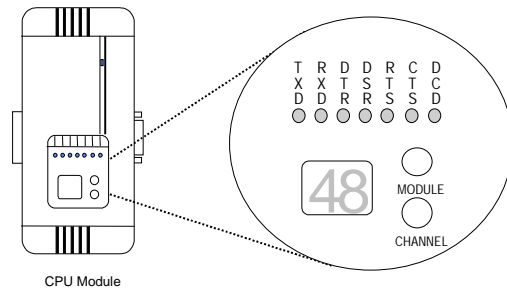

Basic Module

The left digit shows the number of 8-port unit that configured (if continuous 8 ports are considered as an 8-port unit) and the right digit shows the last port number within an 8-port unit. For example, if “**48**” is displayed, it means that the last accessible port is the eighth port of the fourth 8-port unit.

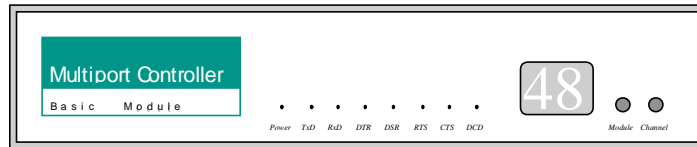

Basic Module

To see a particular port’s line status, you can keep pressing Module Button and Channel (Port) Button till the desired port is shown on LED display, then look at the seven indicators TxD, RxD, DTR, DSR, RTS, CTS, and DCD. This provides a convenient diagnostic ways for Intellio C320Turbo/PCI. Normally, DTR and RTS

indicators will light on when local port is opened while DSR and CTS indicators will light on when remote port is opened. TxD indicator will light on if local port is transmitting data and RxD indicator will light on if local port is receiving data (or remote port is transmitting data). DCD indicator is mostly useful to detect phone line carrier when a modem is connected to the port.

Mix of Various UART Modules

UART Modules with various functions are produced for different requirements, such as RS-232/RS-422, female/male DB25 connector, isolation protection or surge protection.

No matter what interfaces they use, any two UART Modules could be mixed (connected) together freely depending on needs. For example, you may put 2 male RS-232 UART Modules and 2 female RS-422 UART Modules together for application consideration.

3

Software Installation

In this chapter, software driver installation, configuration and driver update/removal procedures are described for various operating systems, including Windows NT, Windows 95/98 and UNIX. Before proceeding with software installation, complete the hardware installation detailed in the previous chapter.

However, if you need to develop applications, refer to the next chapter, “Serial Programming Tools”, for more information.

Windows NT

Windows NT supports up to **256** serial ports, from **COM1** to **COM256**. To fully integrate the advanced features of Windows NT, multi-process and multi-thread, pure 32-bit Windows NT device drivers are developed for Intellio C320Turbo/PCI and other MOXA multiport boards. The drivers conform to Win32 COMM API standard.

If you install the driver for the first time, please go directly to the section “Installing Driver”.

If you already have installed the driver and want to re-configure the board and port, add more boards or delete boards, please refer to the section “Configuring Board and Port”.

If you want to update or even remove driver, please go to the section “Updating Driver” and section “Removing Driver”.

If you want to remove boards, please simply unplug the desired boards from the system.

Installing Driver

Following is the procedure for installing the Intellio C320Turbo/PCI driver **for the first time** under Windows NT 3.51/4.0. Make sure the board(s) has(have) already been plugged in the PCI slot of the PC.

1. Please Login NT as **Administrator**.
2. Open the [**Control Panel**], click on the [**Network**] icon and select the [**Adapters**] tab.
3. Click on the [**Add**] button, then [**Have Disk...**] button in “Select Network Adapter”.
4. Specify the exact path of the driver diskette, **A:\WINDOWS.NT**. Click [**OK**].

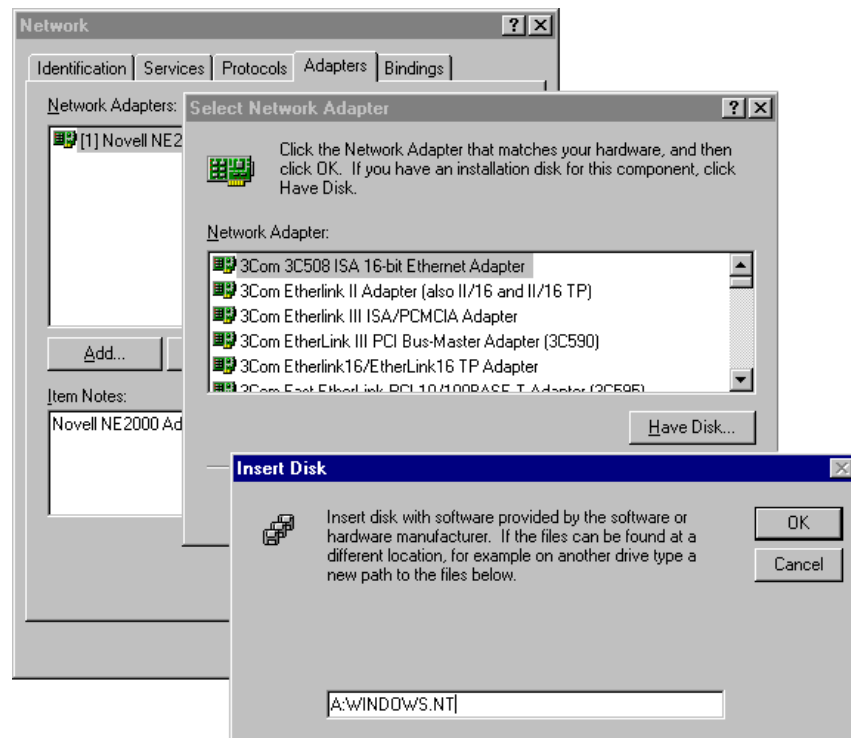

5. Select “**MOXA Intellio Family Multiport Board**” in the “Select OEM Option” dialog box, and click [OK] to enter the “**MOXA Configuration Panel**” dialog box to start the installation.

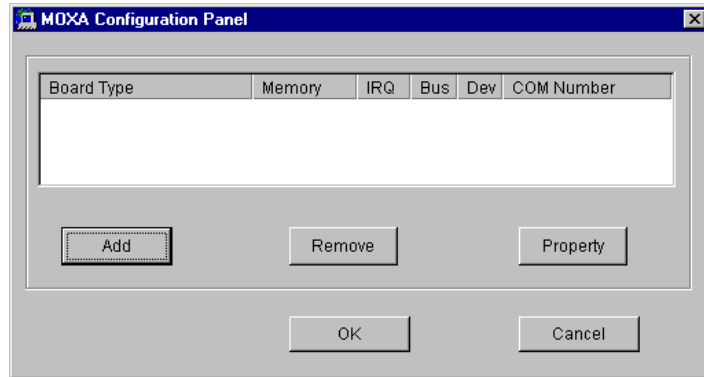

6. In the “**MOXA Configuration Panel**” dialog box, click [Add] to enter “**Property**” dialog box to add the Intellio C320Turbo/PCI board. Select the “**C320Turbo/PCI**” in the “Board Type” field and choose the appropriate one, **8**, **16**, **24**, or **32** ports, in the “Total Ports” field, which should match the number of ports that are physically connected.

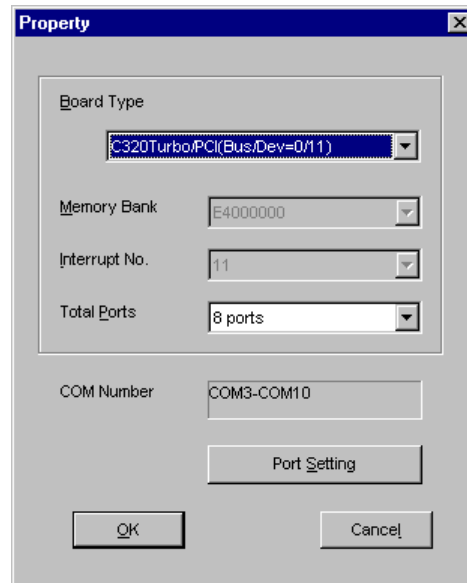

-
7. In the “**Property**” dialog box, click [**Port Setting**] to enter the “**Individual Port Setting**” dialog box to change the port COM number mappings.

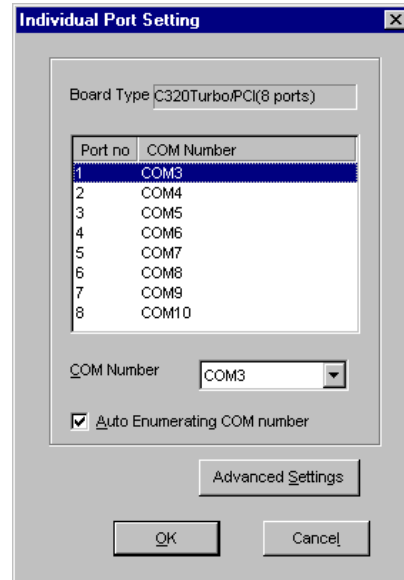

You have to set up all the ports of the board with the desired “**COM number**”, which should not conflict with other COM number in use. In this “Individual Port Setting” dialog box, you may have two ways to map the physical ports to COM numbers depending on the check box “**Auto Enumerating COM number**”.

- **Sequential Port Mapping:** (Enable “Auto Enumerating COM number”) Specify the COM number of the first port and subsequent ports are mapped to continuous COM numbers. For instance, if first port is mapped to COM10, then second port is mapped to COM11 sequentially.
- **Non-sequential Port Mapping:** (Disable “Auto Enumerating COM number”) Specify the COM number for individual port. For instance, the second port can be out of sequence, say COM18, while the first port is mapped to COM10.

In “Individual Port Setting” dialog, you may click on [**Advanced Setting**] button to tune the advanced features, “**UART FIFO**” and “**Transmission Mode**”, for each port for particular performance requirements.

Note! You may skip the following settings and go directly to the next **step 8** if you do not require any particular performance tuning for the

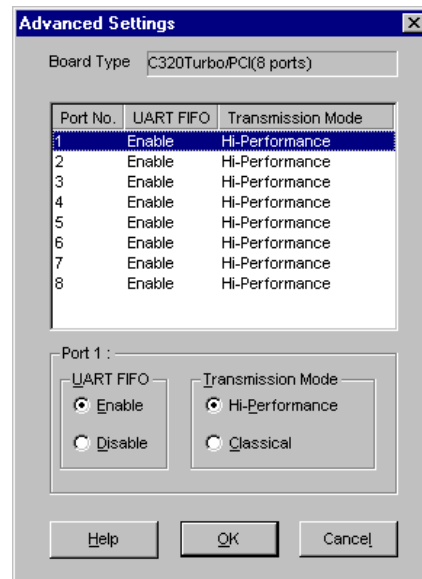

In the “Advanced Settings” dialog, you may customize the driver with the following two features:

- **UART FIFO**
Enable: You can set this feature to “Enable” (default) and gain best performance for the board.
Disable: You can set this feature to “Disable” to avoid from data loss when communicating with communication devices using S/W flow control.
- **Transmission Mode**
Hi-Performance Mode: This feature is set to “Hi-Performance” by default, which accelerates the reaction of data writing behavior by utilizing buffering technology. It lets your communication software reach maximum data throughput in large data transmission.

Classical Mode: It lets MOXA ports behave like generic COM ports. Transmission for small data packets would be more precisely and reliable.

8. Click **[OK]** in the “Individual Port Setting” and the “Property” dialog boxes to go back to the “MOXA Configuration Panel” dialog box. Click **[OK]** to finish the configuration.

However, if you installed more than one board, click **[Add]** and repeat steps **6** and **7** to configure another board. Up to four Intellio C320Turbo/PCI boards can be installed in a system.

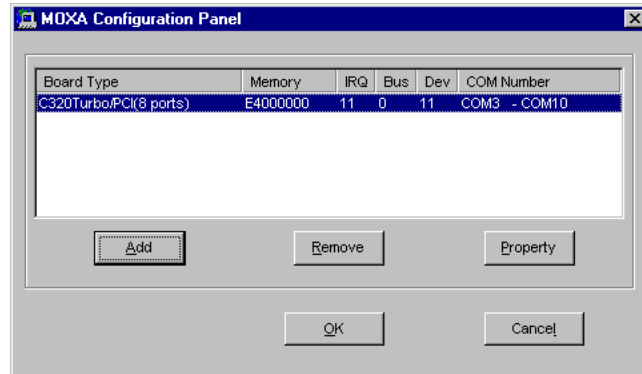

9. When the configuration is done, click **[OK]** in the “Network” dialog box.
10. **Restart Windows NT system.** The latest configuration will not take effect unless the system restarts.

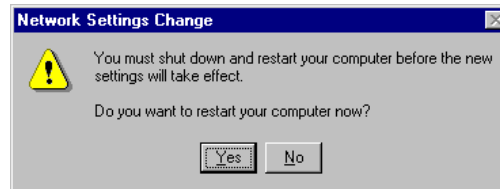

Note ! Please **double check** if all the Intellio C320Turbo/PCI components: Control Board, link cable and external cable/module, are connected and fastened tightly to make sure that the system and the driver start successfully later.

11. Once the system restarts, you may check the event log issued by MOXA drive to see if the ports of the board are initialized successfully.

Enter the [Administrative] group, [Event Viewer] and select [Application Event Log] to check a successful message similar to “MOXA C320Turbo/PCI Multiport Board #1: addr(XXX) O.K.” for each configured board.

- If an error message similar to “MOXA C320Turbo/PCI Multiport Board #1 addr(XXX): IRQ(10) test failure!” appears, refer to the “Troubleshooting” chapter for solutions.

Note ! Once the board and driver are installed and the system restarts successfully, you can start to develop applications by using **PComm** library (See “Serial Programming Tools” chapter) or using Microsoft Win32 API. you can also execute any ready-made application, such as **PComm** utility Terminal emulator (See “Serial Programming Tools” chapter) or HyperTerminal to transmit/receive data, as well as Remote Access Service to provide dial-up networking capability.

Configuring Board and Port

If you already have installed the driver and want to re-configure the board and port, add more boards or delete boards, please follow this procedure.

1. Open [Control Panel], click [Network] and select the [Adapters] tab.
2. Select “MOXA Intellio Family Adapter” in the “Installed Adapter Cards:”.

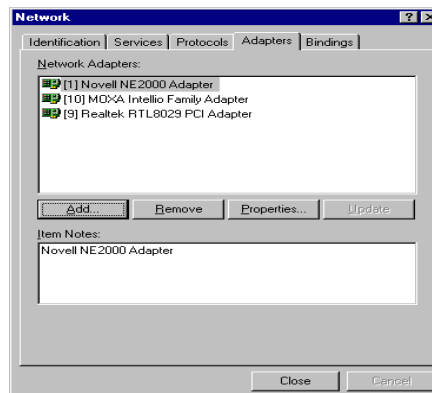

-
3. Click on the [**Properties...**] button to enter the “MOXA Configuration Panel” dialog box.

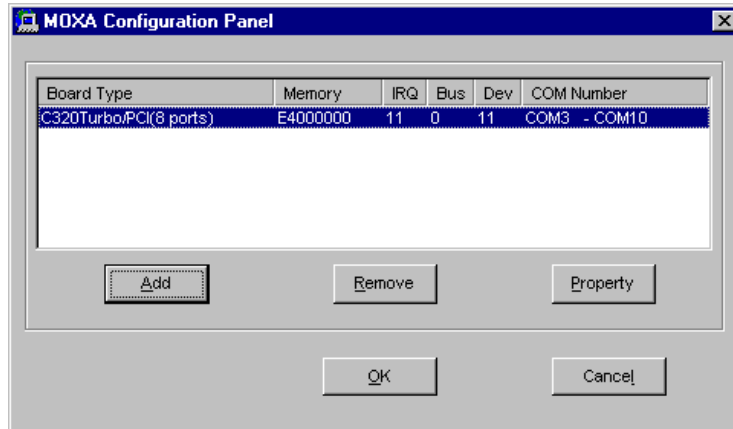

In this configuration panel, you may:

- Click [**Property**] to enter “Property” dialog box to configure the selected board with the correct “**Total Ports**” and “**COM Number**”. Please see **steps 6 to 8** in the previous section, “Installing Driver”, for more details, except that the “Board Type” field is not supposed to be changed.
- Click [**Add**] to add one more board that is not yet configured in the system. Up to four of **Intellio C320Turbo/PCI** boards can be installed together as long as the memory and IRQ resources are sufficient and available in a system. Please see **steps 6 to 8** in the previous section, “Installing Driver”, for more details.
- Click [**Remove**] to remove the board currently selected from the configured board list.
- Click [**OK**] to confirm the configuration changes you made.
- Click [**Cancel**] to leave the dialog with the configuration unchanged.

Adding/Removing Board

Following is the procedure to add/remove Intellio C320Turbo/PCI Series boards after a first time installation. Note that **the presence of the board(s) is(are) required for adding boards.**

1. Power off the system.
2. Plug/unplug the boards in the system.
3. Power on the system.
4. Run the software configuration “MOXA Configuration Panel” to add/remove the boards, detailed in the previous “Configuring the Board and Port” section.

Updating Driver

To update the driver for the Intellio C320Turbo/PCI board, simply remove the driver, as described in the next section, and then reinstall it as detailed in the “Installing Driver” section.

Removing Driver

To remove the driver for the Intellio C320Turbo/PCI board,

1. Open the [Control Panel], click on the [Network] icon and select the [Adapters] tab.
2. Select “MOXA Intellio Family Adapter” in the adapter list, then click on the [Remove] button and the [OK] button to remove the driver.
3. Restart the system to activate the new configuration.

Windows 95/98

Windows 95/98 supports up to **128** serial ports, from **COM1** to **COM128**. To fully integrate the advanced features of Windows 95/98, multi-process and multi-thread, pure 32-bit Windows 95/98 virtual device port drivers (VxD) compliant with communication driver (VCOMM) are developed for Intellio C320Turbo/PCI and other MOXA multiport boards. The drivers conform to Win32 COMM API standard.

If you install the driver for the first time or you want to install more boards, please go directly to the section “Installing Driver”.

If you already have installed the driver and want to re-configure the board, please refer to the section “Configuring Board and Port”.

If you want to update or even remove driver, please go to the section “Updating Driver” and section “Removing Driver”.

If you want to remove boards, please simply unplug the undesired boards from the system.

Installing Driver

If you install for the first time, or you want to install more boards, this section is for you.

You can easily plug the Intellio C320Turbo/PCI board and work right away with very little installation efforts under Windows 95/98, which supports **Plug and Play** capability. The Windows 95/98 will automatically detect the presence of the newly plugged board and prompt you to install the software driver the first time. In this case, you need the driver diskette.

Up to four Intellio C320Turbo/PCI boards can be installed together as long as the memory addresses and IRQ number resources are sufficient and available in a system.

The following flow chart illustrates the driver installation stages of the Intellio C320Turbo/PCI board. Each stage is detailed later.

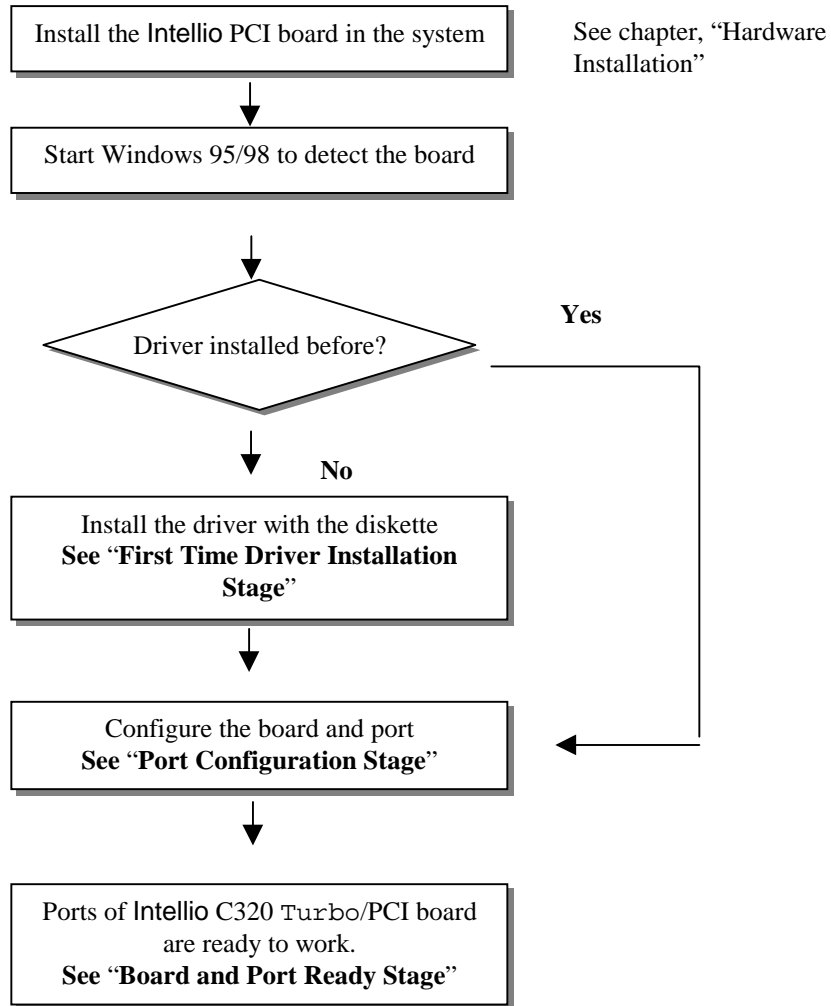

First Time Driver Installation Stage

The stage presents the steps for installing the driver for the first time with the first Intellio C320Turbo/PCI board. The installation of Intellio C320Turbo/PCI board for Windows 95 and Windows 98 **differs slightly** and will be described in two columns. **Follow the steps in the left or right column for Windows 95 or 98, respectively.**

1. Upon detecting **the first new Intellio C320Turbo/PCI board**, Windows 95/98 will automatically show a "New hardware found" message box and then display the following dialog box. Click on the [Next>] button.

Windows 95

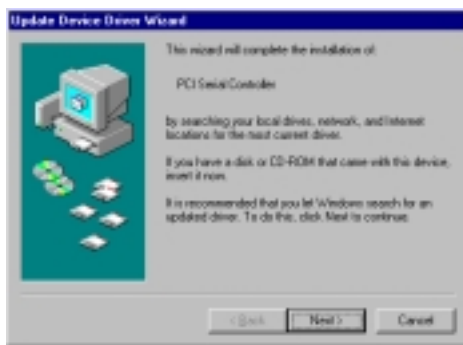

Windows 98



2. Click on the [Other Location] button.



2. Select "Display a list ..." and click [Next>].



Software Installation

3. Type “A:\Windows.95” in the Location field, and click [OK]. The system will start reading the files from the diskette.



3. Select “Other Devices” and click [Next>].



4. Click on the [Finish] button.



4. Click on the [Have Disk] button.

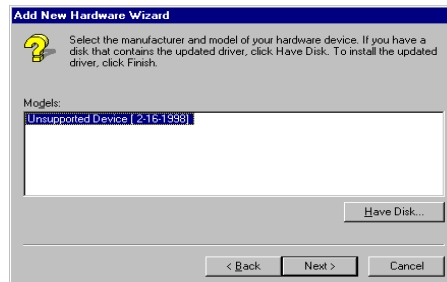

5. Type “A:\Windows.95” and click [OK]. The system will start reading the files from the diskette.

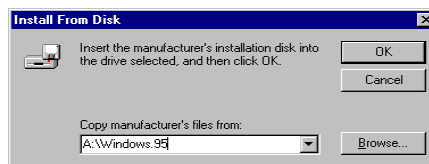

6. Click [Next>].

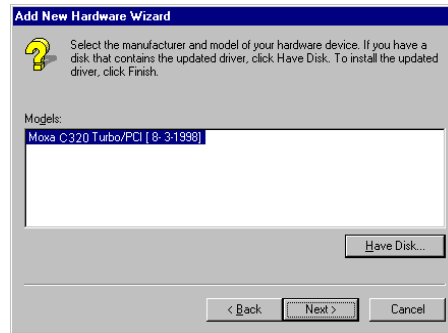

7. Click [Next>].



Port Configuration Stage

This stage displays the “C320Turbo/PCI Installation” dialog box for the port configuration. Here you can map the MOXA ports to the system COM numbers.

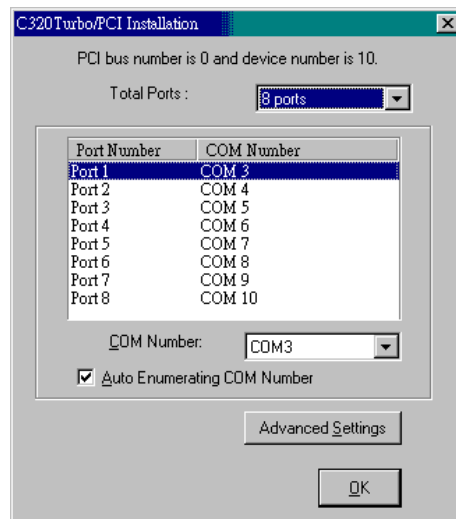

In the “C320Turbo/PCI Installation” dialog box, you can map the physical ports to COM numbers in two ways depending on the “Auto Enumerating COM number” check box.

- **Sequential Port Mapping:** (Enable “Auto Enumerating COM number”) Specify the COM number of the first port and subsequent ports are mapped to continuous COM numbers. For instance, if first port is mapped to COM10, then second port is mapped to COM11 sequentially.
- **Non-sequential Port Mapping:** (Disable “Auto Enumerating COM number”) Specify the COM number for individual port. For instance, the second port can be out of sequence, say COM18, while the first port is mapped to COM10.

In addition, in the “C320Turbo/PCI Installation” dialog box, you may click on [Advanced Settings] button to tune the advanced features, “UART FIFO” and “Transmission Mode”, for each port for particular performance requirements.

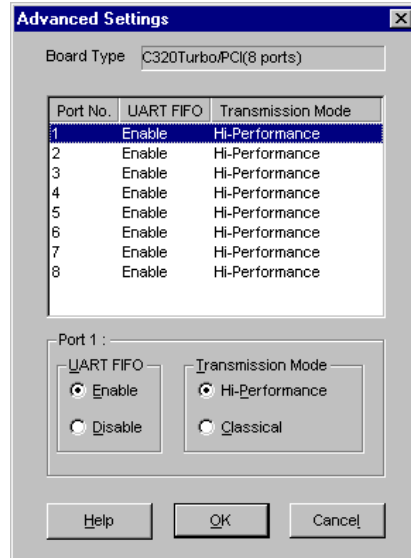

In the “Advanced Settings” dialog box, you may customize the driver with the following two features:

- **UART FIFO**
Enable: You can set this feature to “Enable” (default) and gain best performance for the board.
Disable: You can set this feature to "Disable" to avoid from data loss when communicating with communication devices using S/W flow control.
- **Transmission Mode**
Hi-PerformanceMode: This feature is set to “Hi-Performance” by default, which accelerates the reaction of data writing behavior by utilizing buffering technology. It lets your communication software reach maximum data throughput in large data transmission.
Classical Mode: It lets MOXA ports behave like generic COM ports. Transmission for small data packets would be more precisely and reliable.

Board and Port Ready Stage

Click [**OK**] for all the dialog boxes to finish the configuration and exit the “MOXA Ports Installation” dialog box.

In this last stage, you will complete the driver installation.

Windows 95

After the port installation, you can **immediately** use the COM ports of the Intellio C320Turbo/PCI board **without restarting the Windows 95 system.**

Windows 98

After the port installation, click on the [**Finish**] button. Now you can **immediately** use those COM ports of the Intellio C320Turbo/PCI board **without restarting the Windows 98 system.**





Once the installation is finished, error conditions of the board, **if any**, are displayed on the screen. Otherwise, everything should be fine.

If an error message similar to “C320Turbo/PCI (BusNo=x, DevNo=x) at base memory [XXX] interrupt failure!” appears, consult the “Troubleshooting” chapter.

Note ! Up to now, the driver installation of Intellio C320Turbo/PCI is complete and successful, including the board and port configuration. However, if changes of the board and port configuration are needed, please refer to the next section, “Configuring Board and Port”, for more configuration details.

Note ! Once the board and driver are installed and the driver restarts successfully, you can start to develop applications with the **PComm** library (See “Serial Programming Tools” chapter) or the Microsoft Win32 API. You can also execute any ready-made application, such

PCComm utility Terminal emulator (See “Serial Programming Tools”) or HyperTerminal to transmit/receive data, as well as Remote Access Service to provide dial-up networking capability.

-  If multiple boards are installed at the same time, the same scenario applies for the next boards, except that no driver diskette is asked any more.
-  Similarly, if you want to add more boards and the driver has been installed before, simply plug the **Intellio C320Turbo/PCI** board and Windows 95/98 will automatically detect and install the required driver.

Configuring Board and Port

If you already have installed the driver and want to re-configure the Intellio C320Turbo/PCI board under Windows 95/98, the following is the procedure for you.

1. Click on the Taskbar [Start] button, select the [Programs] menu, and the [MOXA Utilities] menu and the [MOXA Configuration Panel] icon.

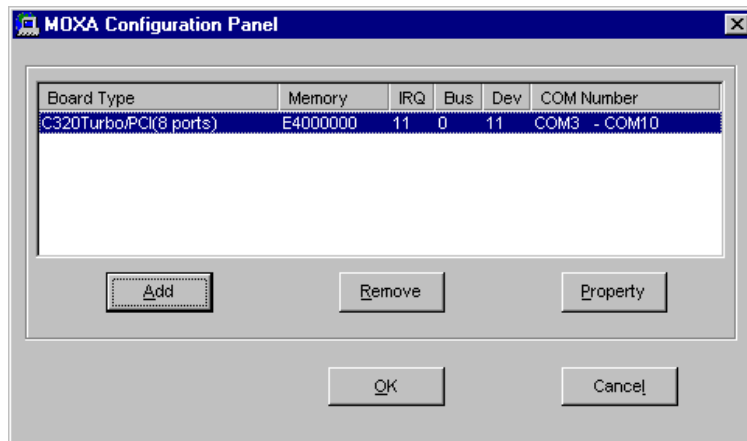

The [Add] button and the [Remove] button are not applicable in PCI case. A new C320Turbo/PCI board will be automatically found as new hardware and added during the Windows 95/98 startup. To remove a board, simply unplug the undesired C320Turbo/PCI board physically from the system.

2. Click [Property] to enter "Property" dialog box to re-configure the selected board with the desired "Total Ports" and "COM Number". Choose the appropriate one, **8**, **16**, **24**, or **32** ports, in the "Total Ports" field, which should match the number of ports that will be physically connected.

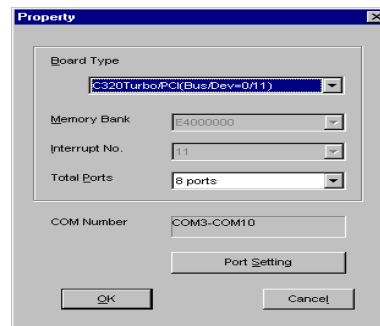

-
3. In the “Property” dialog, you may click on the [**Port Setting**] button to enter the “Individual Port Setting” dialog box to change the port COM number mappings.

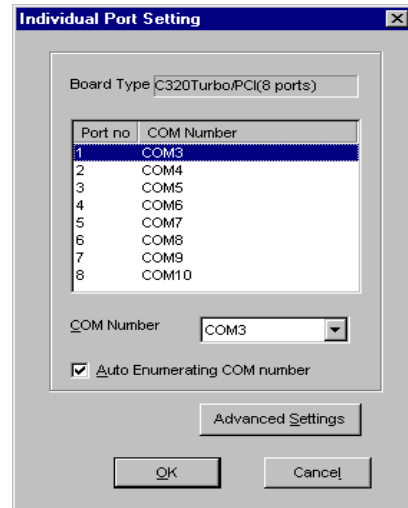

In the “Individual Port Setting” dialog box, you may have two ways to map the physical ports to COM numbers depending on the “**Auto Enumerating COM number**” check box.

- **Sequential Port Mapping:** (Enable “Auto Enumerating COM number”) Specify the COM number of the first port and subsequent ports are mapped to continuous COM numbers. For instance, if first port is mapped to COM10, then second port is mapped to COM11 sequentially.
- **Non-sequential Port Mapping:** (Disable “Auto Enumerating COM number”) Specify the COM number for individual port. For instance, the second port can be out of sequence, say COM18, while the first port is mapped to COM10.

In the “Individual Port Setting” dialog box, you may click on [**Advanced Settings**] button to tune the advanced features, “**UART FIFO**” and “**Transmission Mode**”, for each port for particular performance requirements.

Note! You may skip the following settings and go directly to the next **step 4**, if you do not require any particular performance tuning for the driver.

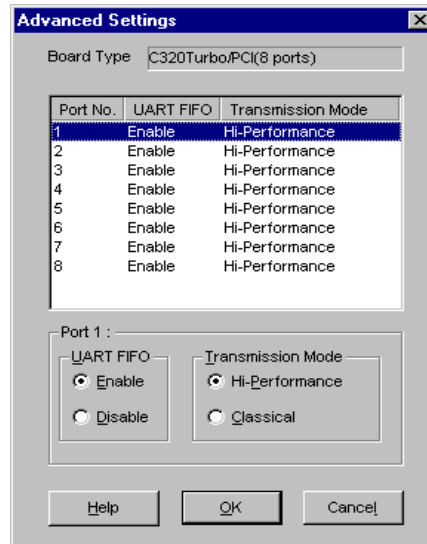

In the “Advanced Settings” dialog box, you may customize the driver with the following two features:

- **UART FIFO**

Enable: You can set this feature to “Enable” (default) and gain best performance for the board.

Disable: You can set this feature to "Disable" to avoid from data loss when communicating with communication devices using S/W flow control.

- **Transmission Mode**

Hi-PerformanceMode: This feature is set to “Hi-Performance” by default, which accelerates the reaction of data writing behavior by utilizing buffering technology. It lets your communication software reach maximum data throughput in large data transmission.

Classical Mode: It lets MOXA ports behave like generic COM ports. Transmission for small data packets would be more precisely and reliable.

-
4. Click **[OK]** in the “Individual Port Setting” and the “Property” dialog boxes to go back to the “MOXA Configuration Panel” dialog box. Click **[OK]** to finish the configuration.
 5. **Restart Windows 95/98 system if you have changed any setting.** The latest configuration will not take effect unless the system restarts.

Updating driver

Open the [Control Panel] and click on the [System] button, and select the [Device Manager] tab. Select the “Moxa Intellio Multiport Board” entry and the “Moxa C320Turbo/PCI” entry. Click on the [Property] button and select the [Device Driver] tab and then click on the [Update Driver...] button.

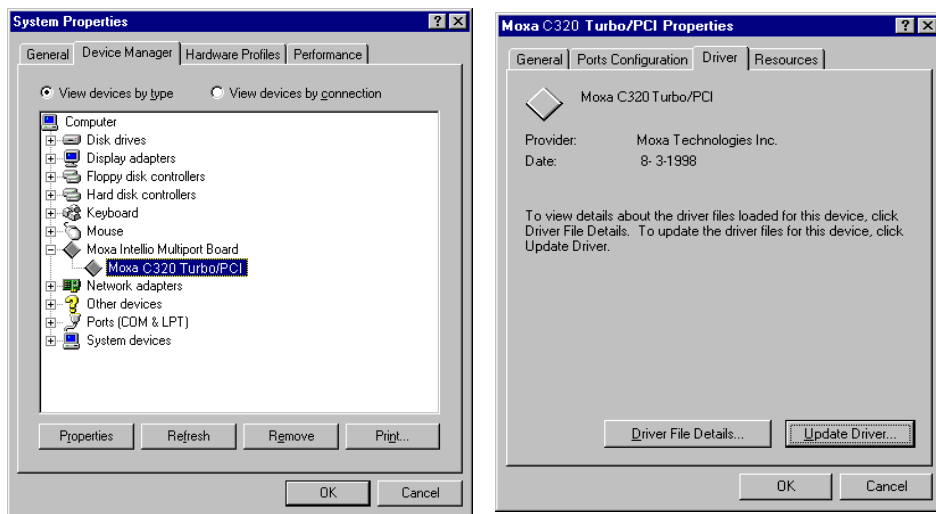

Removing driver

Open [Control Panel] icon, and then [Add/Remove Programs] icon, and then select [Install/Uninstall] tab. Then select and open the “MOXA Intellio Driver” option and then enter [OK] to remove the driver.

UNIX

Installing Driver

Up to four boards of combination of Intellio C320Turbo/PCI and C320Turbo can be installed together as long as memory resources are sufficient and available in a system.

Step 1. Boot the system and login from the console as a super user (root).

Step 2. Insert the driver diskette into a 1.44MB floppy drive, A: or B:.

If the driver files are obtained from the MOXA **FTP** service, put them under the **/tmp/moxa** directory and **skip to the step 5.**

Step 3. Change to the root directory by entering the following command:
`# cd /`

Step 4. Enter the following command to extract the installation script file first.
`# tar xvf /dev/fd0135ds18 /tmp/moxa/mxinstall` (if 1.44MB A:)

Step 5. `# /tmp/moxa/mxinstall`

Follow the instructions prompted to finish the driver installation

Copyright (C) 199x Moxa Technologies Co., Ltd. All Rights Reserved.

MOXA UNIX Device Driver Installation Ver. x.x

Please select one of the following OS:

1. SCO UNIX
2. UNIX SVR4.2
3. XENIX

Select:

Please type 1 for SCO UNIX 3.2.x, SCO OpenServer or SCO Open Desktop. Type 2 for UNIX SVR4.2, UnixWare or MITUX. Type 3 for XENIX.

Please select one of the devices where the driver diskette/files put:

- | | |
|--------------------|-------------|
| 1. /dev/fd0135ds18 | (A: 1.44MB) |
| 2. /dev/fd096ds15 | (A: 1.2 MB) |
| 3. /dev/fd1135ds18 | (B: 1.44MB) |
| 4. /dev/fd196ds15 | (B: 1.2 MB) |
| 5. Hard Disk | /tmp/moxa |

Select:

Please type 1, 2, 3, 4 or 5.

Step 6. The **MOXA Multiport Board Installation Utility** dialog will show for driver installation. When finished, press any key to continue.

SCO UNIX or SCO OpenServer or XENIX

You will be prompted to rebuild kernel at this moment and you are recommended to do so unless you need to install other driver. Please type “y”. After kernel rebuild, please shutdown the system on your own.

UNIX SVR4.2 or UnixWare or MITUX

You will be prompted to shutdown the system on your own for kernel rebuilding and you are recommended to do so.

Step 7. Once the system reboots, run “**mxadm**” to configure the board and port.

Select and open “**Basic Configuration**” to do the basic board and port configuration. You may further optionally select and open “**Advanced Configuration**” to do the advanced settings.

Select and open “**Board Reset**” to reset the driver and board for the latest configuration to take effect.

For more details, see later section, “**Administration Utility - mxadm**”.



Up to now, you have already completed the whole installation and the Intellio C320Turbo/PCI board is ready to work.

Note! Please **double check** if all the Intellio C320Turbo/PCI components: Control Board, link cable and external modules are connected and fastened tightly to make sure that the system and the driver starts successfully.

 **Now you can run any ready-made applications such as `getty terminal` or `PPP/SLIP`. You can also start to develop applications with Standard UNIX system calls, as well as MOXA extended UNIX `Ioctl()` Commands. (See “Serial Programming Tools” chapter)**

MOXA TTY Device Naming Convention

If the Intellio C320Turbo/PCI is successfully configured, there will be two tty devices created for each port at `/dev` directory: one is **non-MODEM tty** (e.g. `ttya11`), and the other is **MODEM tty** (e.g. `ttyA11`). The two devices are actually accessing the same physical port except that the MODEM tty has to check the ON status of DCD signal to be able to open device, and closing device automatically as DCD signal is OFF.

The convention of the MOXA tty device name is `/dev/tty{a-d}{1-4}{1-8}`, where (if continuous 8 ports are viewed as an 8-port unit for Intellio C320Turbo/PCI Rackmount):

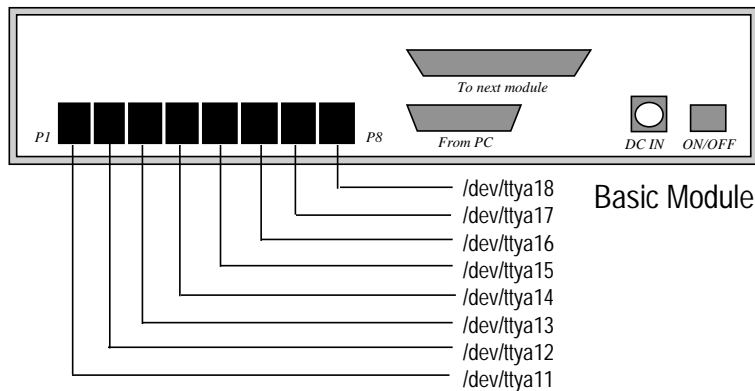
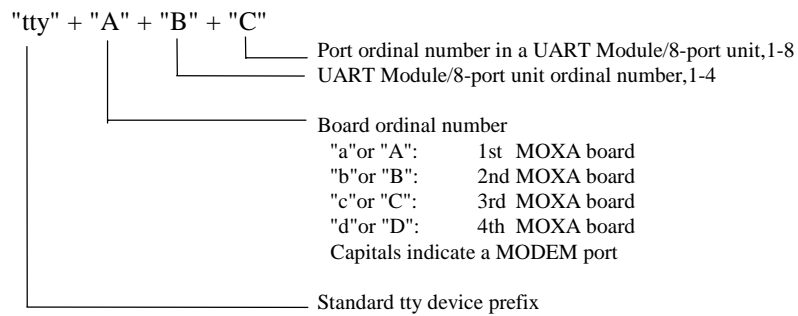

Taking 8 port Intellio C320Turbo/PCI as an example,

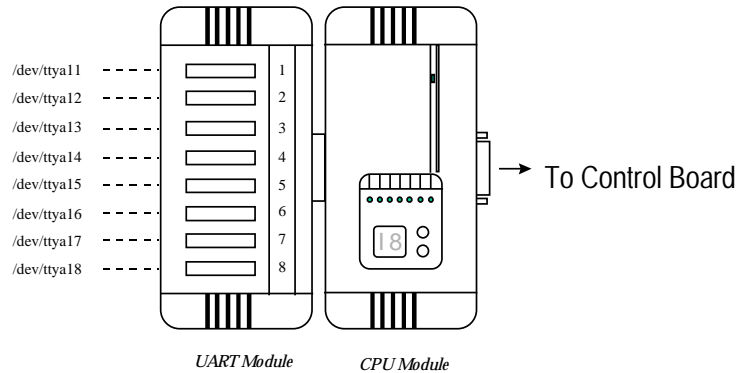

Administration Utility - mxadm

You can use the administration utility, **mxadm**, to change the Intellio C320Turbo/PCI **basic and advanced configuration**, to **reset the board**, to **tune performance** and to **remove the installed MOXA driver** from the UNIX system, which are detailed as follows. For the details of the rest utilities: **port monitoring**, **and terminal emulator**, please refer to “UNIX” section of “Serial Programming Tools” chapter.



Basic Configuration

This utility is to configure basic settings for the driver.

1. In the “Basic Configuration” dialog box, you should first press Enter in the

Software Installation

“**Board type**” field to select board type, **C320Turbo/PCI**. And a list of Intellio C320Turbo/PCI boards found available is for you to select. Normally, one choice is available if there is one Intellio C320Turbo/PCI board installed beforehand.

MOXA Multiport Board Administration Utility				
MOXA Board Basic Configuration				
Board No.	Board Type	Ports	Memory Bank	Bus/Dev No.
1	C320 Turbo/PCI	16	E4000000	0/9
2	NONE	--	-----	-----
3	NONE	--	-----	-----
4	NONE	--	-----	-----
PgDn: getty Setting Esc:Exit				

Secondly, select number of ports in the “**Ports**” field to match exactly the number of ports physically connected.

Press Enter on the desired entry of the list to select. Now the selected Intellio C320Turbo/PCI board is configured with BIOS assigned memory address and Bus/Device numbers as shown.

- Press Page Down to enter “**getty Setting**” sub-dialog, there are some noticeable fields for initialize the port for getty usage. You may skip this step if you will not use getty utility.

MOXA Multiport Board Administration Utility					
getty Setting					
Board	Board No.	Device Name	non-MODEM	MODEM	ev No.
1	1	ttga11/A11			
	1	ttga12/A12	m	k	10
	1	ttga13/A13	m	k	
2	1	ttga14/A14	m	k	
	1	ttga15/A15	m	k	
3	1	ttga16/A16	m	k	
	1	ttga17/A17	m	k	
4	1	ttga18/A18	m	k	
	1	ttga18/A18	m	k	
PgUp,PgDn:More Ports Enter:Select Esc:Exit					

Non-Modem and Modem Baud Rate

This field stands for the initial baud rate symbol and hunt sequence for Non-Modem /Modem tty. It is simply for setting parameters of getty entries in system

file `/etc/inittab` which could also be manually modified by system administrator.

Its value comes from the UNIX system “getty default” file, i.e., “`/etc/gettydefs`”. Modify this field to suit your need.

In some cases, you may need to modify the “getty default” file as well. For example, in some UNIXs, the “9600” symbol indicated 8-data-bit no-parity while in others it may stand for 7-data-bit, even-parity. So, please examine the “getty default” file carefully, and make sure the terminal settings is the same. Otherwise, garbled data will be inevitable.

Advanced Configuration

This utility is to configure advanced settings for the driver, excluding basic settings described in the previous **Basic Configuration**. Similarly, in the “Board Settings” dialog box, **board reset** (described later) is available for the latest configuration to take effect without kernel rebuilding and system reboot.

1. In the “Advanced Board Configuration” dialog box, you can press Enter in each field to select the desired option. The fields are detailed as follows.

MORA Multiport Board Administration Utility			
MORA Board Advanced Configuration			
Board No.	Board Type	OnBoard LineDiscipline	Baudrate Mapping
1	C320 Turbo/PCI	Enable	High Band
2	NONE	-----	-----
3	NONE	-----	-----
4	NONE	-----	-----

F1:Help PgDn:Port Feature Settings Esc:Exit

On Board Line Discipline

Advanced feature is set to “**Enable**” by default, which means all the tty line discipline jobs, e.g. translating NL to CR, will be done on the Intellio C320Turbo/PCI board (Terminal mode), instead of doing them on host. This will significantly reduce the host workload. If it is set to “**Disable**”, the tty line discipline will either be done on host (Terminal mode) or be not done at all (Transparent mode). Please refer to “Feature” field in the “Advanced Port Settings” dialog box on next page.

Baud Rate Mapping

This advanced feature is set to “**High Band**” by default, indicating that the baud rate 50, **B50**, will no longer stand for 50 bps. Instead, B50 means 57600 bps, **B75** is for 115.2 Kbps, **B110** is for 230.4 Kbps, and **B134** is for 460.8 Kbps. You may press F1 Help for on-line details.

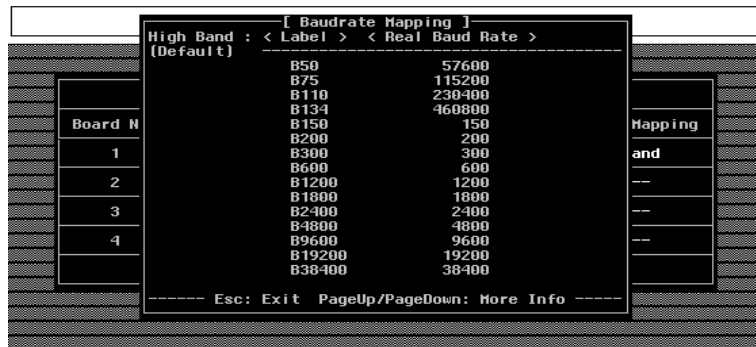

2. Press PageDown to enter the “Advanced Port Settings” sub-dialog, there are some noticeable fields to initialize the ports for advanced usage. You may skip this step if you do not concern these features.

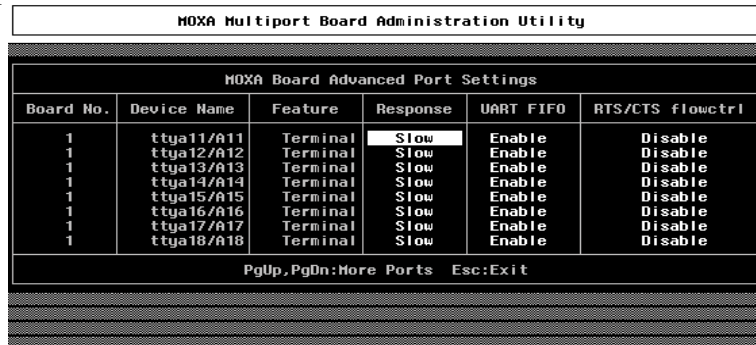

Feature

In the “Port Feature Settings” sub-dialog, port feature [Terminal] is the only choice if On Board Line Discipline is set to “Enable”. This is good for terminal application.

However, if On-Board Line Discipline is set to “Disable”, port feature could be either [Transparent] or [Terminal]. In case of [Terminal], all the tty line discipline jobs will be done on host which surely is a burden to the host. In case of [Transparent], no time-consuming tty line discipline is applied for the port

except flow control, thus non-terminal applications such as data acquisition will benefit from it, e.g. gain better throughput and performance.

Response

Three levels, Slow, Normal and Fast, of port response time are designed for your need. Ports with faster response time will consume more host CPU's resource while slower response consumes less resource. The response time for those ports with normal or slow response can be further tuned by the response level in "Performance Tuning" menu. In addition, if the port feature is set to On-board Line Discipline "Disable" and Feature "Terminal", response option will be locked at "Slow" level.

UART FIFO

This feature is set to "Enable" by default and is not able to change.

RTS/CTS Hardware Flow Control

This feature controls the hardware flow control feature. If set to "Disable" (default), CTS signal is not needed for tty port to transfer data and RTS/CTS hardware flow control function in driver is disabled. On the contrary, if set to "Enable", CTS signal is needed for tty port to transfer data and RTS/CTS hardware flow control function in driver is enabled.

Performance Tuning

The utility let you tune the driver to the desired response time for those ports with Resp = Norm or Slow in [Port Feature] sub-menu of Advanced configuration. Ten response time levels (0-9) are available for tuning. The idea is that the faster response time will consume more host CPU resource while slower response consume less resource. If the host CPU is fast enough or a quick response is highly demanded, choosing level 9 would be suitable.

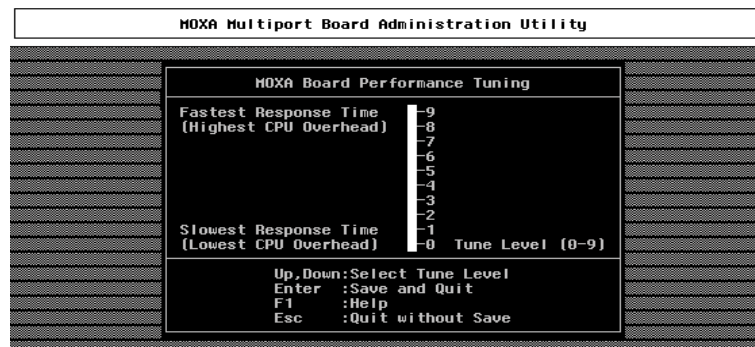

Board Reset

The board reset utility eliminates the need to shut down the UNIX system for re-initializing the Intellio C320Turbo/PCI board with new configuration. Press Enter to start board reset.



However, before the board reset is issued, you must make sure that

1. All enabled ports must be disabled.
2. All processes related to the Intellio C320Turbo/PCI, including getty or tty monitor, are killed.

Once the board is reset, the following message may show if it is successful.

```
MOXA Serial I/O Board (Ver x.x)
Downloading
MOXA-C320Turbo/PCI (MemBank=XX000;BusNo=X;DevNo=X) is found.
```

If one of the following message appears, please see “Troubleshooting” chapter.

```
WARNING! C320Turbo/PCI (XX000;BusNo=X;DevNo=X) not found!
Or ERROR! C320Turbo/PCI (MemBank=XX000) download failed!
```

Driver Removal

If you want to remove the Intellio C320Turbo/PCI device driver and return to your previous system configuration, simply press Enter in this function entry and answer “Y” to confirm. Then the system will be rebuild. This may take some time. If you answer “N”, no action will be taken.

Checking Board Initialization Status

When the system starts up and enters into the multiuser mode, you should see the board initialization status report, which is same as one of the messages described in the “Board Reset” part of previous section.

Setting MOXA Ports to Terminal

Following procedure is how to set the MOXA port to the “Terminal” for login purpose, taking ttya11 as an example,

SCO UNIX/OpenServer/Open Desktop/XENIX

```
# enable /dev/ttya11
```

UNIX SVR4.2 and UnixWare

1. Edit (e.g. use vi editor) the file /etc/inittab.
2. Modify the tty entry from "ma11:23:off:/etc/getty ttya11 9600" to "ma11:23:respawn:/etc/getty ttya11 9600".
3. # init q

Or refer to your UNIX system manuals for how to activate a tty port.

4

Serial Programming Tools

Moxa supports powerful but easy serial programming library and utilities under Windows NT, Windows 95/98 and UNIX. You will greatly save the developing time with the MOXA Serial Programming Tools. The following sections details the installation, the library and the utilities under various O.S. platforms.

Windows NT and Windows 95/98

PComm, the professional serial comm tool for PC, is a software package under **Windows NT and Windows 95/98**, which consists of powerful serial communication library for easy programming in most popular languages, useful utilities such as diagnostic, monitor and terminal emulator, illustrative example programs and comprehensive on-line documents.

The serial communication library is useful for developing a system for data communication, remote access, data acquisition or industrial control in the Windows NT and Windows 95/98 environment, which offers an easier solution compared with the more complex Windows Win32 COMM API.

Installation

To install **PComm**, please run **\Setup.exe** in the diskette. Note that **PComm** diagnostic and monitor utilities are for MOXA boards only. MOXA Windows NT or Windows 95/98 device driver as well as MOXA board are required. The driver are installed separately and detailed in "Software Installation" chapter.

PComm Programming Library

The serial communication library is to assist you to develop programs for serial communications **for any COM port** complying with Microsoft Win32 API. It can ease the implementation of multi-process and multi-thread serial communication programs and hence greatly reduce the developing time.

For complete library function description and example programs for Visual C++, Visual Basic and Delphi, please see help file and example programs in **PComm** directory for more details.

Utilities

The followings are short descriptions of each utility. For details, please see on-line help in the diskette.

Diagnostic (for MOXA boards only)

A convenient diagnostic program provides internal and external testing, such as IRQ, Tx/D/RxD, UART, CTS/RTS, DTR/DSR, DTR/DCD testing, etc., for the MOXA boards and ports to verify correct operation of both the software and hardware.

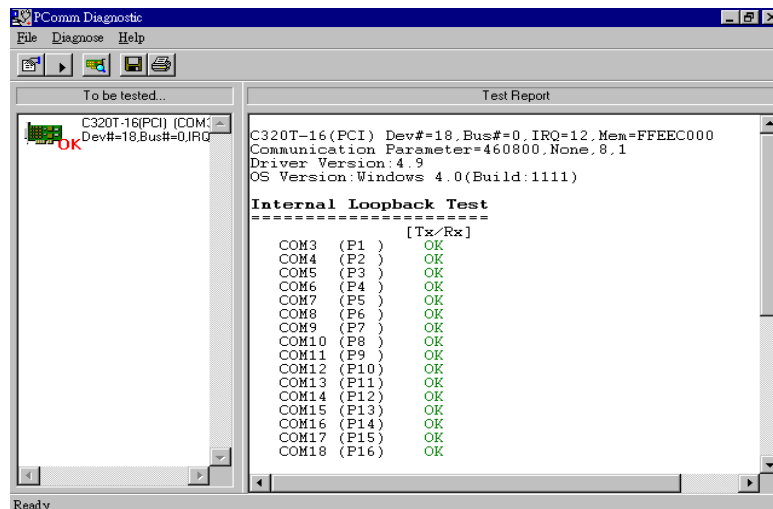

Monitor (for MOXA boards under Windows NT Only)

A useful port status monitoring program allows you to watch the selected MOXA COM ports' data transmitting/receiving throughput and communication line status which are updated and displayed on the screen at every time interval. In addition, you may click on one of the specific displayed port in order to see the current communication parameters and status of that port.

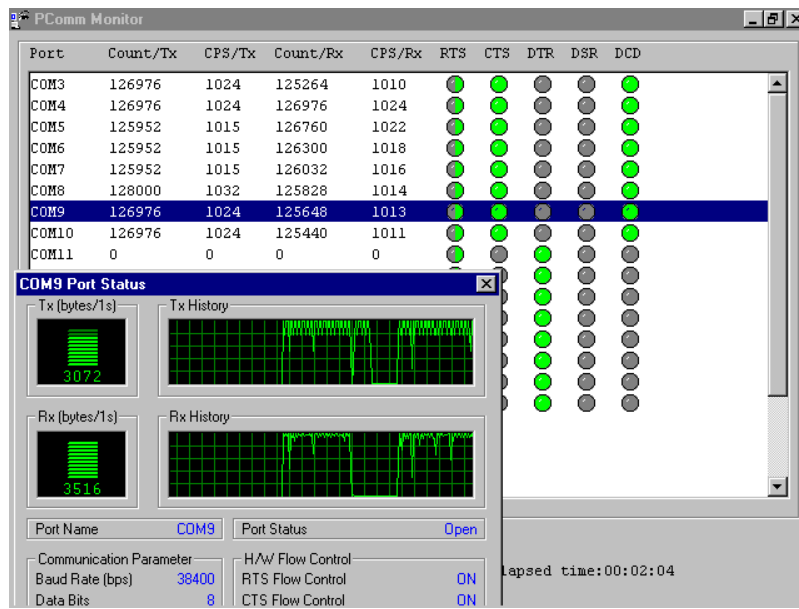

Terminal Emulator

The Terminal Emulator features multi-windows and supports terminal types of VT100 and ANSI. You can transfer data interactively, send pattern periodically or transfer file using ASCII, XMODEM, YMODEM, ZMODEM and KERMIT protocols.

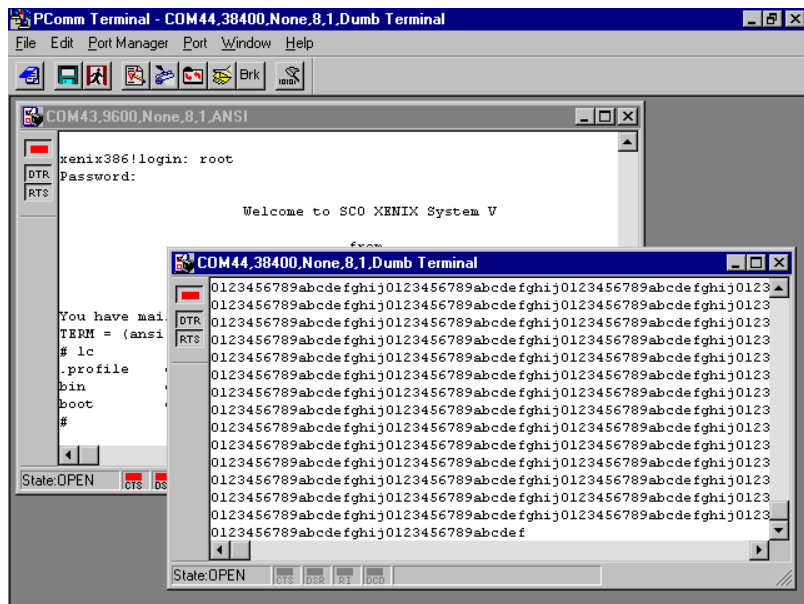

UNIX

Programming the MOXA Ports

The system calls that apply to standard tty port also apply to MOXA port since MOXA port conforms to UNIX tty standard. System calls are like `open()`, `ioctl()`, `read()`, `write()`, `close()`, etc. Please refer to your UNIX Programmer's Reference manual.

However, these system services only provide limited functions and thus may not satisfy the sophisticated programmers's need. In order to fully control the hardware, MOXA supports extended services through `ioctl()` command, which are:

1. MIBUFED (= 0x401) To get byte count in input buffer.
2. MOBUFED (= 0x402) To get byte count in output buffer.
3. MTCRTS (= 0x403) To control RTS output signal.
4. MTC DTR (= 0x404) To control DTR output signal.
5. MLOWATER (= 0x405) To set output buffer low water level.
6. MSTATUS (= 0x407) To read modem line status (CTS/DSR/DCD).
7. MHWFLOW (= 0x40e) To enable/disable the hardware flow control.

The next Section details all the commands.

Extended UNIX `ioctl()` Commands

The following describes the syntax and usage of MOXA extended functions for both non-SVR4.x and SVR4.x UNIX. The variable `moxa_fd` is the returned file descriptor by `open()` a specific MOXA port. For example,

```
int moxa_fd;  
moxa_fd = open("/dev/ttya11", O_RDWR);
```

1. MIBUFED

This function let you know how many bytes queued in input buffer when this function is issued.

Syntax for SCO UNIX/XENIX

```
#define MIBUFED 0x401  
int count; /*number of bytes queued in the buffer */  
  
ioctl(moxa_fd, MIBUFED, &count);
```

Syntax for UNIX SVR4

```
#include <sys/stropts.h>
#include <sys/sysmacros.h>
#define MIBUFED 0x401
struct strioctl ioc;
int count; /*number of bytes queued in the buffer */

ioc.ic_cmd = MIBUFED;
ioc.ic_timeout = 0;
ioc.ic_len = sizeof(int);
ioc.ic_dp = (char *)&count;
ioctl(moxa_fd, I_STR, &ioc);
```

Note: Due to the characteristics of STREAMS driver, the returned count of bytes buffered only reflect the data buffered on MOXA board, not including the data buffered in STREAMS queue. In this case, the count is for reference only. For example, returned count may always be zero, but there still are data buffered in STREAMS queue.

2. MOBUFED

This function let you know the byte count queued in output buffer when this function is issued.

Syntax for SCO UNIX/XENIX

```
#define MOBUFED 0x402
int count; /* number of bytes queued in the output buffer */

ioctl(moxa_fd, MOBUFED, &count);
```

Syntax for UNIX SVR4

```
#include <sys/stropts.h>
#include <sys/sysmacros.h>
#define MOBUFED 0x402
struct strioctl ioc;
int count; /* number of bytes queued in the output buffer */

ioc.ic_cmd = MOBUFED;
ioc.ic_timeout = 0;
ioc.ic_len = sizeof(int);
ioc.ic_dp = (char *)&count;
ioctl(moxa_fd, I_STR, &ioc);
```

Note: See MIBUFED for influence of STREAMS driver.

3. MTCRTS

This function, only valid when hardware flow control is turned off (see MHWFLOW), is used to turn RTS on or off.

Syntax for SCO UNIX/XENIX

```
#define MTCRTS      0x403
#define TurnON      1
#define TurnOFF     0
```

```
ioctl(moxa_fd, MTCRTS, TurnON);
ioctl(moxa_fd, MTCRTS, TurnOFF);
```

Syntax for UNIX SVR4

```
#include <sys/stropts.h>
#include <sys/sysmacros.h>
#define MTCRTS      0x403
#define TurnON      1
#define TurnOFF     0
struct strioctl
int    setting;
```

```
setting = TurnON /* or TurnOFF */;
ioc.ic_cmd = MTCRTS;
ioc.ic_timeout = 0;
ioc.ic_len = sizeof(int);
ioc.ic_dp = (char *)&setting;
ioctl(moxa_fd, I_STR, &ioc);
```

4. MTCDTR

This function, only valid when hardware flow control is turned off (see MHWFLOW), is used to turn DTR on or off.

Syntax for SCO UNIX/XENIX

```
#define MTCDTR      0x404
#define TurnON      1
#define TurnOFF     0
```

```
ioctl(moxa_fd, MTCDTR, TurnON);
ioctl(moxa_fd, MTCDTR, TurnOFF);
```

Syntax for UNIX SVR4

```
#include <sys/stropts.h>
#include <sys/sysmacros.h>
#define MTCDDR 0x404
#define TurnON 1
#define TurnOFF 0
struct strioctl
int          setting;

setting = TurnON /* or TurnOFF */;
ioc.ic_cmd = MTCDDR;
ioc.ic_timeout = 0;
ioc.ic_len = sizeof(int);
ioc.ic_dp = (char *)&setting;
ioctl(moxa_fd, I_STR, &ioc);
```

5. MLOWATER

Sometimes the application software may not be able to write any further data to the output buffer because of the output buffer being full. The application has to wait until the output buffer has 'enough space' again. The criteria to tell if the output buffer has 'enough space' is that whether the output buffer reached its 'low water' level. That is the output buffer will accept further data only when the 'low water' level is reached.

If the 'low water' value is relatively small, you may find that the output buffer become empty before you write another block of data (this is quite possible because UNIX is time-sharing multitasking environment). This will result in discontinuous data transmission. In a timeout-sensitive application, e.g. facsimile (FAX) transmission, discontinuous data may falter the operation.

The default 'low water' is 512 bytes. You can enlarge it but better not exceed one half of the output buffer. Each port's output buffer depends on the number of total ports. See below.

Model	Output buffer/each port
C320Turbo/PCI w/8 ports	32K bytes
C320Turbo/PCI w/16ports	16K bytes
C320Turbo/PCI w/24ports	8K bytes
C320Turbo/PCI w/32ports	4K bytes

Syntax for SCO UNIX/XENIX

```
#define MLOWATER    0x405
int    lowater;    /* low water value of output buffer (default = 512 bytes) */

ioctl(moxa_fd, MLOWATER, lowater);
```

Syntax for UNIX SVR4

```
#include    <sys/stropts.h>
#include    <sys/sysmacros.h>
#define MLOWATER    0x405
struct strioctl    ioc;
int lowater;    /* low water value of output buffer (default = 512 bytes) */

ioc.ic_cmd = MLOWATER;
ioc.ic_timeout = 0;
ioc.ic_len = sizeof(int);
ioc.ic_dp = (char *)&lowater;
ioctl(moxa_fd, I_STR, &ioc);
```

6. MSTATUS

This function is used to know the RS-232 line status (CTS/DSR/DCD).

Syntax for SCO UNIX/XENIX

```
#define MSTATUS    0x407
int    status;    /* status = RS-232 line status*/
                /* bit0 – CTS (1:on, 0:off)*/
                /* bit1 – DSR (1:on, 0:off)*/
                /* bit2 – DCD (1:on, 0:off)*/

ioctl(moxa_fd, MSTATUS, &status);
```

Syntax for UNIX SVR4

```
#define MSTATUS    0x407
#include    <sys/stropts.h>
#include    <sys/sysmacros.h>
struct strioctl    ioc;
int    status;    /* status = RS-232 line status*/
                /* bit0 – CTS (1:on, 0:off)*/
                /* bit1 – DSR (1:on, 0:off)*/
                /* bit2 – DCD (1:on, 0:off)*/

ioc.ic_cmd = MSTATUS;
ioc.ic_timeout = 0;
ioc.ic_len = sizeof(int);
ioc.ic_dp = (char *)&status;
ioctl(moxa_fd, I_STR, &ioc);
```

7. MHWFLOW

This function is used to enable/disable hardware flow control. The first open() function of a port will set the hardware flow control bits on or off depending on the [RTS/CTS Hardware Flow Control] configuration in **mxadm**. However, you might want to control the DTR or RTS signal, thus the RTS flow control bit should be turned off (HWFlowControlOff) in order to take over the control of DTR or RTS signal via function MTCRTS or MTCDTR. MTCRTS and MTCDTR can be effective only after the RTS flow control bit is turned off.

Syntax for SCO UNIX/XENIX

```
#define MHWFLOW          0x40e
#define HWFlowControlOff 0x00
#define CTSFlowControlBitOn 0x01
#define RTSFlowControlBitOn 0x02
#define HWFlowControlOn  0x03

ioctl(moxa_fd, MHWFLOW, CTSFlowControlBitOn);
ioctl(moxa_fd, MHWFLOW, RTSFlowControlBitOn);
ioctl(moxa_fd, MHWFLOW, CTSFlowControlBitOn | RTSFlowControlBitOn);
```

Syntax for UNIX SVR4

```
#include <sys/stropts.h>
#include <sys/sysmacros.h>

#define MHWFLOW          0x40e
#define HWFlowControlOff 0x00
#define CTSFlowControlBitOn 0x01
#define RTSFlowControlBitOn 0x02
#define HWFlowControlOn  0x03
struct strioctl
int

setting = CTSFlowControlbitOn;
ioc.ic_cmd = MHWFLOW;
ioc.ic_timeout = 0;
ioc.ic_len = sizeof(int);
ioc.ic_dp = (char *)&setting;
ioctl(moxa_fd, I_STR, &ioc);
```

Utilities

You can use the administration utility, **mxadm**, to **monitor port activity** and to do **terminal emulation**, which are details as follows.

Port Monitoring

This utility gives you a quick view about all the MOXA ports' activities. You can easily learn each port's total received/transmitted (Rx/Tx) character count since the time when the monitoring is started. Rx/Tx throughputs per second are also reported in interval basis (e.g. the last 5 seconds) and in average basis (since the time the monitoring is started). You can reset all ports' count by <HOME> key. <+> <-> (plus/minus) keys to change the displaying time interval.

MOXA Multiport Board Administration Utility						
Time[00:00:46]	Board #1	Type: c320 Turbo/PCI	Interval 3 sec <+/->			
Device name	Char Count (bytes)	Rx		Tx		
		Throughput(BPS) Interval	Average	Char Count (bytes) Interval	Throughput(BPS) Average	
ttya1/A11	907776	21760	20172	923457	22335	20521
ttya12/A12	908032	21760	20178	888289	22335	19739
ttya13/A13	914944	23978	20332	924051	22303	20534
ttya14/A14	914688	23978	20326	922289	22181	20495
ttya15/A15	908288	21760	20184	927333	22565	20607
ttya16/A16	908032	21760	20178	888068	22232	19734
ttya17/A17	914944	23978	20332	921153	21919	20470
ttya18/A18	907776	21760	20172	924483	22618	20544

PgUp, PgDn:More Ports Home:Reset Count Esc:Exit Enter:Port Status

Press Enter on the port, that the cursor stays, to view the port's communication parameters, signal status, and input/output queue.

MOXA Multiport Board Administration Utility					
Time[00:01:25]		Board #1 Type: C320 Turbo/PCI		Interval 3 sec <+/->	
Device name	Char Cou (bytes)	Port Status		Tx Throughput(BPS)	
		Device Name		Interval	Average
ttya11/A11	17520	ttya11/A11	Baud Rate 110	13901	20560
ttya12/A12	17523		Parity None	21924	20418
ttya13/A13	17525		Data Bits 8	33162	20844
ttya14/A14	17589		Stop Bits 1	32783	20826
ttya15/A15	17525		CTS 0N	21919	20853
ttya16/A16	17523		DSR 0N	22340	20429
ttya17/A17	17592		DCD 0N	22677	20854
ttya18/A18	17520		Input Queue 6251	13895	20564
			Output Queue 22975		
PgUp, PgDn: More Port		PgDn: Next PgUp: Prev		Enter: Port Status	
		Esc: Exit			

Terminal Emulator

This utility provides data sending and receiving ability of all tty ports, especially for MOXA ports. It is quite useful for testing simple application, for example, sending AT command to a modem connected to the port or used as a terminal for login purpose. Note that this is only a dumb terminal emulation without handling full screen operation. Besides, data scope function with pattern/file transfer is provided.

Dumb Terminal Emulation		Ctrl-N: menu
Terminal Emulator Menu		
Communication Setup		
Terminal		
Advance Transfer Modes		
Enter: Select Esc: Exit		

Serial Programming Tools

1. Select and Press Enter on item “**Communication Setup**” to setup up all the communication parameters for connection.

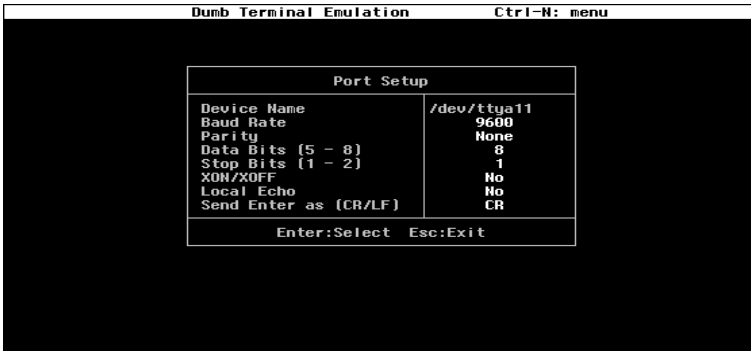

2. Select and enter “**Terminal**” to enter terminal emulation. Or select and enter “**Advanced Transfer Modes**” to perform pattern or file transfer with protocols such as ZModem.

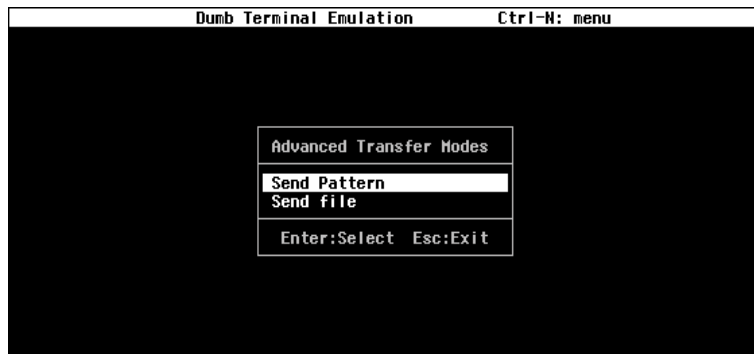

Connection Option and Cable Wiring

In data communications, the term **DTE** is Data Terminal Equipment like terminal or PC COM1/2. The term **DCE** is Data Communication Equipment like modem. Please check the precise pinouts, the following pinouts are typical examples.

The UART modules for Desktop option provide both RS-232 and RS-422 connection options, depending on the models of modules you choose. The Basic/Extensive modules for Rackmount option provide merely RS-232 connection options. However, all the modules can use together with MOXA A50/A51 to obtain RS-422/RS-485 capabilities (See MOXA A50/A51 User's Manual for details.)

RS-232 Cable Wiring for C32045T/C32047T/C32071T

The following RS-232 UART Modules are designed for Intellio C320Turbo/PCI.

C32045T : UART Module providing 8 female RS-232 ports.

C32047T : UART Module providing 8 male RS-232 ports.

C32071T : UART Module providing 8 female RS-232 ports with 2000V surge protection which can protect ports from lightning.

There are two types of connectors, **female** or **male**, for RS-232 UART Modules. You have to identify the type of connectors and apply the correct cable wiring.

**UART Module C32045T/71T
DB25 Female Connector**

2	RxD
3	TxD
4	CTS
5	RTS
6	DTR
7	GND
8	DCD
20	DSR

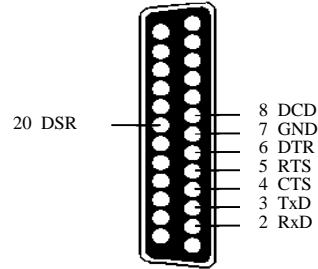

**UART Module C32047T
DB25 Male Connector**

2	TxD
3	RxD
4	RTS
5	CTS
6	DSR
7	GND
8	DCD
20	DTR

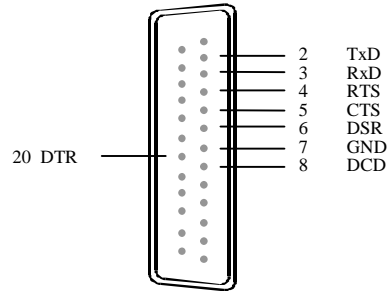

Type 1: Connecting UART Module to a DTE device.

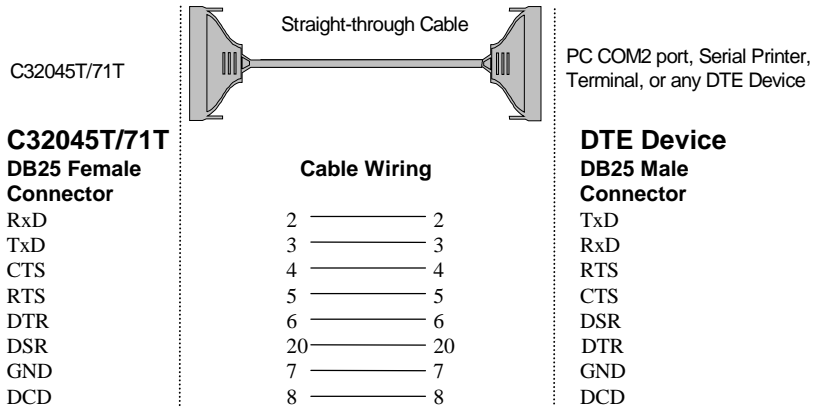

Connection Option and Cable Wiring

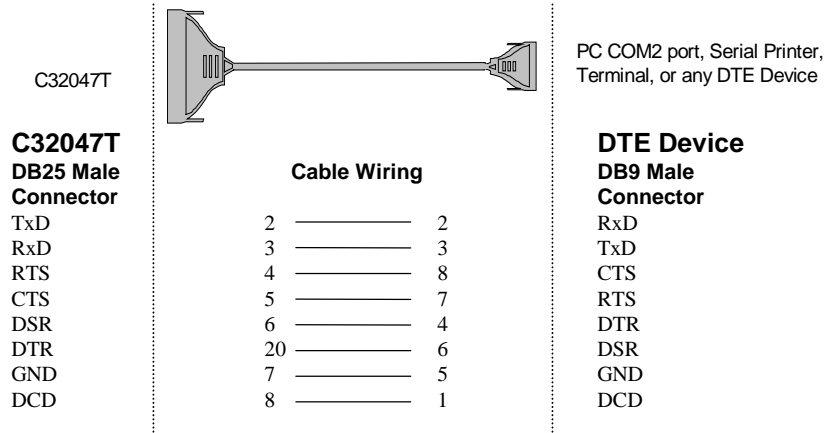
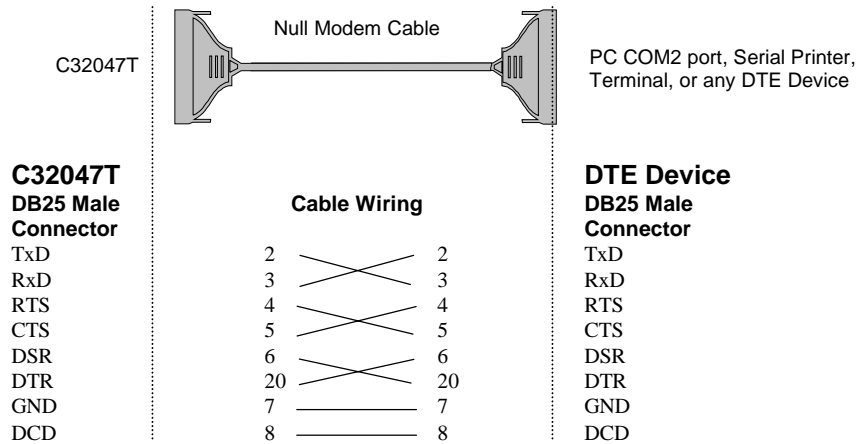

Type 2: Connecting UART Module to a DCE device.

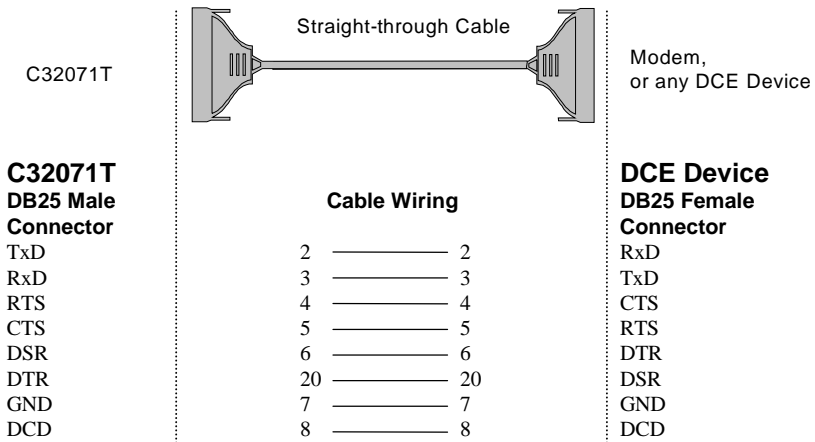
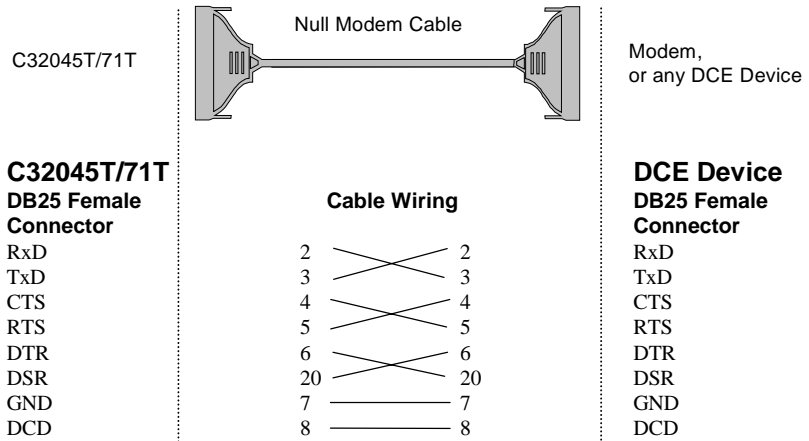

Connection Option and Cable Wiring

Type 3: Connecting UART Module to a DTE device with 3-pin wiring.

If the “**Hardware flow control**” feature is set to “**ON**”, you must loop back (or short) the RTS with CTS and DSR with DTR, DCD on MOXA site, indicated in dash-lines of the following diagrams. If the “**Hardware flow control**” feature is set to “**OFF**”, you could just leave RTS, CTS, DSR, DTR, DCD open, ignoring the connection indicated in dash-lines.

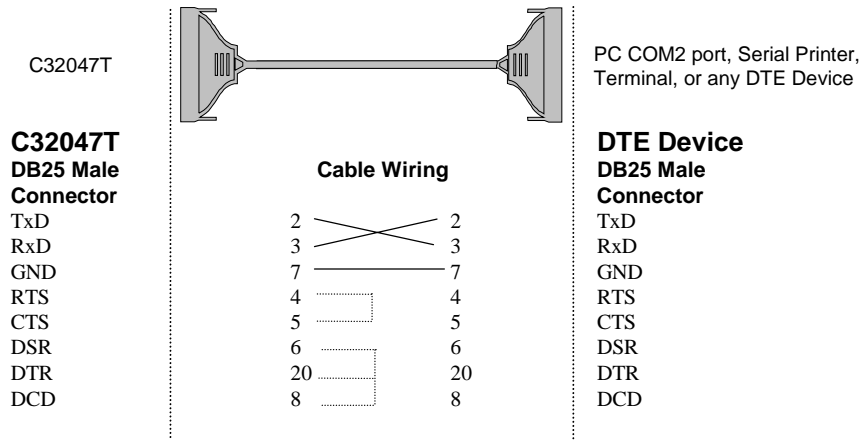
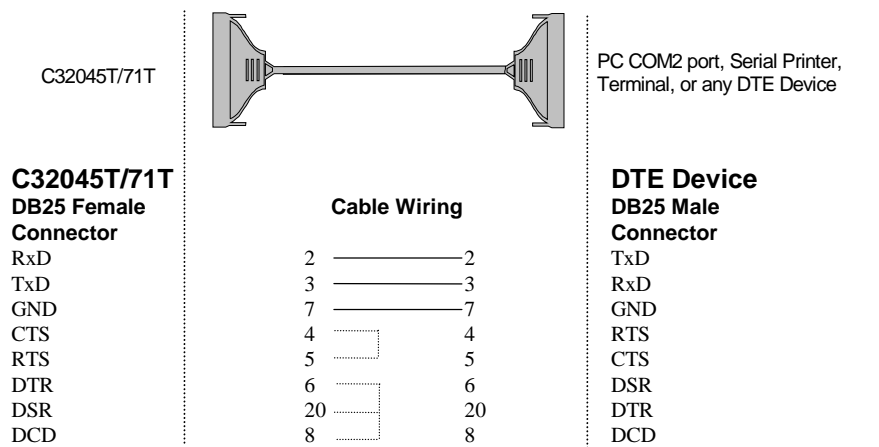

C32047T

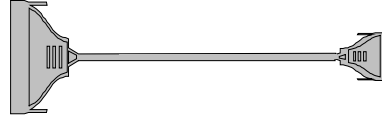

PC COM2 port, Serial Printer,
Terminal, or any DTE Device

**C32047T
DB25 Male
Connector**

TxD
RxD
GND
RTS
CTS
DSR
DTR
DCD

Cable Wiring

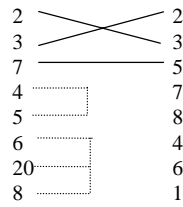

**DTE Device
DB9 Male
Connector**

RxD
TxD
GND
RTS
CTS
DTR
DSR
DCD

RS-422 Cable Wiring for C32061T/C32065T

The following RS-422 UART Modules are designed for Intellio C320Turbo/PCI.

C32061T: UART Module providing 8 female RS-422 DB25 ports without isolation protection.

C32065T: UART Module providing 8 female RS-422 DB25 ports with 2000V isolation protection which can prevent damage caused by high potential voltage.

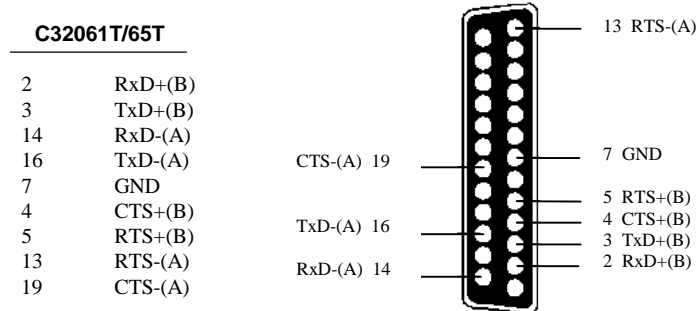

 **The DTR, DSR and DCD signal lines (not shown) of the C32061T/C32065T are internally shorted by design to meet certain software requirements.**

The RS-422 transmission distance can reach as long as 4000ft. The connection box needs an external power adapter to supply 5V DC power. Either 110V or 220V AC power adapter is selectable.

The followings are operation modes for RS-422:

RS-422 Point-to-point

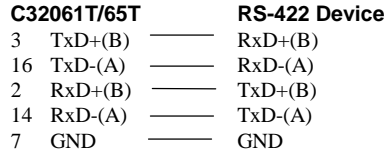

RS-422 Broadcasting

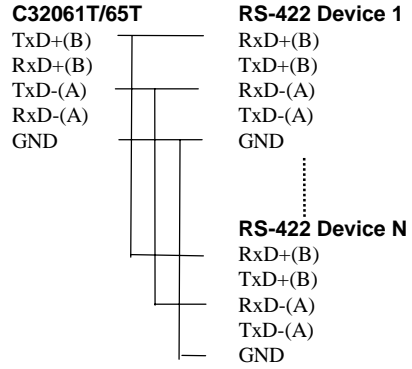

RS-422 with Handshaking

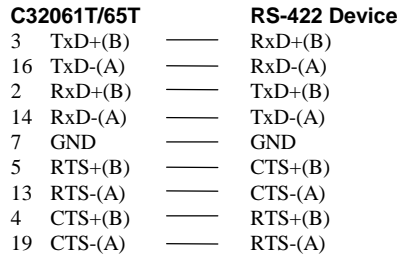

RS-422 Impedance Matching

When an electrical signal travels through two different resistance junctions in a transmission line, the mismatch will sometimes cause signal reflection. Signal reflection causes signal distortion, which in turn will contribute communication errors. The solution to this problem is to establish the same impedance at the line ends as in the line itself by terminating them with resistors.

It is normally sufficient when the value of the termination resistor equals the characteristic impedance of the transmission line. The resistors should be added near the receiving side. See below.

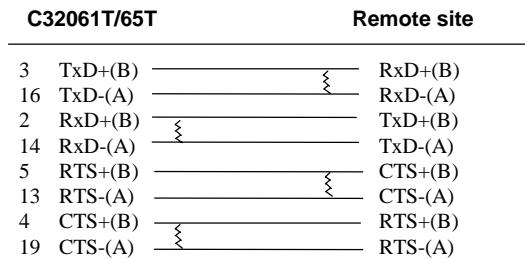

Note:

1. ⚡ stands for termination resistor near the receiving side.
2. The suggested termination resistor for AWG #26 cable is 100 ohm.
3. The suggested termination resistor for phone cable is 600 ohm.

RS-232 Cable Wiring for C32080T/81T/82T/83T & CN20040

For Basic/Extensive Modules, only RS-232 interface with RJ-45 female connector is supported. A 1.5-meter male RJ-45 to male DB25 RS-232 testing cable, **CN20040**, is provided with shipment of the Basic Module.

The following RS-232 Basic Modules are designed for Intellio C320Turbo/PCI.

C32080T : Basic Module providing 8 female RS-232 ports.

C32081T : Basic Module providing 16 female RS-232 ports.

The following RS-232 Extensive Modules are designed for Intellio C320Turbo/PCI.

C32082T : Extensive Module providing 8 female RS-232 ports.

C32083T : Extensive Module providing 16 female RS-232 ports.

C32080T/81T/82T/83T RJ-45 Jack	
Pin	Signals
1	DCD
2	DSR
3	RTS
4	GND
5	TxD
6	RxD
7	GND
8	CTS
9	DTR
10	-

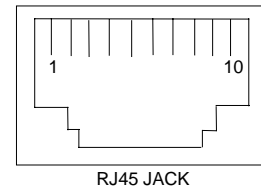

RJ45 JACK

Connection Option and Cable Wiring

Type 1: Connecting Basic/Extensive Module to a DTE device.

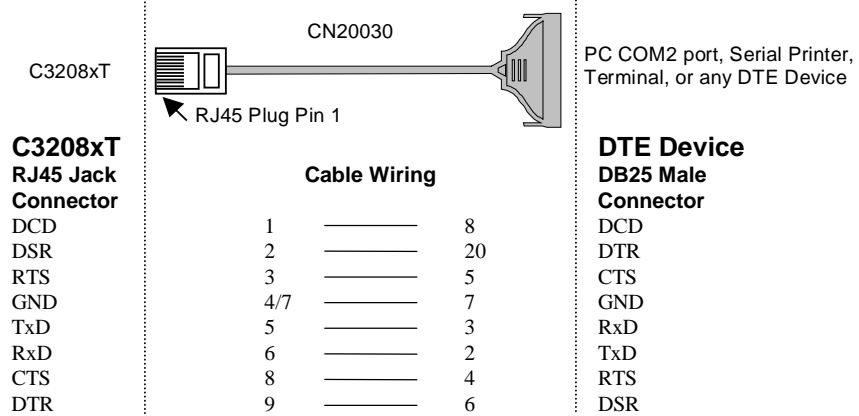

For Rackmount option, this RJ45 to female DB25 RS-232 testing cable (**CN20030**) is available from Moxa.

4/7 means either line 4 or line 7 can be used for GND.

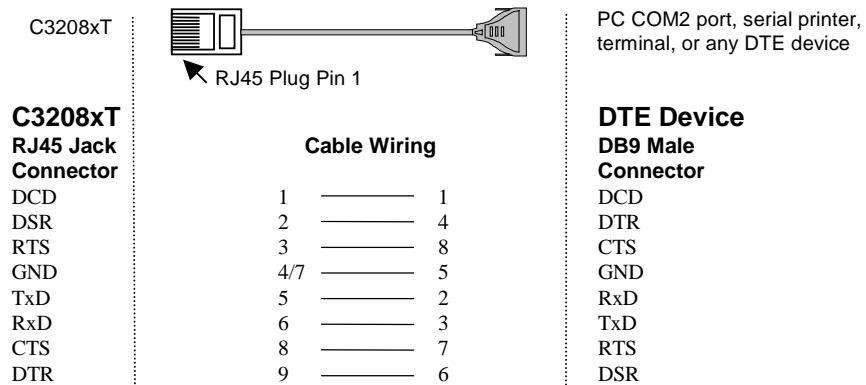

4/7 means either line 4 or line 7 can be used for GND.

Type 2: Connecting Basic/Extensive Module to a DCE device.

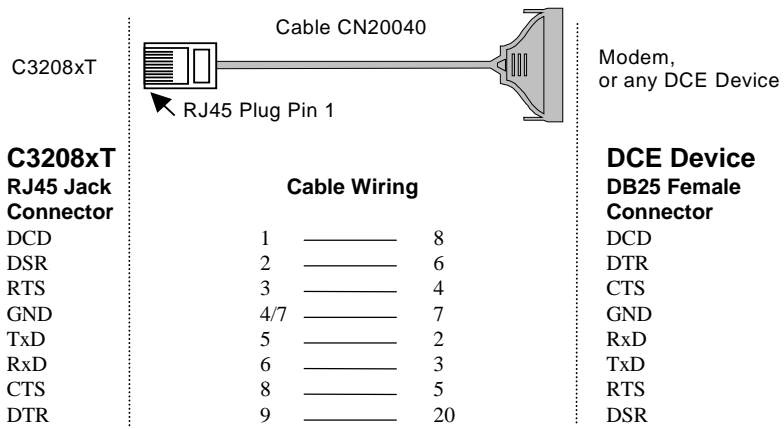

 For Rackmount option, this RJ45 to male DB25 RS-232 testing cable (CN20040) comes with the Basic Module and is provided for testing.

 **4/7** means either line 4 or line 7 can be used for GND.

Connection Option and Cable Wiring

Type 3: Connecting Basic/Extensive Module to a DTE device with 3-pin wiring.

If the “**Hardware flow control**” feature is set to “**ON**”, you must loop back (or short) the RTS with CTS and DSR with DTR, DCD on MOXA site, indicated in dash-lines of the following diagrams. If the “**Hardware flow control**” feature is set to “**OFF**”, you could just leave RTS, CTS, DSR, DTR, DCD open, ignoring the connection indicated in dash-lines.

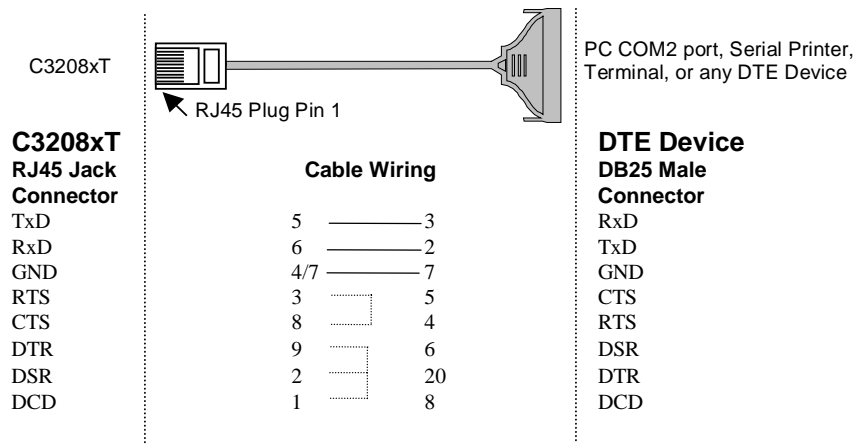

4/7 means either line 4 or line 7 can be used for GND.

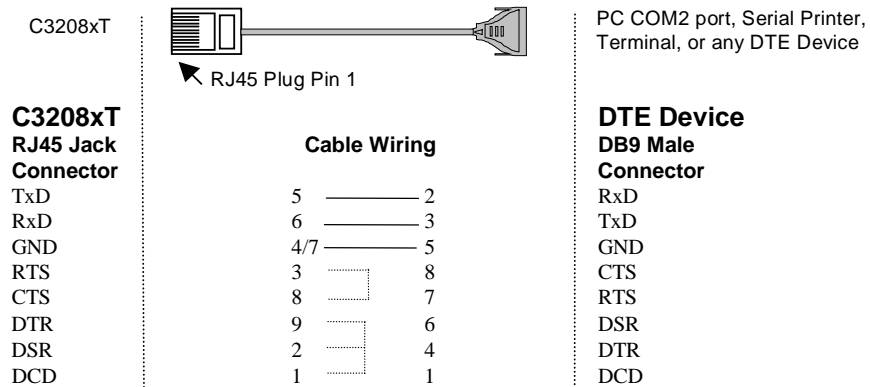

4/7 means either line 4 or line 7 can be used for GND.

C32020T Link Cable

There are two different types of link cables: **25-signal-pin link cable** and **10-signal-pin link cable**. The former is used when there is no external power applied to the external module (CPU/Basic Module). The latter is used when the external power is applied to the external module (CPU/Basic Module) if you have chosen to use **Long Rang Extension Kit**.

25-signal-pin Link Cable (standard)

The factory-supplied 2-meter link cable (the one with 25 signal pins) is used only when you are NOT using the external power adapter. Pin assignments are given below for this 25-pin link cable.

Warning!	Do not use the factory-supplied 2-meter link cable (with 25 signal pins) and the external power adapter at the same time, otherwise the Control Board or CPU/Basic Module may be seriously damaged.
-----------------	---

Pin No.	Signal	Pin No.	Signal
1	GND	14	CLK-
2	DX+	15	FSX+
3	DR+	16	FSR+
4	GND	17	GND
5	GND	18	GND
6	GND	19	GND
7	-12V	20	+12V
8	+5V	21	+5V
9	+5V	22	+5V
10	+5V	23	+5V
11	CLK+	24	FSX-
12	FSR-	25	DR-
13	DX-		

10-signal-pin Link Cable (for long range extension only)

If the external power adapter is applied to the CPU/Basic Module, you will need to use the 10-pin cable accompanying with the Long Range Extension Kit. The Control Board to CPU/Basic Module should have only 10 signal pins with the following pinouts.

Warning! Make the link cable carefully and precisely according to the following pinout, otherwise you will risk damaging the Control Board and CPU/Basic Module.

Pin No.	Signal	Pin No.	Signal
2	DX+	14	CLK-
3	DR+	15	FSX+
11	CLK+	16	FSR+
12	FSR-	24	FSX-
13	DX-	25	DR-

 You can connect the existing 10-signal-pin cable to a 25-signal-pin cable to form a longer 2-segment cable to extend the connection distance up to 100 meters (328 ft).

Troubleshooting

General Troubleshooting

Common Intellio C320Turbo/PCI problems and possible solutions are listed below, in addition to those operating systems specific ones. If you still have problems, contact your dealer or Moxa for help. Or report it using “**Problem Report Form**” at the end of this manual to your dealer at once for technical support.

1. MOXA PCI board can not be detected by the MOXA driver while installing the driver.

Hardware causes and solutions:

- a. The board is not installed or missing (absent). Please install it.
- b. The board is not properly plugged in the system. If that is the case, then re-install the board and make sure that it fits well in a 32-bit PCI slot this time. Sometimes the slot for plugging board is bad. In this case, please try other slots until a good one is found.
- c. Your mother board does not have vacant IRQ for the Intellio C320Turbo/PCI. Please enter BIOS and make sure there are available IRQ in PCI/PnP setting.

2. MOXA board and driver activated but can not transfer (transmitting/receiving) data.

Hardware Causes and Solutions:

- a. Check if wrong cable wiring. Refer to the “Connection Option and Cable Wiring” chapter for precise pinouts of the connector type you are using.
- b. Cable, external modules or board is defective. You may use other port, cable

or box or board to verify. In addition, PComm utility “Diagnostic” for Windows NT and Windows 95/98 is good for testing MOXA board and port condition. If the report of diagnostic shows error, replace the error component.

Software Causes and Solutions:

- a. Intellio C320Turbo Series will check line status (CTS) before it sends data out if RTS/CTS flow control feature is set to “Enable” in configuration or application program. Please see the “Connection Options and Cable Wiring” chapter for proper wiring. Check the line status of the suspected port using the diagnostic LED indicators on the mini tester.
 - b. Perhaps the application controlling the board is not correctly written according to the corresponding API of the operating system. To verify, please run existing and known good application or Moxa provided utility. For example, under Windows NT and Windows 95/98, PComm utility “Terminal emulator” or “Hyperterminal” is good for testing COM ports. Under UNIX, “Terminal emulator” in the MOXA administration utility “mxadm” and “stty”, “cat”, or “getty” are existed programs for testing tty port.
- 3. “CPU/Basic Module not found” message appears. Or CPU/Basic Module can not download firmware from the Control Board.**

Hardware Causes and Solutions:

- a. Switch off the CPU/Basic Module. Check that the connection cable between the CPU/Basic Module and the Control Board is correct and firmly connected on both sides. Switch on the CPU/Basic Module, then power on the Control Board system to wait until the LED display of CPU/Basic Module reads “Ld”.
- b. Sometimes it happens when the total consumption of power in the system is higher than the power adapter can provide. Especially when many interface boards including MOXA board(s) are plugged in the system. It is recommended to replace the current power adapter with higher watt one. Or choose the external power option if Intellio C320Turbo/PCI is used.
- c. If all the possible methods fail, the CPU/Basic Modules might be defective. Please check the module(s) **one at a time** in the system to find out the defective one.

4. Error messages appear on CPU/Basic Module LED display.

Any of the following messages means failure of the Intellio C320Turbo/PCI initialization.

E0: CPU/Basic Module ROM error.

E1: CPU/Basic Module RAM error.

E2: No UART Module present.

E4: The power to the CPU/Basic Module has been switched off and on swiftly, or some Module is missing during the power-off time.

E5: The connection between Modules is loose or broken.

A1: CPU/Basic Module execution failure.

A2: CPU/Basic Module can not communicate with Control Board.

10: The first UART Module initialization failure.

20: The second UART Module initialization failure.

30: The third UART Module initialization failure.

40: The fourth UART Module initialization failure.

Hardware Causes and Solutions:

If the error message persists after check, return the unit for repair.

As “E0”, “E1” or “A1” occurs, usually you have to turn off and on the CPU Module. If problem persists, the CPU Module might be defective.

As “E2” occurs, turn off the CPU Module, firmly connect the UART Modules, and turn the power back on.

As “E4” occurs, usually you have to turn off the CPU/Basic Module, then turn on at least time interval 3 seconds. Or check if the total number of ports (or modules) is correct or not.

As “E5” occurs, it may indicate that the cables between modules should be fastened carefully.

As “A2” occurs, check the link between CPU Module and Control Board is fastened carefully.

As “10”, “20”, “30” or “40” occurs, make sure the connection between modules is proper.

-
5. Upon system startup or driver initialization, the “Number of ports mismatch” message appears.

Hardware Causes and Solutions:

The total number of ports installed is less than that of configured.

- a. Shut off the system and check all modules and their connections. Make sure that all the module(s) is(are) fastened properly.
- b. Run the board configuration program to check the board configuration. For Intellio C320Turbo/PCI, connect the CPU/Basic Module with proper number of UART/Extensive Module(s) as configured in configuration program.
- c. If all the possible methods fail, one of the module(s) might be defective. Please check the module(s) **one at a time** in the system to find out the defective one.

Windows NT

This section is specific for troubleshooting under Windows NT. For general problems and solutions, please see the previous section, “General Troubleshooting”.

1. **After system starts, error message “MOXA C320Turbo/PCI Multiport Board #1 addr(XXX): CPU/Basic Module not found!” appears in Event Log.**

Shutdown the system first and refer to the problem 3 for solutions in the previous section, “General Troubleshooting”.

2. **After system starts, error message “MOXA C320Turbo/PCI Multiport Board #1 addr(XXX): number of UART Modules mismatch!” appears in Event Log.**

Make sure that all the modules are fastened properly. Or open [Control Panel], select the [Network] icon, [Adapters] tab, and select “MOXA Intellio C320Turbo Series Adapter” item in the “Installed Adapter Cards:” and click on the [Properties...] button to start the “MOXA Configuration Panel” dialog box, and make sure to connect the CPU Module with proper number of UART Module(s) as configured.

3. **After system starts, error message “MOXA C320Turbo/PCI Multiport Board #1 addr(XXX): number of ports mismatch!” appears in Event Log.**

Make sure that all the module(s) is(are) fastened properly and the ports installed are the same as configured. Or open [Control Panel], select [Network] icon, then [Adapters] tab, select “MOXA Intellio C320Turbo Series Adapter” item in the “Installed Adapter Cards:” and click on the [Properties...] button to start the “MOXA Configuration Panel” dialog box, and make sure to connect the CPU Module with proper number of UART Module(s) as configured.

4. **After system starts, error message “MOXA C320Turbo/PCI Multiport Board #1 addr(XXX): IRQ test failure!” appears in Event Log.**

This indicates MOXA board is found but the IRQ is conflicting with other adapter. Please make sure there is no conflict with other adapter's IRQ. Check the PCI BIOS IRQ setting first. Make sure IRQ is available.

-
- 5. After system starts, error message “MOXA C320Turbo Multiport Board #1 addr(XXX): CPU/Basic module download failure!” appears in Event Log.**

Shutdown the system first and refer to the problem 3 for solutions in the previous section, “General Troubleshooting”.

- 6. Windows NT system panic (blue screen).**

The possible reason is IRQ conflict with other ISA Bus adapters like LAN and SCSI board, RAID controller or system BIOS.

- 7. Error message “C320tnt.cod file not found!” appears.
Error message “C320tnt.cod file length is wrong!” appears.
Error message “C320tnt.cod file data content error!” appears.**

It means something is wrong with driver installation or the file has been deleted accidentally or corrupted somehow. To recover, simply reinstall the driver.

Windows 95/98

This section is specific for troubleshooting under Windows 95/98. For general problems and solutions, please see the previous section, “General Troubleshooting”.

1. **Error message “MOXA C320Turbo/PCI (BusNo=xx, DevNo=xx) at base memory [XXX] download failure!” appears.**

Shutdown the system first and refer to the problem 3 for solutions in the previous section, “General Troubleshooting”.

2. **Error message “MOXA C320Turbo/PCI (BusNo=xx, DevNo=xx) at base memory [XXX] number of UART Modules mismatch!” appears.**

Make sure that all the module(s) is(are) fastened properly. Or click on the Taskbar [Start] button, [Programs] menu, [MOXA Utilities] menu, [MOXA Configuration Panel] icon, and connect the CPU Module with proper number of UART Module(s) as configured.

3. **Error message “MOXA C320Turbo/PCI (BusNo=xx, DevNo=xx) at base memory [XXX] ports number mismatch!” appears.**

Make sure that all the Module(s) is(are) fastened properly and the ports installed are the same as configured. Or click on the Taskbar [Start] button, [Programs] menu, [MOXA Utilities] menu and [MOXA Configuration Panel] icon, and connect the Basic Module with proper number of Extensive Module(s) as configured.

4. **Error message “MOXA C320Turbo/PCI (BusNo=xx, DevNo=xx) at base memory [XXX] CPU/Basic Module not found!” appears.**

Shutdown the system first and refer to the problem 3 for solutions in the previous section, “General Troubleshooting”.

5. **Error message “MOXA C320Turbo/PCI (BusNo=xx, DevNo=xx) at base memory [XXX] CPU/Basic Module download failure!” appears.**

Shutdown the system first and refer to the problem 3 for solutions in the previous section, “General Troubleshooting”.

6. Error message “C320Turbo/PCI (BusNo=xx, DevNo=xx) at base memory [XXX] interrupt failure!” appears.

This indicates MOXA board is found but the IRQ is conflicting with other adapter. Make sure there is no conflict with other adapter's IRQ. Check the PCI BIOS IRQ setting and make sure IRQ is available.

**7. Error message “C320twin.cod file not found!” appears.
Error message “C320twin.cod file length is wrong!” appears.
Error message “C320twin.cod file data content error!” appears.**

It means something is wrong with driver installation or the file has been deleted accidentally or corrupted somehow. To recover, simply reinstall the driver.

UNIX

This section is specific for troubleshooting under UNIX. For general problems and solutions, please see the previous “General Troubleshooting” section.

1. During system reboots, error message “WARNING! C320Turbo/PCI (XX000;BusNo=X;DevNo=X) not found!” appears.

The possible cause is memory conflict or defective board. Please shutdown the system first, and then refer to the problem **1** for solutions in the previous “General Troubleshooting” section.

2. During system reboots, error message “ERROR! C320Turbo/PCI (XX000; BusNo=X;DevNo=X) download failed!” appears.

The possible cause is memory conflict or defective board. Please shutdown the system first, and then refer to the problem **1** for solutions in the previous “General Troubleshooting” section.

3. MOXA port responds too slowly or abnormal key operation.

The applications are not compatible with the Intellio C320Turbo/PCI On-board line discipline. The only way to work it around is to set On-board line discipline feature to “Disable” in [Board] sub-menu of Advanced configuration (the “UNIX” section of the “Software Installation” chapter).

- 4. When respawning quite a few number of tty ports, the following error messages appear: “Time out table overflow”, “File table overflow”, “Region table overflow”.**

The above error messages imply that the system resources are exhausted. You should tune the kernel parameters to a larger value and rebuild the kernel to be able to accommodate the new configuration. Refer to UNIX system manual about how to tune the parameters and rebuild kernel.

“Time out table overflow” :NCALL parameter too small.
“File table overflow” :NFILE or NINODE parameter too small.
“Region table overflow” :NREGION or NPROC parameter too small.

- 5. The newly rebuilt kernel could not boot.**

The Intellio C320Turbo/PCI driver might not be built into the new kernel correctly.

- a. Please use the last good kernel backup to boot again. The kernel backup in SCO UNIX is **/unix.moxa** while in UNIX SVR4.2 **/stand/unix.moxa**.
 - b. Then remove the Intellio C320Turbo/PCI driver. Refer to “UNIX” section of “Software Installation” chapter for driver removal.
 - c. Re-install the Intellio C320Turbo/PCI driver once more.
- 6. When using MOXA port for PPP/SLIP connection, what should the “On Board Line Discipline” feature be set to?**

Set to “Disable”. Otherwise the PPP/SLIP connection will fail.

Appendix

Technical Reference

Specifications

System

- ❖ Up to 32 serial ports per Control Board
- ❖ Up to 4 Control Boards per PC system for a total of 128 ports
- ❖ Supports device drivers for most popular operating systems. See the driver support list below:

	<u>C320Turbo/PCI</u>
Windows NT	✓
Windows 95/98	✓
SCO UNIX/OpenServer	✓
UNIX SVR4.2	✓
XENIX	✓
Linux2.0.x/2.2.x	R

✓ : Driver supported by Moxa and shipped with product

R : By request

Note: Download the newest drivers from the MOXA FTP service

Control Board

- ❖ 57 MHz TMS320BC52 processor
- ❖ 512 KB dual-ported RAM, maps to 16K Bytes system RAM
- ❖ Base addresses from 1M to 4G
- ❖ Selectable IRQ: 2 (or 9), 3, 4, 5, 7, 10, 11, 12, or 15
- ❖ Half-size board, ASIC and SMT design
- ❖ CPU/Basic Module can be located up to 100 m (328 ft) away from the host computer

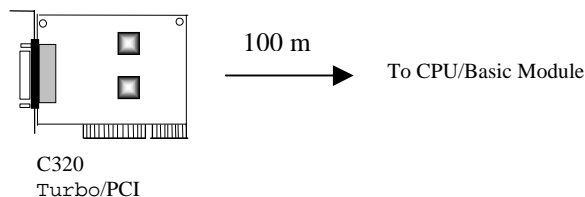

CPU Module and UART Module for Desktop Option

CPU Module (for Desktop option)

- ❖ 40 MHz TMS320C52 processor
- ❖ 16 KB ROM and 32 K Words RAM
- ❖ Diagnostic LEDs show full status of each serial port, including TxD, RxD, DTR, DSR, RTS, CTS, DCD
- ❖ Optional power adapter for use when the distance between Control Board and CPU Module is longer than 2 meters. In this case, a 10-signal-pin DB25 to DB25 cable must be used between Control Board and CPU Module.
- ❖ Power switch
- ❖ FCC Class A

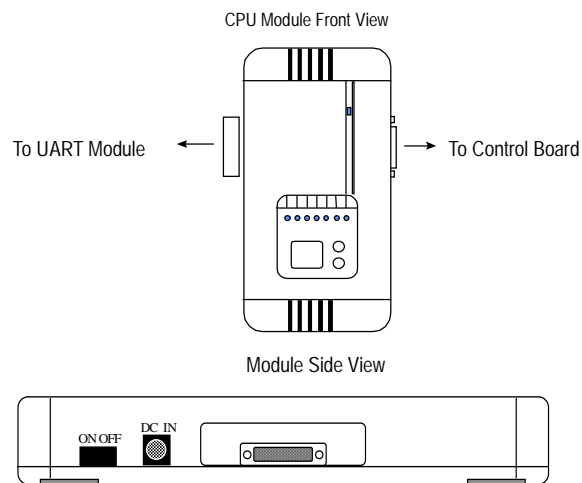

UART Module (for Desktop option)

- ❖ 8 RS-232/RS-422 serial ports
- ❖ TI1550C UART chip with 32 bytes FIFO (Tx+Rx) and on-chip hardware flow control
- ❖ Each UART chip drives one serial port (Max. 460.8 Kbps)
- ❖ Up to 4 (at least one) modules can be connected to one Control Board
- ❖ RS-232 (DB25 female/male connectors) : TxD, RxD, RTS, CTS, DTR, DSR, DCD, GND (Full modem control signals)
- ❖ RS-422 (DB25 female connectors) : TxD+/-, RxD+/-, CTS+/-, RTS+/-, GND
- ❖ Fixing Kit with 2 metal plates and 4 screws
- ❖ FCC Class A

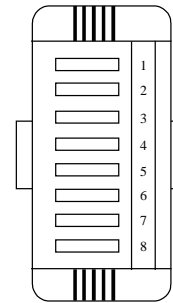

UART Module

Basic Module and Extensive Module for Rackmount Option

Basic Module (for Rackmount option)

- ❖ 8 or 16 serial ports
- ❖ 40MHz TMS320C52 processor
- ❖ 16KB ROM and 32K Words RAM
- ❖ Diagnostics LEDs show full status of each serial port, including TxD, RxD, DTR, DSR, RTS, CTS, DCD
- ❖ 16550C UART chip with 32 bytes FIFO (Tx+Rx) and on-chip hardware flow control
- ❖ Each UART chip drives one serial port (Max. 460.8K bps)
- ❖ Full modem control (RS-232 interface)
- ❖ RJ-45 connector for each serial port
- ❖ Optional power adapter for use when the distance between Control Board and Basic Module is longer than 2 meters. In this case, a 10-signal-pin DB25 to DB25 cable must be used between Control Board and Basic Module.
- ❖ Power switch

Basic Module (Front View)

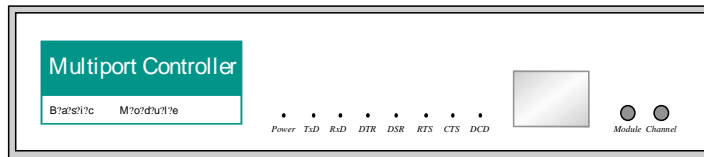

Basic Module (Rear View)

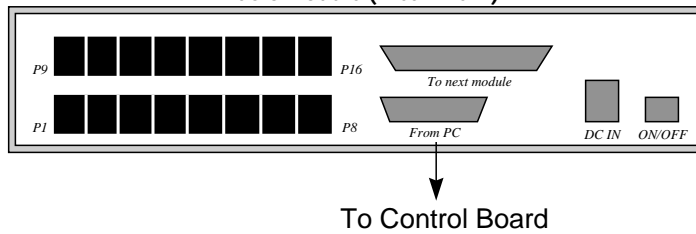

Extensive Module (for Rackmount option)

- ❖ 8 or 16 RS-232 serial ports
- ❖ 16550C UART chip with 32 bytes FIFO (Tx+Rx) and on-chip hardware flow control
- ❖ Each UART chip drives one serial port (Max. 460.8 Kbps)
- ❖ Full modem control (RS-232 interface)
- ❖ RJ-45 connector for each serial port

Extensive Module (Front View)

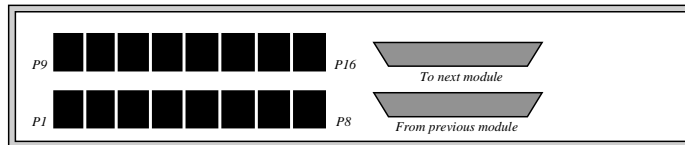

PCI

The 32-bit Intellio C320Turbo/PCI board complies with PCI Spec. 2.1. Hardware configuration for IRQ and Memory addresses is automatically assigned by PCI BIOS. Hence, it is a must to **have the board plugged first** before installing software driver.

Unlike ISA slots, different PCI slots in the same PC may have different bus numbers and device numbers with respect to PCI specifications. The same PCI board will have different system configurations if switched to a different PCI slot, which may be called **slot-sensitive** or **slot-dependent**. This may also apply to PCI slots in PC of different mother board, which may use **different device number set**. For example, some use 17, 18, 19, and 20 for identifying the respective PCI slot but some use 11, 12, 13 and 14.

Due to the **slot-dependency**, it is necessary to **re-configure the software driver** once the board is plugged in different PCI slots.

Up to four boards of Intellio C320Turbo/PCI are allowed in a system. When installing multiple boards, **please do keep in mind the order you plug the boards** for distinguishing the boards installed.

Dual-Ported RAM

There is 512 KB of dual-ported DRAM on the Intellio C320Turbo/PCI Control Board, which is used as a data buffer and memory map device for the motherboard. it is called “dual-ported” because it is accessed by both motherboard CPU and the Intellio C320Turbo/PCI Control Board’s on-board CPU. Generally speaking, the memory access time is much faster than normal I/O access.

All messages and data are transferred through this 512 KB dual-ported memory. The buffer area appears as normal 16-bit memory to the PC AT I/O channel.

Every Intellio C320Turbo/PCI Control Board only occupies 16 KB of memory space (window) from the system point of view. Memory base addresses range from 1 M to 4 GB.

16550C in UART/Basic/Extensive Modules

The 16550C is an advanced asynchronous controller capable of on-chip hardware flow control and highest speed up to 921.6 Kbps. Inside UART/Basic/Extensive Module, each 16550C chip controls one port.

Problem Report Form

Intellio C320Turbo/PCI

Customer name:	
Company:	
Tel:	Fax:
Email:	Date:

1. **Moxa Product:** C320Turbo/PCI **Serial Number:** _____

2. **Moxa Driver Version:** _____

3. **Moxa hardware settings:** Memory Bank Address: _____ IRQ: _____

4. **Operating System:** Windows NT 3.51 Windows NT 4.0
 Windows 95 Windows 98
 SCO UNIX 3.2.4 SCO OpenServer Release 5 XENIX
 (SCO) UnixWare ver __.____ SVR4.2 UNIX
 Linux 2.____ Others

5. **PC Host:** Make _____ Model _____

6. **CPU:** Speed _____MHz Make _____ Model _____

7. **BIOS:** Make _____ Version _____

8. **PCI IRQ Configuration in BIOS:**

Slot no.	1	2	3	4
IRQ no				

9. **Problem Description:** Please describe the symptom as clear as possible including the error message you see. We may have to follow your description to reproduce the symptom.

- Board not found. Board found, but can't transfer data.
 Can transfer data, but lose data. Can transfer data but with garbled data.
 Others. Detailed error message description is recommended:

Return Procedure

For product repair, exchange or refund, you must:

- ❖ Provide evidence of original purchase
- ❖ Fill out the Problem Report Form (PRF) as detailed as possible for shorter product repair time.
- ❖ Obtain a Return Merchandise Authorization (RMA) number from the sales representative or dealer
- ❖ Carefully pack the product in anti-static package, and send it, pre-paid, to the dealer. The RMA number should show on the outside of the package, and include a description of the problem along with the return address and telephone number of a technical contact.